

## PolarHV™ Power MOSFET

N-Channel Enhancement Mode  
Avalanche Rated

**IXTH 36N50P**  
**IXTQ 36N50P**  
**IXTT 36N50P**  
**IXTV 36N50P**  
**IXTV 36N50PS**

$V_{DSS} = 500 \text{ V}$   
 $I_{D25} = 36 \text{ A}$   
 $R_{DS(on)} \leq 170 \text{ m}\Omega$

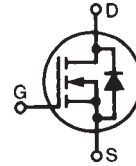

| Symbol     | Test Conditions   | Maximum Ratings |                  |
|------------|---|-----------------|------------------|
| $V_{DSS}$  | $T_J = 25^\circ\text{C}$ to $150^\circ\text{C}$   | 500             | V                |
| $V_{DGR}$  | $T_J = 25^\circ\text{C}$ to $150^\circ\text{C}$ ; $R_{GS} = 1 \text{ M}\Omega$  | 500             | V                |
| $V_{GS}$   | Continuous  | $\pm 30$        | V                |
| $V_{GSM}$  | Transient   | $\pm 40$        | V                |
| $I_{D25}$  | $T_C = 25^\circ\text{C}$  | 36              | A                |
| $I_{DM}$   | $T_C = 25^\circ\text{C}$ , pulse width limited by $T_{JM}$  | 108             | A                |
| $I_{AR}$   | $T_C = 25^\circ\text{C}$  | 36              | A                |
| $E_{AR}$   | $T_C = 25^\circ\text{C}$  | 50              | mJ               |
| $E_{AS}$   | $T_C = 25^\circ\text{C}$  | 1.5             | J                |
| $dv/dt$    | $I_S \leq I_{DM}$ , $di/dt \leq 100 \text{ A}/\mu\text{s}$ , $V_{DD} \leq V_{DSS}$ ,<br>$T_J \leq 150^\circ\text{C}$ , $R_G = 3 \Omega$ | 10              | V/ns             |
| $P_D$      | $T_C = 25^\circ\text{C}$  | 540             | W                |
| $T_J$      |   | -55 ... +150    | $^\circ\text{C}$ |
| $T_{JM}$   |   | 150             | $^\circ\text{C}$ |
| $T_{stg}$  |   | -55 ... +150    | $^\circ\text{C}$ |
| $T_L$      | 1.6 mm (0.062 in.) from case for 10 s   | 300             | $^\circ\text{C}$ |
| $T_{SOLD}$ | Plastic body for 10 s   | 260             | $^\circ\text{C}$ |
| $M_d$      | Mounting torque(TO-247)   | 1.13/10         | Nm/lb.in.        |
| $F_c$      | Mounting force (PLUS220)  | 20..120/4.5..15 | N/lb             |
| Weight     | TO-247  | 6               | g                |
|            | TO-268  | 5               | g                |
|            | PLUS220   | 2               | g                |
|            | TO-3P   | 5.5             | g                |

TO-3P (IXTQ)

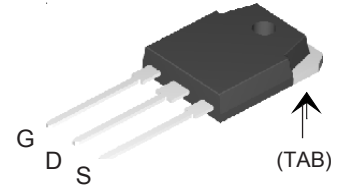

TO-247 (IXTH)

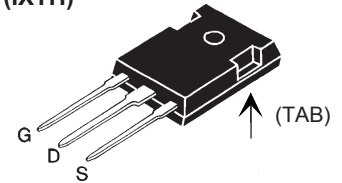

TO-268 (IXTT)

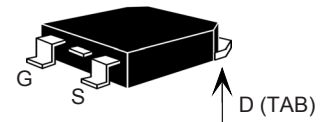

PLUS220 (IXTV)

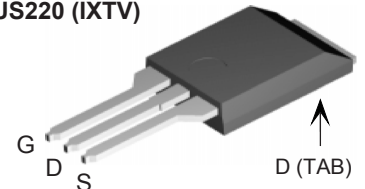

PLUS220 SMD(IXTV..S)

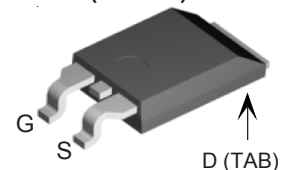

G = Gate  
S = Source  
D = Drain  
TAB = Drain

| Symbol       | Test Conditions<br>( $T_J = 25^\circ\text{C}$ unless otherwise specified)  | Characteristic Values |      |                      |
|--------------|--|-----------------------|------|----------------------|
|              |  | Min.                  | Typ. | Max.                 |
| $V_{DSS}$    | $V_{GS} = 0 \text{ V}$ , $I_D = 250 \mu\text{A}$   | 500                   |      | V                    |
| $V_{GS(th)}$ | $V_{DS} = V_{GS}$ , $I_D = 250 \mu\text{A}$  | 3.0                   |      | 5.0 V                |
| $I_{GSS}$    | $V_{GS} = \pm 30 \text{ V}_{DC}$ , $V_{DS} = 0$  |                       |      | $\pm 100 \text{ nA}$ |
| $I_{DSS}$    | $V_{DS} = V_{DSS}$<br>$V_{GS} = 0 \text{ V}$<br>$T_J = 125^\circ\text{C}$  |                       |      | 25 $\mu\text{A}$     |
|              |  |                       |      | 250 $\mu\text{A}$    |
| $R_{DS(on)}$ | $V_{GS} = 10 \text{ V}$ , $I_D = 0.5 I_{D25}$<br>Pulse test, $t \leq 300 \mu\text{s}$ , duty cycle $d \leq 2 \%$ |                       |      | 170 $\text{m}\Omega$ |

### Features

- International standard packages
- Unclamped Inductive Switching (UIS) rated
- Low package inductance
- easy to drive and to protect

| Symbol       | Test Conditions   | Characteristic Values<br>( $T_J = 25^\circ\text{C}$ unless otherwise specified) |      |                         |
|--------------|---|---|------|-------------------------|
|              |   | Min.  | Typ. | Max.                    |
| $g_{fs}$     | $V_{DS} = 20\text{ V}; I_D = 0.5 I_{D25}$ , pulse test                                      | 23  | 36   | S                       |
| $C_{iss}$    | $V_{GS} = 0\text{ V}, V_{DS} = 25\text{ V}, f = 1\text{ MHz}$                               |   | 5500 | pF                      |
| $C_{oss}$    |   |   | 510  | pF                      |
| $C_{rss}$    |   |   | 40   | pF                      |
| $t_{d(on)}$  | $V_{GS} = 10\text{ V}, V_{DS} = 0.5 V_{DSS}, I_D = I_{D25}$<br>$R_G = 3\ \Omega$ (External) |   | 25   | ns                      |
| $t_r$        |   |   | 27   | ns                      |
| $t_{d(off)}$ |   |   | 75   | ns                      |
| $t_f$        |   |   | 21   | ns                      |
| $Q_{g(on)}$  | $V_{GS} = 10\text{ V}, V_{DS} = 0.5 V_{DSS}, I_D = 0.5 I_{D25}$                             |   | 85   | nC                      |
| $Q_{gs}$     |   |   | 30   | nC                      |
| $Q_{gd}$     |   |   | 31   | nC                      |
| $R_{thJC}$   |   |   |      | 0.23 $^\circ\text{C/W}$ |
| $R_{thCS}$   | (TO-247 and TO-3P)<br>(PLUS220)   |   | 0.21 | $^\circ\text{C/W}$      |

**Source-Drain Diode**

| Symbol   | Test Conditions   | Characteristic Values<br>( $T_J = 25^\circ\text{C}$ unless otherwise specified) |      |       |
|----------|---|---|------|-------|
|          |   | Min.  | Typ. | Max.  |
| $I_S$    | $V_{GS} = 0\text{ V}$   |   |      | 36 A  |
| $I_{SM}$ | Repetitive  |   |      | 108 A |
| $V_{SD}$ | $I_F = I_S, V_{GS} = 0\text{ V}$ ,<br>Pulse test, $t \leq 300\ \mu\text{s}$ , duty cycle $d \leq 2\%$ |   |      | 1.5 V |
| $t_{rr}$ | $I_F = 25\text{ A}, -di/dt = 100\text{ A}/\mu\text{s}$<br>$V_R = 100\text{ V}, V_{GS} = 0\text{ V}$   |   | 400  | ns    |

**Characteristic Curves**

**Fig. 1. Output Characteristics  
@ 25°C**

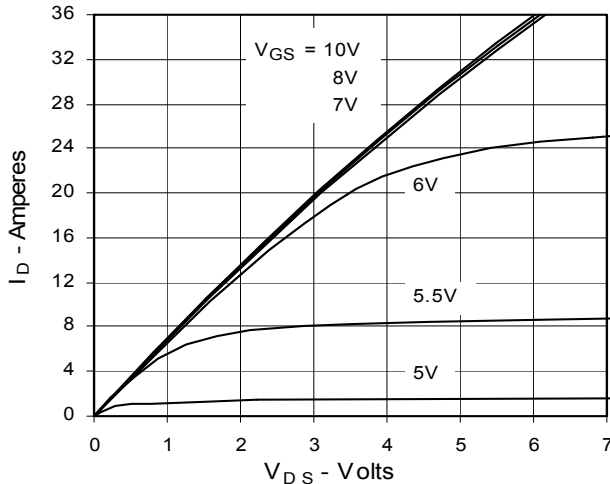

**Fig. 2. Extended Output Characteristics  
@ 25°C**

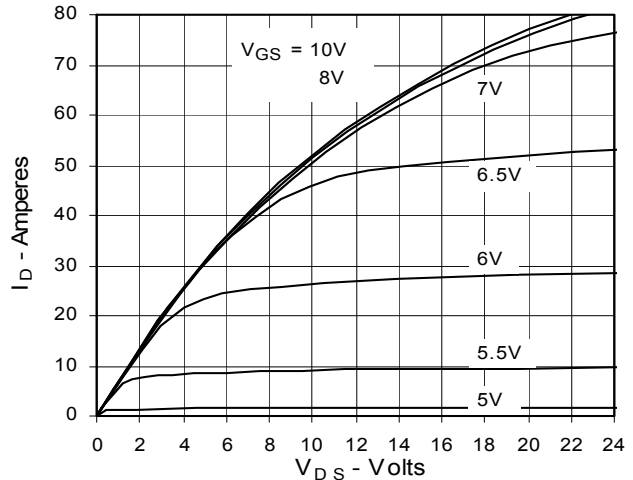

IXYS reserves the right to change limits, test conditions, and dimensions.

IXYS MOSFETs and IGBTs are covered by 4,835,592 4,931,844 5,049,961 5,237,481 6,162,665 6,404,065 B1 6,683,344 6,727,585  
one or more of the following U.S. patents: 4,850,072 5,017,508 5,063,307 5,381,025 6,259,123 B1 6,534,343 6,710,405B2 6,759,692  
4,881,106 5,034,796 5,187,117 5,486,715 6,306,728 B1 6,583,505 6,710,463 6,771,478 B2

**Fig. 3. Output Characteristics @ 125°C**

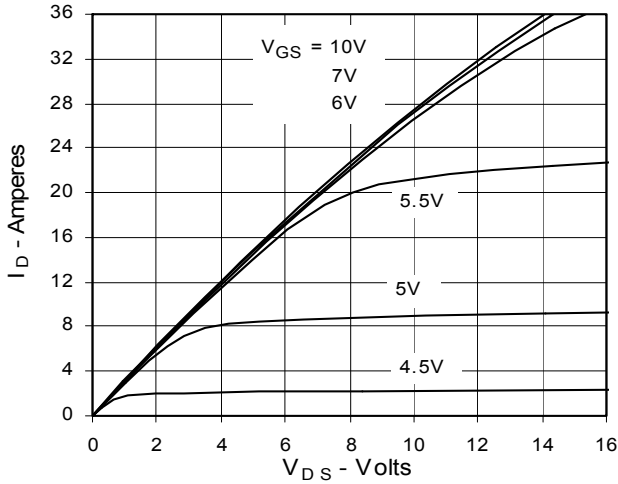

**Fig. 4.  $R_{DS(on)}$  Normalized to  $I_D = 18\text{A}$  Value vs. Junction Temperature**

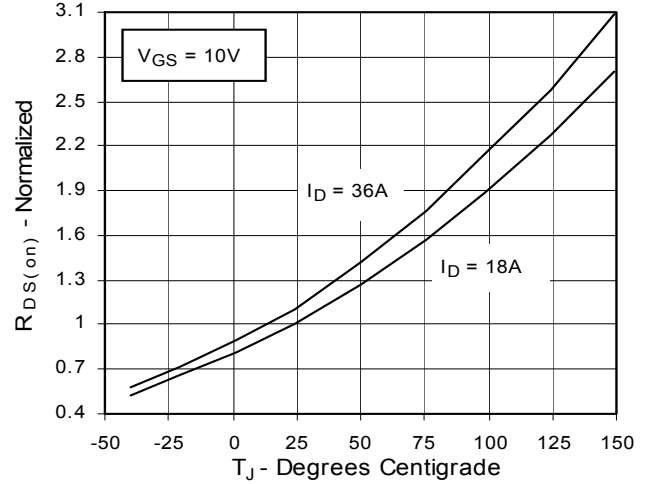

**Fig. 5.  $R_{DS(on)}$  Normalized to  $I_D = 18\text{A}$  Value vs. Drain Current**

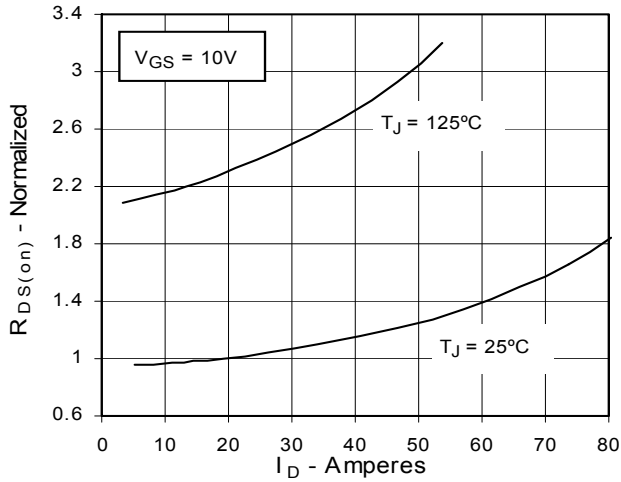

**Fig. 6. Drain Current vs. Case Temperature**

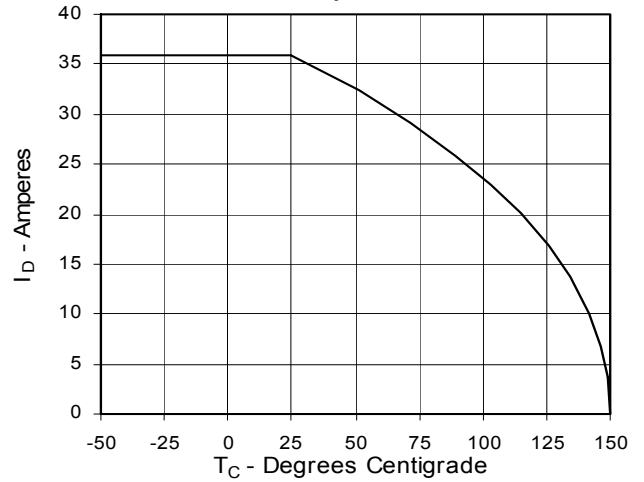

**Fig. 7. Input Admittance**

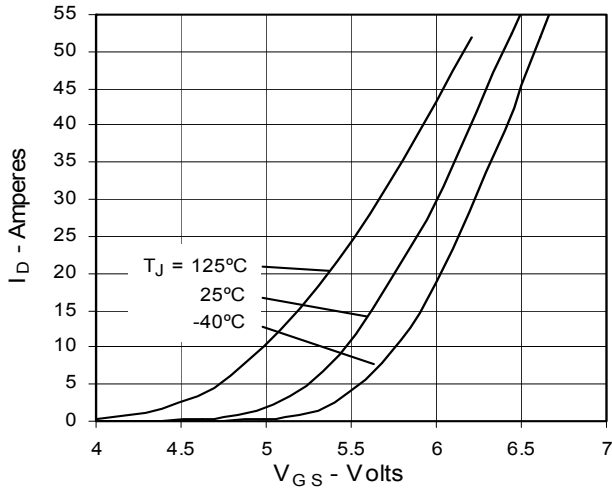

**Fig. 8. Transconductance**

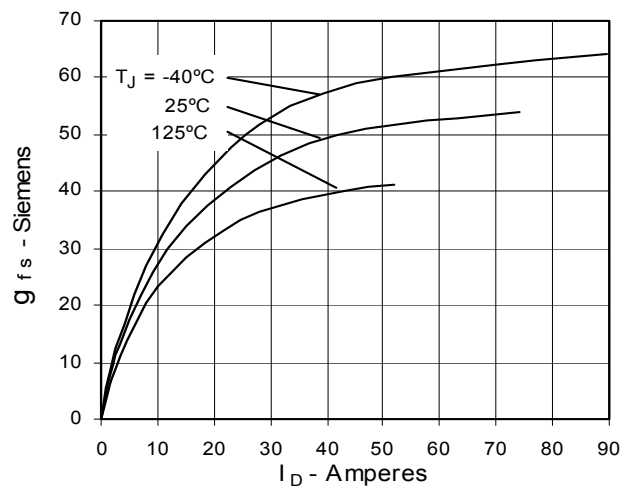

**Fig. 9. Source Current vs. Source-To-Drain Voltage**

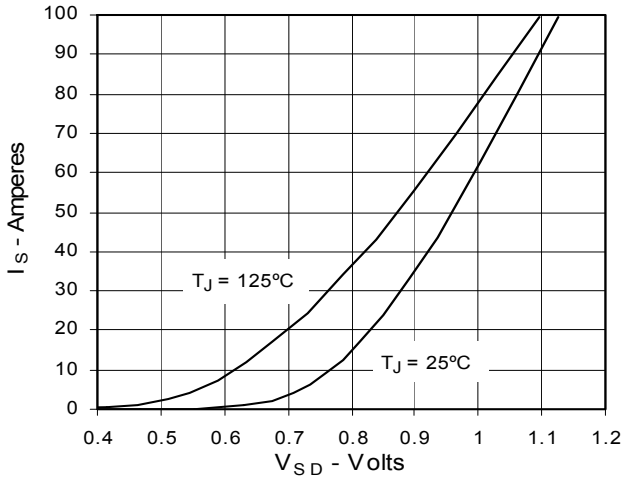

**Fig. 10. Gate Charge**

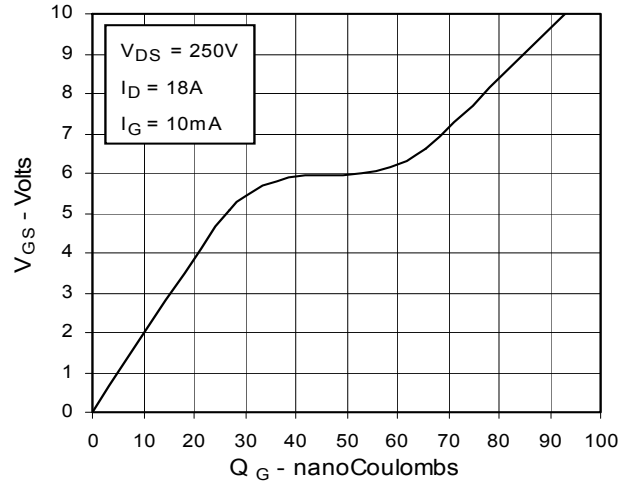

**Fig. 11. Capacitance**

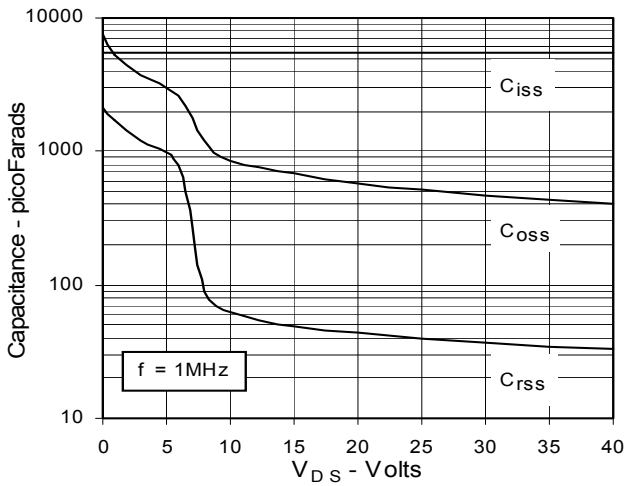

**Fig. 12. Forward-Bias Safe Operating Area**

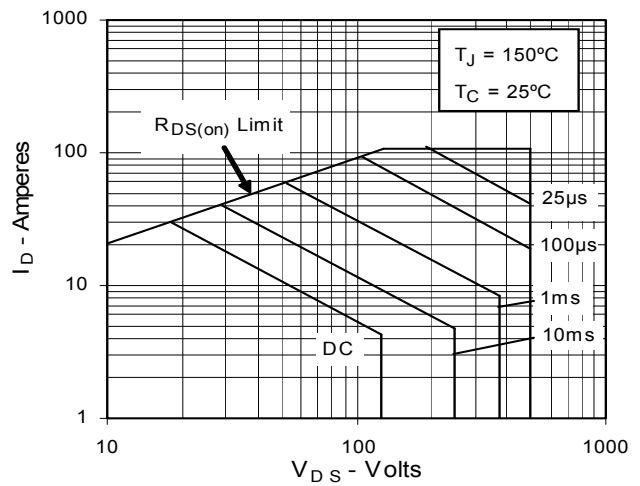

**Fig. 13. Maximum Transient Thermal Resistance**

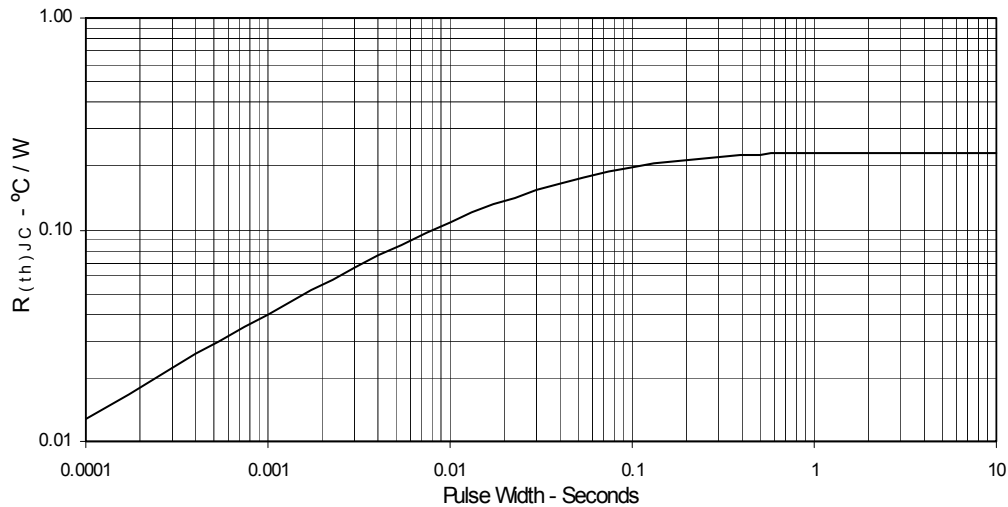

**TO-247 AD (IXTH) Outline**

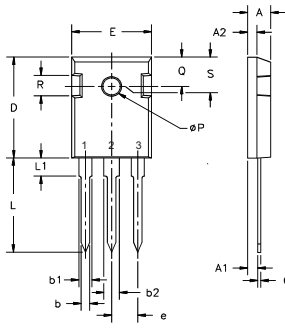

- Terminals:  
1 - Gate  
2 - Drain  
3 - Source

| Dim.           | Millimeter |       | Inches |       |
|----------------|------------|-------|--------|-------|
|                | Min.       | Max.  | Min.   | Max.  |
| A              | 4.7        | 5.3   | .185   | .209  |
| A <sub>1</sub> | 2.2        | 2.54  | .087   | .102  |
| A <sub>2</sub> | 2.2        | 2.6   | .059   | .098  |
| b              | 1.0        | 1.4   | .040   | .055  |
| b <sub>1</sub> | 1.65       | 2.13  | .065   | .084  |
| b <sub>2</sub> | 2.87       | 3.12  | .113   | .123  |
| C              | .4         | .8    | .016   | .031  |
| D              | 20.80      | 21.46 | .819   | .845  |
| E              | 15.75      | 16.26 | .610   | .640  |
| e              | 5.20       | 5.72  | 0.205  | 0.225 |
| L              | 19.81      | 20.32 | .780   | .800  |
| L <sub>1</sub> |            | 4.50  |        | .177  |
| ØP             | 3.55       | 3.65  | .140   | .144  |
| Q              | 5.89       | 6.40  | 0.232  | 0.252 |
| R              | 4.32       | 5.49  | .170   | .216  |
| S              | 6.15       | BSC   | .242   | BSC   |

**TO-3P (IXTQ) Outline**

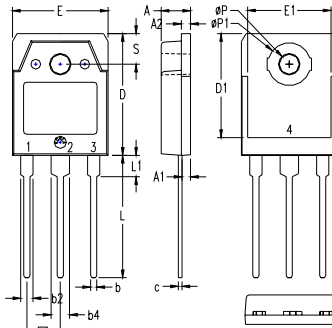

- 1 - GATE  
2 - DRAIN (COLLECTOR)  
3 - SOURCE (EMITTER)  
4 - DRAIN (COLLECTOR)

| SYM             | INCHES   |      | MILLIMETERS |       |
|-----------------|----------|------|-------------|-------|
|                 | MIN      | MAX  | MIN         | MAX   |
| A               | .185     | .193 | 4.70        | 4.90  |
| A <sub>1</sub>  | .051     | .059 | 1.30        | 1.50  |
| A <sub>2</sub>  | .057     | .065 | 1.45        | 1.65  |
| b               | .035     | .045 | 0.90        | 1.15  |
| b <sub>2</sub>  | .075     | .087 | 1.90        | 2.20  |
| b <sub>4</sub>  | .114     | .126 | 2.90        | 3.20  |
| c               | .022     | .031 | 0.55        | 0.80  |
| D               | .780     | .799 | 19.80       | 20.30 |
| D <sub>1</sub>  | .665     | .677 | 16.90       | 17.20 |
| E               | .610     | .622 | 15.50       | 15.80 |
| E <sub>1</sub>  | .531     | .539 | 13.50       | 13.70 |
| e               | .215 BSC |      | 5.45 BSC    |       |
| L               | .779     | .795 | 19.80       | 20.20 |
| L <sub>1</sub>  | .134     | .142 | 3.40        | 3.60  |
| ØP <sub>1</sub> | .126     | .134 | 3.20        | 3.40  |
| S               | .272     | .280 | 6.90        | 7.10  |
| S               | .193     | .201 | 4.90        | 5.10  |

**TO-268 (IXTT) Outline**

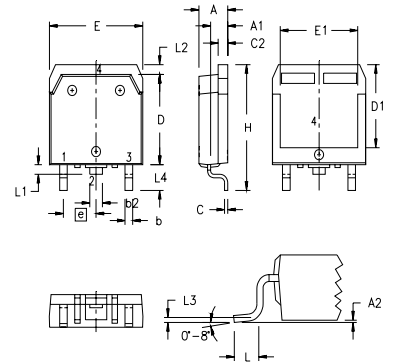

| SYM            | INCHES   |      | MILLIMETERS |       |
|----------------|----------|------|-------------|-------|
|                | MIN      | MAX  | MIN         | MAX   |
| A              | .193     | .201 | 4.90        | 5.10  |
| A <sub>1</sub> | .106     | .114 | 2.70        | 2.90  |
| A <sub>2</sub> | .001     | .010 | 0.02        | 0.25  |
| b              | .045     | .057 | 1.15        | 1.45  |
| b <sub>2</sub> | .075     | .083 | 1.90        | 2.10  |
| C              | .016     | .026 | 0.40        | 0.65  |
| C <sub>2</sub> | .057     | .063 | 1.45        | 1.60  |
| D              | .543     | .551 | 13.80       | 14.00 |
| D <sub>1</sub> | .488     | .500 | 12.40       | 12.70 |
| E              | .624     | .632 | 15.85       | 16.05 |
| E <sub>1</sub> | .524     | .535 | 13.30       | 13.60 |
| e              | .215 BSC |      | 5.45 BSC    |       |
| H              | .736     | .752 | 18.70       | 19.10 |
| L              | .094     | .106 | 2.40        | 2.70  |
| L <sub>1</sub> | .047     | .055 | 1.20        | 1.40  |
| L <sub>2</sub> | .039     | .045 | 1.00        | 1.15  |
| L <sub>3</sub> | .010 BSC |      | 0.25 BSC    |       |
| L <sub>4</sub> | .150     | .161 | 3.80        | 4.10  |

**PLUS220 (IXTV) Outline**

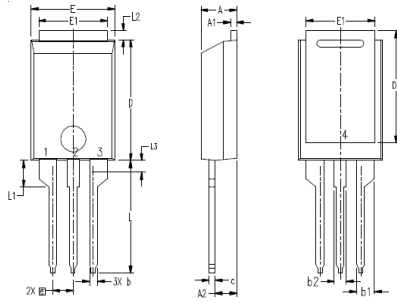

1. GATE  
2. DRAIN (COLLECTOR)  
3. SOURCE (EMITTER)  
4. DRAIN (COLLECTOR)

| SYM            | INCHES   |      | MILLIMETER |       |
|----------------|----------|------|------------|-------|
|                | MIN      | MAX  | MIN        | MAX   |
| A              | .169     | .185 | 4.30       | 4.70  |
| A <sub>1</sub> | .028     | .035 | 0.70       | 0.90  |
| A <sub>2</sub> | .098     | .118 | 2.50       | 3.00  |
| b              | .035     | .047 | 0.90       | 1.20  |
| b <sub>1</sub> | .080     | .095 | 2.03       | 2.41  |
| b <sub>2</sub> | .054     | .064 | 1.37       | 1.63  |
| c              | .028     | .035 | 0.70       | 0.90  |
| D              | .551     | .591 | 14.00      | 15.00 |
| D <sub>1</sub> | .512     | .539 | 13.00      | 13.70 |
| E              | .394     | .433 | 10.00      | 11.00 |
| E <sub>1</sub> | .331     | .346 | 8.40       | 8.80  |
| e              | .100 BSC |      | 2.54 BSC   |       |
| L              | .512     | .551 | 13.00      | 14.00 |
| L <sub>1</sub> | .118     | .138 | 3.00       | 3.50  |
| L <sub>2</sub> | .035     | .051 | 0.90       | 1.30  |
| L <sub>3</sub> | .047     | .059 | 1.20       | 1.50  |

**PLUS220SMD (IXTV\_S) Outline**

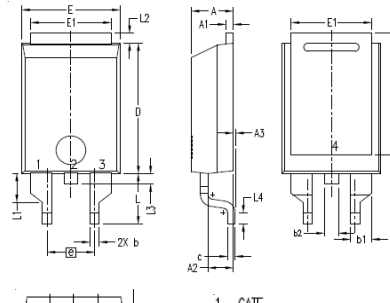

1. GATE  
2. DRAIN (COLLECTOR)  
3. SOURCE (EMITTER)  
4. DRAIN (COLLECTOR)

| SYM            | INCHES   |      | MILLIMETER |       |
|----------------|----------|------|------------|-------|
|                | MIN      | MAX  | MIN        | MAX   |
| A              | .169     | .185 | 4.30       | 4.70  |
| A <sub>1</sub> | .028     | .035 | 0.70       | 0.90  |
| A <sub>2</sub> | .098     | .118 | 2.50       | 3.00  |
| A <sub>3</sub> | .000     | .010 | 0.00       | 0.25  |
| b              | .035     | .047 | 0.90       | 1.20  |
| b <sub>1</sub> | .080     | .095 | 2.03       | 2.41  |
| b <sub>2</sub> | .054     | .064 | 1.37       | 1.63  |
| c              | .028     | .035 | 0.70       | 0.90  |
| D              | .551     | .591 | 14.00      | 15.00 |
| D <sub>1</sub> | .512     | .539 | 13.00      | 13.70 |
| E              | .394     | .433 | 10.00      | 11.00 |
| E <sub>1</sub> | .331     | .346 | 8.40       | 8.80  |
| e              | .200 BSC |      | 5.08 BSC   |       |
| L              | .209     | .228 | 5.30       | 5.80  |
| L <sub>1</sub> | .118     | .138 | 3.00       | 3.50  |
| L <sub>2</sub> | .035     | .051 | 0.90       | 1.30  |
| L <sub>3</sub> | .047     | .059 | 1.20       | 1.50  |
| L <sub>4</sub> | .039     | .059 | 1.00       | 1.50  |

# Mouser Electronics

Authorized Distributor

Click to View Pricing, Inventory, Delivery & Lifecycle Information:

[IXYS:](#)

[IXTH36N50P](#) [IXTQ36N50P](#) [IXTT36N50P](#)