



PIC16(L)F170X/171X

Cost Effective 8-Bit Intelligent Analog Flash Microcontrollers

Description:

PIC16F(L)170X/171X microcontrollers combine Intelligent Analog integration with low cost and extreme low power (XLP) to suit a variety of general purpose applications. These 14 to 44-pin devices deliver on-chip Op Amps, Core Independent Peripherals (CLC, NCO and COG), Peripheral Pin Select and Zero-Cross Detect, providing for increased design flexibility.

Core Features:

- C Compiler Optimized RISC Architecture
- Only 49 Instructions
- Operating Speed:
 - 0-32 MHz clock input
 - 125 ns minimum instruction cycle
- Interrupt Capability
- 16-Level Deep Hardware Stack
- Up to Four 8-bit Timers
- One 16-bit Timer
- Power-on Reset (POR)
- Power-up Timer (PWRT)
- Low-Power Brown-Out Reset (LPBOR)
- Programmable Watchdog Timer (WDT) up to 256s
- Programmable Code Protection

Memory:

- Up to 16 Kwords Flash Program Memory
- Up to 2048 Bytes Data SRAM Memory
- Direct, Indirect and Relative Addressing modes

Operating Characteristics:

- Operating Voltage Range:
 - 1.8V to 3.6V (PIC16LF170X/171X)
 - 2.3V to 5.5V (PIC16F170X/171X)
- Temperature Range:
 - Industrial: -40°C to 85°C
 - Extended: -40°C to 125°C

eXtreme Low-Power (XLP) Features:

- Sleep mode: 50 nA @ 1.8V, typical
- Watchdog Timer: 500 nA @ 1.8V, typical
- Secondary Oscillator: 500 nA @ 32 kHz
- Operating Current:
 - 8 uA @ 32 kHz, 1.8V, typical
 - 32 uA/MHz @ 1.8V, typical

Digital Peripherals:

- Configurable Logic Cell (CLC):
 - Integrated combinational and sequential logic
- Complementary Output Generator (COG):
 - Rising/falling edge dead-band control/blanking
- Numerically Controlled Oscillator (NCO):
 - Generates true linear frequency control and increased frequency resolution
 - Input Clock: 0Hz < FNCO < 32 MHz
 - Resolution: FNCO/220
- Capture/Compare/PWM (CCP) module
- PWM: Two 10-bit Pulse-Width Modulators
- Serial Communications:
 - SPI, I²C™, RS-232, RS-485, LIN compatible
 - Auto-Baud Detect, auto-wake-up on start
- Up to 35 I/O Pins and One Input Pin:
 - Individually programmable pull-ups
 - Slew rate control
 - Interrupt-on-change with edge-select
- Peripheral Pin Select (PPS):
 - Enables pin mapping of digital I/O

Intelligent Analog Peripherals:

- Operational Amplifiers:
 - Two configurable rail-to-rail op amps
 - Selectable internal and external channels
 - 2 MHz gain bandwidth product
- High-Speed Comparators:
 - Up to two comparators
 - 50 ns response time
 - Rail-to-rail inputs
- 10-Bit Analog-to-Digital Converter (ADC):
 - Up to 28 external channels
 - Conversion available during Sleep
 - Temperature indicator
- Zero-Cross Detector (ZCD):
 - Detect when AC signal on pin crosses ground
- 8-Bit Digital-to-Analog Converter (DAC):
 - Output available externally
 - Internal connections to comparators, op amps, Fixed Voltage Reference (FVR) and ADC
- Internal Voltage Reference module

PIC16(L)F170X/171X

Clocking Structure:

- 16 MHz Internal Oscillator Block:
 - $\pm 1\%$ at calibration
 - Selectable frequency range from 0 to 32 MHz
- 31 kHz Low-Power Internal Oscillator
- External Oscillator Block with:
 - Three crystal/resonator modes up to 20 MHz
 - Two external clock modes up to 32 MHz
- Fail-Safe Clock Monitor
- Two-Speed Oscillator Start-up
- Oscillator Start-up Timer (OST)

Programming/Debug Features:

- In-Circuit Debug Integrated On-Chip
- Emulation Header for Advanced Debug:
 - Provides trace, background debug and up to 32 hardware break points
- In-Circuit Serial Programming™ (ICSP™) via Two Pins

PIC16(L)F170X/171X FAMILY TYPES

Device	Program Memory Flash (words)	Data SRAM (bytes)	I/O Pins	8-bit/16-bit Timers	High-Speed Comparators	Op Amp	10-bit ADC (ch)	5-/8-bit DAC	Zero Cross	CCP/PWM	COG	EUSART	I ² C™/SPI	CLC	NCO	Debug ⁽¹⁾
PIC16(L)F1703	2k	256	12	2/1	0	2	8	0/0	1	2/0	0	0	1	0	0	I/E
PIC16(L)F1704	4k	512	12	4/1	2	2	8	0/1	1	2/2	1	1	1	3	0	I/E
PIC16(L)F1705	8k	1024	12	4/1	2	2	8	0/1	1	2/2	1	1	1	3	0	I/E
PIC16(L)F1707	2k	256	18	2/1	0	2	8	0/0	1	2/0	0	0	1	0	0	I/E
PIC16(L)F1708	4k	512	18	4/1	2	2	12	0/1	1	2/2	1	1	1	3	0	I/E
PIC16(L)F1709	8k	1024	18	4/1	2	2	12	0/1	1	2/2	1	1	1	3	0	I/E
PIC16(L)F1713	4k	512	25	4/1	2	2	17	1/1	1	2/2	1	1	1	4	1	I/E
PIC16(L)F1716	8k	1024	25	4/1	2	2	17	1/1	1	2/2	1	1	1	4	1	I/E
PIC16(L)F1717	8k	1024	36	4/1	2	2	28	1/1	1	2/2	1	1	1	4	1	I/E
PIC16(L)F1718	16k	2048	25	4/1	2	2	17	1/1	1	2/2	1	1	1	4	1	I/E
PIC16(L)F1719	16k	2048	36	4/1	2	2	28	1/1	1	2/2	1	1	1	4	1	I/E

Note 1: I – Debugging integrated on chip; H – Debugging via ICD header; E – Debugging via Emulation header.

PACKAGES

Device	PDIP	TSSOP	QFN (4x4x0.9)	SOIC	SSOP	SPDIP	QFN (6x6x0.9)	UQFN (4x4x0.5)	TQFP	UQFN (5x5x0.5)
PIC16F1703	x	x	x	x						
PIC16F1704	x	x	x	x						
PIC16F1705	x	x	x	x						
PIC16F1707	x		x	x	x					
PIC16F1708	x		x	x	x					
PIC16F1709	x		x	x	x					
PIC16F1713				x	x	x	x	x		
PIC16F1716				x	x	x	x	x		
PIC16F1717	x								x	x
PIC16F1718				x	x	x	x	x		
PIC16F1719	x								x	x

PIC16(L)F170X/171X

PIN DIAGRAM – 14-PIN PDIP, SOIC, SSOP

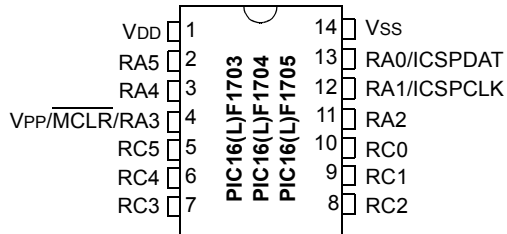

Note: See [Table 1](#) and [Table 2](#) for the pin allocation tables.

PIN DIAGRAM – 16-PIN QFN

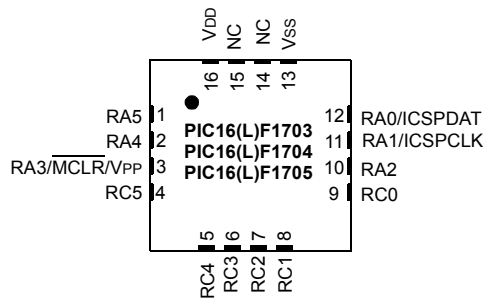

Note: See [Table 1](#) and [Table 2](#) or the pin allocation tables.

PIC16(L)F170X/171X

PIN DIAGRAM – 20-PIN PDIP, SOIC, SSOP

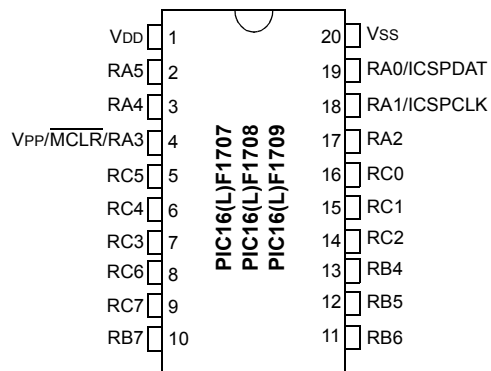

Note: See [Table 3](#) and [Table 4](#) for the pin allocation tables.

PIN DIAGRAM – 20-PIN QFN

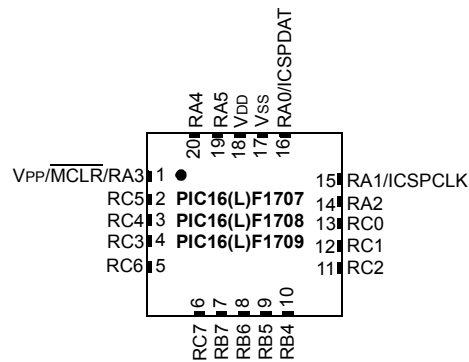

Note: See [Table 3](#) and [Table 4](#) for the pin allocation tables.

PIC16(L)F170X/171X

PIN DIAGRAM – 28-PIN PDIP, SOIC, SSOP

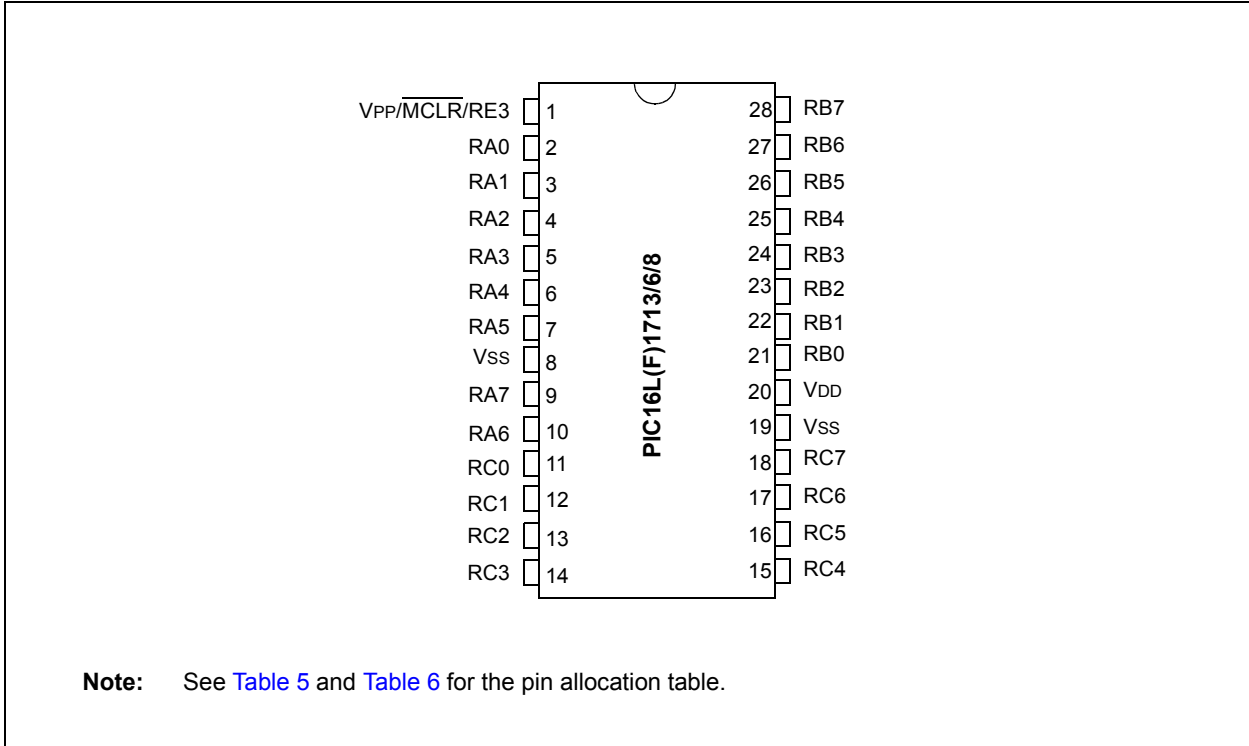

PIN DIAGRAM – 28-PIN (U)QFN

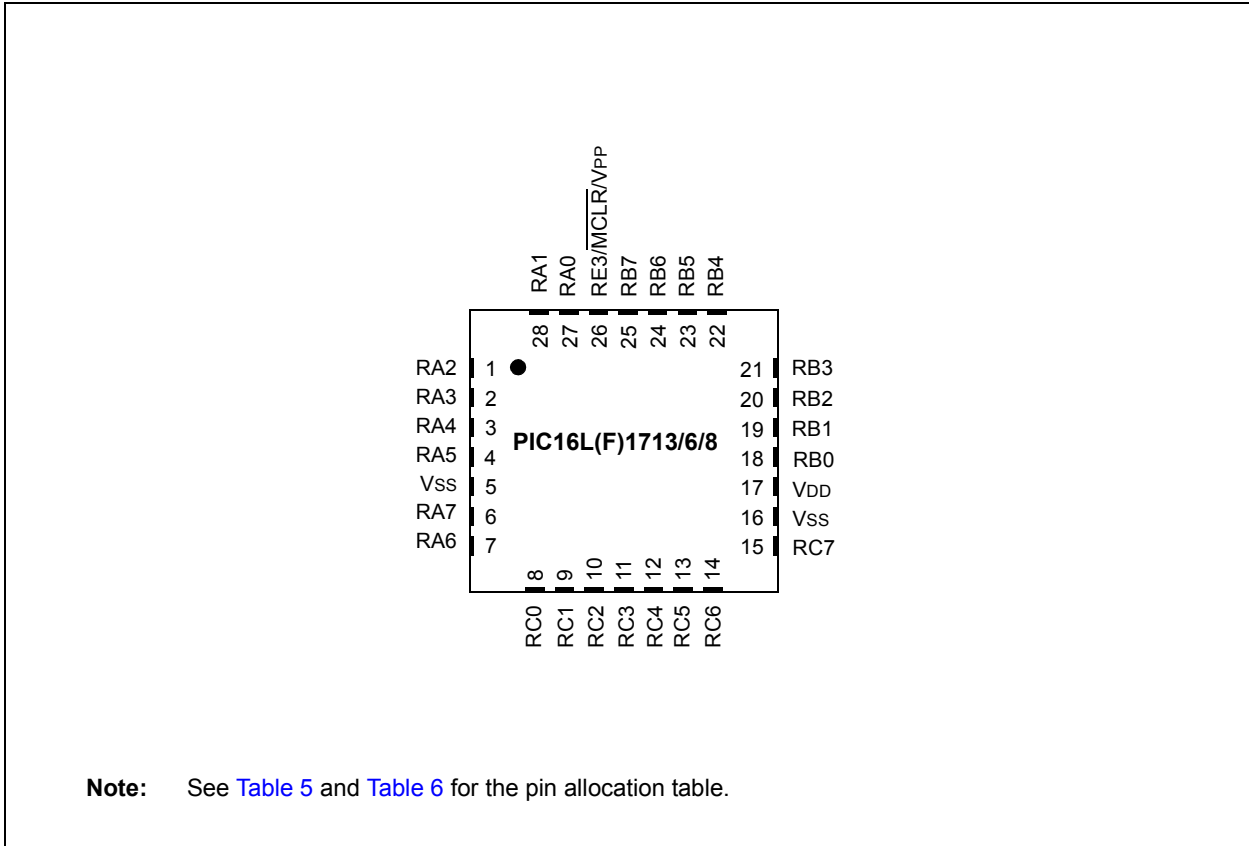

PIC16(L)F170X/171X

PIN DIAGRAM – 40-PIN PDIP

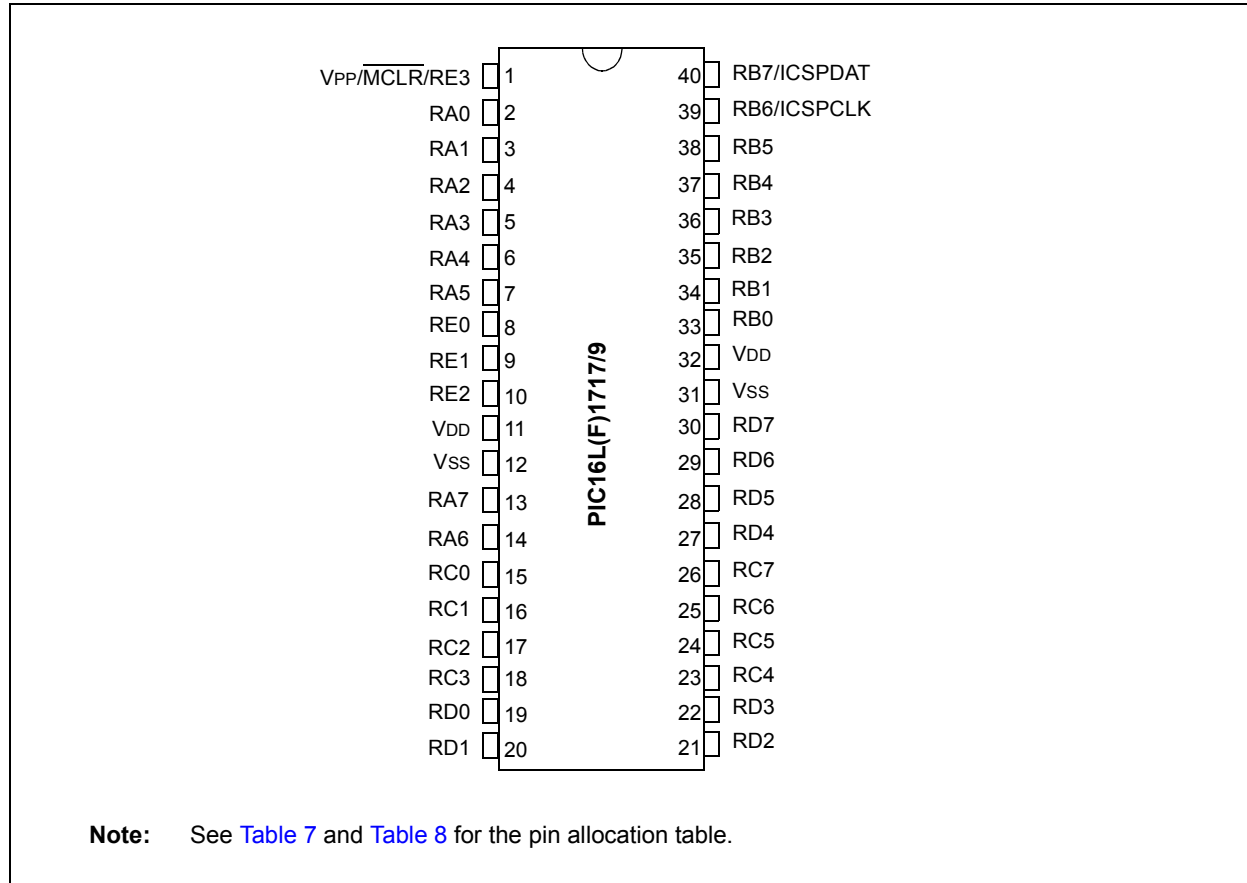

PIC16(L)F170X/171X

PIN DIAGRAM – 44-PIN TQFP (10x10)

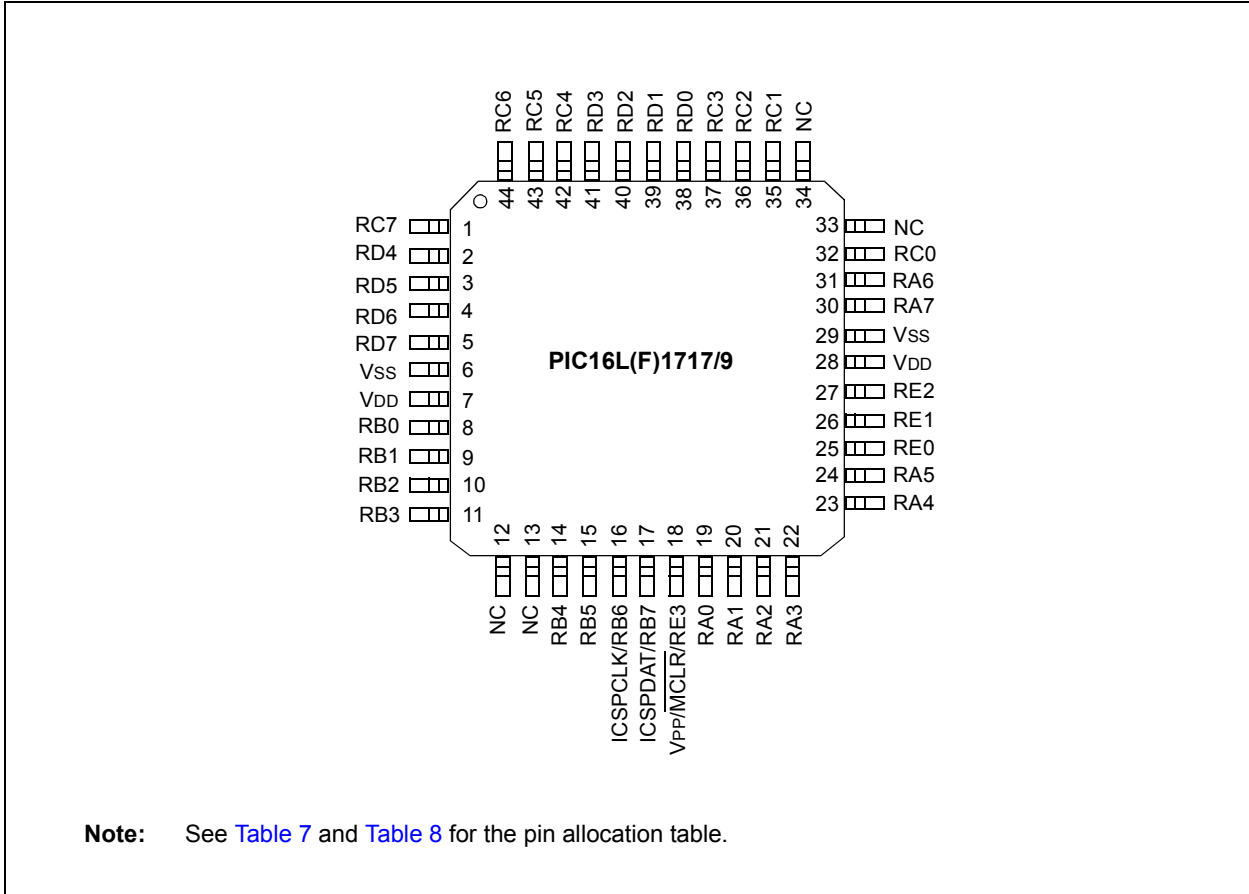

PIN DIAGRAM – 40-PIN UQFN (5x5)

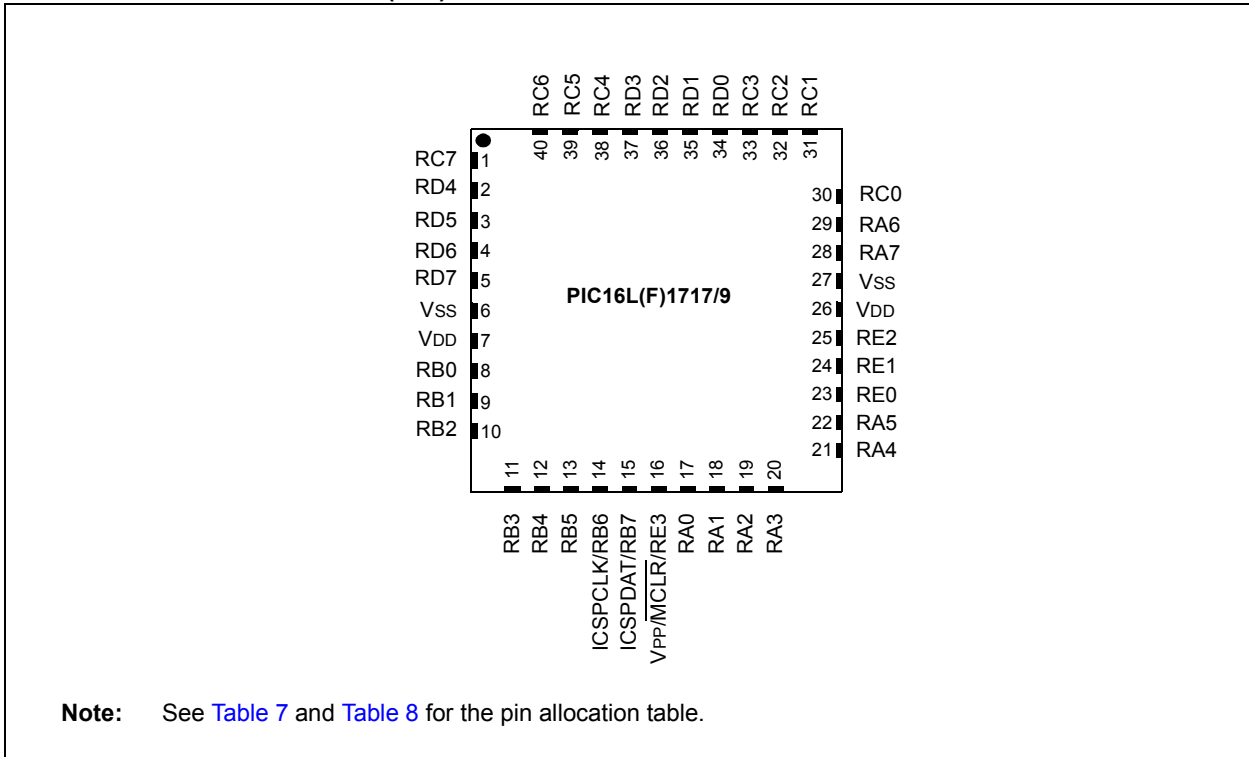

TABLE 1: 14-PIN AND 16-PIN ALLOCATION TABLE (PIC16(L)F1703)

I/O ⁽²⁾	PDIP/SOIC/SSOP	QFN	ADC	Reference	Op Amp	Zero Cross	Timers	CCP	MSSP	CLC	Interrupt	Pull-up	Basic
RA0	13	12	AN0	VREF-	—	—	—	—	—	—	IOC	Y	ICSPDAT
RA1	12	11	AN1	VREF+	—	—	—	—	—	—	IOC	Y	ICSPCLK
RA2	11	10	AN2	—	—	ZCD	T0CKI ⁽¹⁾	—	—	—	INT ⁽¹⁾ IOC	Y	—
RA3	4	3	—	—	—	—	—	—	—	—	IOC	Y	$\overline{\text{MCLR}}$ V _{PP}
RA4	3	2	AN3	—	—	—	T1G ⁽¹⁾	—	—	—	IOC	Y	CLKOUT
RA5	2	1	—	—	—	—	T1CKI ⁽¹⁾	—	—	—	IOC	Y	CLKIN
RC0	10	9	AN4	—	OPA1IN+	—	—	—	SCK ⁽¹⁾ SCL ⁽³⁾	—	IOC	Y	—
RC1	9	8	AN5	—	OPA1IN-	—	—	—	SDI ⁽¹⁾ SDA ⁽³⁾	—	IOC	Y	—
RC2	8	7	AN6	—	OPA1OUT	—	—	—	—	—	IOC	Y	—
RC3	7	6	AN7	—	OPA2OUT	—	—	CCP2 ⁽¹⁾	$\overline{\text{SS}}$ ⁽¹⁾	—	IOC	Y	—
RC4	6	5	—	—	OPA2IN-	—	—	—	—	—	IOC	Y	—
RC5	5	4	—	—	OPA2IN+	—	—	CCP1 ⁽¹⁾	—	—	IOC	Y	—
V _{DD}	1	16	—	—	—	—	—	—	—	—	—	—	V _{DD}
V _{SS}	14	13	—	—	—	—	—	—	—	—	—	—	V _{SS}
OUT ⁽²⁾	—	—	—	—	—	—	—	CPP1	SDA ⁽³⁾	—	—	—	—
	—	—	—	—	—	—	—	CPP2	SCL ⁽³⁾ SCK	—	—	—	—
	—	—	—	—	—	—	—	—	SDO	—	—	—	—

- Note**
- 1: Default peripheral input. Input can be moved to any other pin with the PPS input selection registers.
 - 2: All pin digital outputs default to PORT latch data. Any pin can be selected as a peripheral digital output with the PPS output selection registers.
 - 3: These peripheral functions are bidirectional. The output pin selections must be the same as the input pin selections.

TABLE 2: 14-PIN AND 16-PIN ALLOCATION TABLE (PIC16(L)F1704/5)

I/O ⁽²⁾	PDIP/SOIC/SSOP	QFN	ADC	Reference	Comparator	Op Amp	DAC	Zero Cross	Timers	CCP	PWM	COG	MSSP	EUSART	CLC	Interrupt	Pull-up	Basic
RA0	13	12	AN0	VREF-	C1IN+	—	DAC1OUT	—	—	—	—	—	—	—	—	IOE	Y	ICSPDAT
RA1	12	11	AN1	VREF+	C1IN0- C2IN0-	—	—	—	—	—	—	—	—	—	—	IOE	Y	ICSPCLK
RA2	11	10	AN2	—	—	—	DAC1OUT2	ZCD	T0CKI ⁽¹⁾	—	—	COGIN ⁽¹⁾	—	—	—	INT ⁽¹⁾ IOE	Y	—
RA3	4	3	—	—	—	—	—	—	—	—	—	—	—	—	—	IOE	Y	MCLR V _{PP}
RA4	3	2	AN3	—	—	—	—	—	T1G ⁽¹⁾ SOSCO	—	—	—	—	—	—	IOE	Y	CLKOUT OSC2
RA5	2	1	—	—	—	—	—	—	T1CKI ⁽¹⁾ SOSCI	—	—	—	—	—	CLCIN3 ⁽¹⁾	IOE	Y	CLKIN OSC1
RC0	10	9	AN4	—	C2IN+	OPA1IN+	—	—	—	—	—	—	SCK ⁽¹⁾ SCL ⁽³⁾	—	—	IOE	Y	—
RC1	9	8	AN5	—	C1IN1- C2IN1-	OPA1IN-	—	—	—	—	—	—	SDI ⁽¹⁾ SDA ⁽³⁾	—	CLCIN2 ⁽¹⁾	IOE	Y	—
RC2	8	7	AN6	—	C1IN2- C2IN2-	OPA1OUT	—	—	—	—	—	—	—	—	—	IOE	Y	—
RC3	7	6	AN7	—	C1IN3- C2IN3-	OPA2OUT	—	—	—	CCP2 ⁽¹⁾	—	—	SS ⁽¹⁾	—	CLCIN0 ⁽¹⁾	IOE	Y	—
RC4	6	5	—	—	—	OPA2IN-	—	—	—	—	—	—	—	CK ⁽¹⁾	CLCIN1 ⁽¹⁾	IOE	Y	—
RC5	5	4	—	—	—	OPA2IN+	—	—	—	CCP1 ⁽¹⁾	—	—	—	RX ⁽³⁾	—	IOE	Y	—
V _{DD}	1	16	—	—	—	—	—	—	—	—	—	—	—	—	—	—	—	V _{DD}
V _{SS}	14	13	—	—	—	—	—	—	—	—	—	—	—	—	—	—	—	V _{SS}
OUT ⁽²⁾	—	—	—	—	C1OUT	—	—	—	—	CPP1	PWM3OUT	COGA	SDA ⁽³⁾	CK	CLC1OUT	—	—	—
	—	—	—	—	C2OUT	—	—	—	—	CPP2	PWM4OUT	COGB	SCL ⁽³⁾	DT ⁽³⁾	CLC2OUT	—	—	—
	—	—	—	—	—	—	—	—	—	—	—	COGC	SDO	TX	CLC3OUT	—	—	—
	—	—	—	—	—	—	—	—	—	—	—	COGD	SCK	—	—	—	—	—

- Note**
- 1: Default peripheral input. Input can be moved to any other pin with the PPS input selection registers.
 - 2: All pin digital outputs default to PORT latch data. Any pin can be selected as a peripheral digital output with the PPS output selection registers.
 - 3: These peripheral functions are bidirectional. The output pin selections must be the same as the input pin selections.

TABLE 3: 20-PIN ALLOCATION TABLE (PIC16(L)F1707)

(IO/I)	PDIP/SOIC/ SSOP	QFN	ADC	Reference	Op Amp	Zero Cross	Timers	CCP	MSSP	Interrupt	Pull-up	Basic
RA0	19	16	AN0	VREF-	—	—	—	—	—	IOC	Y	ICSPDAT
RA1	18	15	AN1	VREF+	—	—	—	—	—	IOC	Y	ICSPCLK
RA2	17	14	AN2	—	—	ZCD	T0CKI ⁽¹⁾	—	—	INT ⁽¹⁾ IOC	Y	—
RA3	4	1	—	—	—	—	—	—	—	IOC	Y	MCLR V _{PP}
RA4	3	20	AN3	—	—	—	T1G ⁽¹⁾	—	—	IOC	Y	CLKOUT
RA5	2	19	—	—	—	—	T1CKI	—	—	IOC	Y	CLKIN
RB4	13	10	AN10	—	OPA1IN-	—	—	—	SCK ⁽¹⁾ SDA ⁽³⁾	IOC	Y	—
RB5	12	9	AN11	—	OPA1IN+	—	—	—	—	IOC	Y	—
RB6	11	8	—	—	—	—	—	—	SDI ⁽¹⁾ SCL ⁽³⁾	IOC	Y	—
RB7	10	7	—	—	—	—	—	—	—	IOC	Y	—
RC0	16	13	AN4	—	—	—	—	—	—	IOC	Y	—
RC1	15	12	AN5	—	—	—	—	—	—	IOC	Y	—
RC2	14	11	AN6	—	OPA1OUT	—	—	—	—	IOC	Y	—
RC3	7	4	AN7	—	OPA2OUT	—	—	CCP2 ⁽¹⁾	—	IOC	Y	—
RC4	6	3	—	—	OPA2IN-	—	—	—	—	IOC	Y	—
RC5	5	2	—	—	OPA2IN+	—	—	CCP1 ⁽¹⁾	—	IOC	Y	—
RC6	8	5	AN8	—	—	—	—	—	SS ⁽¹⁾	IOC	Y	—
RC7	9	6	AN9	—	—	—	—	—	—	IOC	Y	—
V _{DD}	1	18	—	—	—	—	—	—	—	—	—	V _{DD}
V _{SS}	20	17	—	—	—	—	—	—	—	—	—	V _{SS}
OUT ⁽²⁾	—	—	—	—	—	—	—	CPP1	SDA ⁽³⁾	—	—	—
	—	—	—	—	—	—	—	CPP2	SCL ⁽³⁾ SCK	—	—	—
	—	—	—	—	—	—	—	—	SDO	—	—	—

- Note**
- 1: Default peripheral input. Input can be moved to any other pin with the PPS input selection registers.
 - 2: All pin digital outputs default to PORT latch data. Any pin can be selected as a peripheral digital output with the PPS output selection registers.
 - 3: These peripheral functions are bidirectional. The output pin selections must be the same as the input pin selections.

TABLE 4: 20-PIN ALLOCATION TABLE (PIC16(L)F1708/9)

I/O ⁽²⁾	PDIP/SOIC/ SSOP	QFN	ADC	Reference	Comparator	Op Amp	DAC	Zero Cross	Timers	CCP	PWM	COG	MSSP	EUSART	CLC	Interrupt	Pull-up	Basic
RA0	19	16	AN0	VREF-	C1IN+	—	DAC1OUT	—	—	—	—	—	—	—	—	IOC	Y	ICSPDAT
RA1	18	15	AN1	VREF+	C1IN0- C2IN0-	—	—	—	—	—	—	—	—	—	—	IOC	Y	ICSPCLK
RA2	17	14	AN2	—	—	—	DAC1OUT2	ZCD	TOCKI ⁽¹⁾	—	—	COGIN ⁽¹⁾	—	—	—	INT ⁽¹⁾ IOC	Y	—
RA3	4	1	—	—	—	—	—	—	—	—	—	—	—	—	—	IOC	Y	MCLR VPP
RA4	3	20	AN3	—	—	—	—	—	T1G ⁽¹⁾ SOSCO	—	—	—	—	—	—	IOC	Y	CLKOUT OSC2
RA5	2	19	—	—	—	—	—	—	T1CKI SOSCI	—	—	—	—	—	CLCIN3 ⁽¹⁾	IOC	Y	CLKIN OSC1
RB4	13	10	AN10	—	—	OPA1IN-	—	—	—	—	—	—	SCK ⁽¹⁾ SDA ⁽³⁾	—	—	IOC	Y	—
RB5	12	9	AN11	—	—	OPA1IN+	—	—	—	—	—	—	—	RX ⁽¹⁾ (3)	—	IOC	Y	—
RB6	11	8	—	—	—	—	—	—	—	—	—	—	SDI ⁽¹⁾ SCL ⁽³⁾	—	—	IOC	Y	—
RB7	10	7	—	—	—	—	—	—	—	—	—	—	—	CK ⁽¹⁾ (3)	—	IOC	Y	—
RC0	16	13	AN4	—	C2IN+	—	—	—	—	—	—	—	—	—	—	IOC	Y	—
RC1	15	12	AN5	—	C1IN1- C2IN1-	—	—	—	—	—	—	—	—	—	CLCIN2 ⁽¹⁾	IOC	Y	—
RC2	14	11	AN6	—	C1IN2- C2IN2-	OPA1OUT	—	—	—	—	—	—	—	—	—	IOC	Y	—
RC3	7	4	AN7	—	C1IN3- C2IN3-	OPA2OUT	—	—	—	CCP2 ⁽¹⁾	—	—	—	—	CLCIN0 ⁽¹⁾	IOC	Y	—
RC4	6	3	—	—	—	OPA2IN-	—	—	—	—	—	—	—	—	CLCIN1 ⁽¹⁾	IOC	Y	—
RC5	5	2	—	—	—	OPA2IN+	—	—	—	CCP1 ⁽¹⁾	—	—	—	—	—	IOC	Y	—
RC6	8	5	AN8	—	—	—	—	—	—	—	—	—	SS ⁽¹⁾	—	—	IOC	Y	—
RC7	9	6	AN9	—	—	—	—	—	—	—	—	—	—	—	—	IOC	Y	—
VDD	1	18	—	—	—	—	—	—	—	—	—	—	—	—	—	—	—	VDD
VSS	20	17	—	—	—	—	—	—	—	—	—	—	—	—	—	—	—	VSS

- Note**
- 1: Default peripheral input. Input can be moved to any other pin with the PPS input selection registers.
 - 2: All pin digital outputs default to PORT latch data. Any pin can be selected as a peripheral digital output with the PPS output selection registers.
 - 3: These peripheral functions are bidirectional. The output pin selections must be the same as the input pin selections.

I/O ⁽²⁾	PDIP/SOIC/ SSOP	QFN	ADC	Reference	Comparator	Op Amp	DAC	Zero Cross	Timers	CCP	PWM	COG	MSSP	EUSART	CLC	Interrupt	Pull-up	Basic
OUT ⁽²⁾	—	—	—	—	C1OUT	—	—	—	—	CPP1	PWM3OUT	COGA	SDA ⁽³⁾	CK	CLC1OUT	—	—	—
	—	—	—	—	C2OUT	—	—	—	—	CPP2	PWM4OUT	COGB	SCL ⁽³⁾	DT	CLC2OUT	—	—	—
	—	—	—	—	—	—	—	—	—	—	—	COGC	SDO	TX	CLC3OUT	—	—	—
	—	—	—	—	—	—	—	—	—	—	—	COGD	—	—	—	—	—	—

- Note**
- 1: Default peripheral input. Input can be moved to any other pin with the PPS input selection registers.
 - 2: All pin digital outputs default to PORT latch data. Any pin can be selected as a peripheral digital output with the PPS output selection registers.
 - 3: These peripheral functions are bidirectional. The output pin selections must be the same as the input pin selections.

TABLE 5: 28-PIN ALLOCATION TABLE (PIC16L(F)1713/6/8) (PART 1)

I/O ⁽²⁾	PDIP, SOIC, SSOP	QFN, UQFN	ADC	Reference	Comparator	Op Amp	DAC	Zero Cross	Timers	CCP	NCO	PWM	COG	MSSP	EUSART	CLC	Interrupt	Pull-up	Basic	
RA0	2	27	AN0		C1IN0- C2IN0-											CLCIN0 ⁽¹⁾	IOC	Y		
RA1	3	28	AN1		C1IN1- C2IN1-	OPA1OUT										CLCIN1 ⁽¹⁾	IOC	Y		
RA2	4	1	AN2	Vref-	C1IN0+ C2IN0+		DAC1OUT1											IOC	Y	
RA3	5	2	AN3	Vref+	C1IN1+													IOC	Y	
RA4	6	3				OPA1IN+			T0CKI ⁽¹⁾									IOC	Y	
RA5	7	4	AN4			OPA1IN-	DAC2OUT1							nSS ⁽¹⁾				IOC	Y	
RA6	10	7																IOC		OSC2 CLKOUT
RA7	9	6									NCOCLK							IOC		OSC1 CLKIN
RB0	21	18	AN12		C2IN1+			ZCD					COGIN ⁽¹⁾					INT ⁽¹⁾ IOC		
RB1	22	19	AN10		C1IN3- C2IN3-	OPA2OUT												IOC		
RB2	23	20	AN8			OPA2IN-												IOC		
RB3	24	21	AN9		C1IN2- C2IN2-	OPA2IN+												IOC		
RB4	25	22	AN11															IOC	Y	
RB5	26	23	AN13						T1G ⁽¹⁾									IOC	Y	
RB6	27	24												SCL ⁽¹⁾		CLCIN2 ⁽¹⁾	IOC	Y	ICSPCLK	
RB7	28	25					DAC1OUT2 DAC2OUT2									CLCIN3 ⁽¹⁾	IOC	Y	ICSPDAT	
RC0	11	8							T1CKI ⁽¹⁾ SOSCO									IOC	Y	
RC1	12	9							SOSCI	CCP2 ⁽¹⁾								IOC	Y	
RC2	13	10	AN14							CCP1 ⁽¹⁾								IOC	Y	
RC3	14	11	AN15											SCK ⁽¹⁾				IOC	Y	

Note 1: Default peripheral input. Alternate pins can be selected as the peripheral input with the PPS input selection registers.

Note 2: All pin digital outputs default to PORT latch data. Alternate outputs can be selected as the peripheral digital output with the PPS output selection registers.

Note 3: These peripheral functions are bidirectional. The output pin selections must be the same as the input pin selections.

Note 4: Alternate outputs are excluded from solid shaded areas.

Note 5: Alternate inputs are excluded from dot shaded areas.

TABLE 6: 28-PIN ALLOCATION TABLE (PIC16L(F)1713/6/8) (PART 2)

I/O ⁽²⁾	PDIP,SOIC, SSOP	QFN, UQFN	ADC	Reference	Comparator	Op Amp	DAC	Zero Cross	Timers	CCP	NCO	PWM	COG	MSSP	EUSART	CLC	Interrupt	Pull-up	Basic
RC4	15	12	AN16											SDI ⁽¹⁾ SDA ⁽¹⁾			IOC	Y	
RC5	16	13	AN17														IOC	Y	
RC6	17	14	AN18												CK ⁽³⁾		IOC	Y	
RC7	18	15	AN19												RX ⁽³⁾		IOC	Y	
RE3	1	26																	MCLR
Vdd	20	17																	Vpp
Vss	8	5																	Vdd
	19	16																	Vss
OUT ⁽⁴⁾					C1OUT C2OUT					CCP1 CCP2	NCOOUT	PWM3OUT PWM4OUT	COGA COGB COGC COGD	SDA ⁽³⁾ SCK/SCL ⁽³⁾ SDO	TX/CK DT ⁽³⁾	CLC1OUT CLC2OUT CLC3OUT CLC4OUT			
IN ⁽⁵⁾									T1G T1CKI T0CKI	CCP1 CCP2	NCOCLK		COGIN	SDI SCK/SCL ⁽³⁾ SS	RX ⁽³⁾ CK	CLCIN0 CLCIN1 CLCIN2 CLCIN3	INT		

Note 1: Default peripheral input. Alternate pins can be selected as the peripheral input with the PPS input selection registers.

Note 2: All pin digital outputs default to PORT latch data. Alternate outputs can be selected as the peripheral digital output with the PPS output selection registers.

Note 3: These peripheral functions are bidirectional. The output pin selections must be the same as the input pin selections.

Note 4: Alternate outputs are excluded from solid shaded areas.

Note 5: Alternate inputs are excluded from dot shaded areas.

TABLE 7: PIN ALLOCATION TABLE (PIC16(L)F1717/9) (PART 1)

I/O ⁽²⁾	PDIP	TQFP	UQFN	ADC	Reference	Comparator	Op Amp	DAC	Zero Cross	Timers	CCP	NCO	PWM	COG	MSSP	EUSART	CLC	Interrupt	Pullup	Basic
RA0	2	19	17	AN0		C1IN0- C2IN0-											CLCIN0 ⁽¹⁾	IOC	Y	
RA1	3	20	18	AN1		C1IN1- C2IN1-	OPA1OUT										CLCIN1 ⁽¹⁾	IOC	Y	
RA2	4	21	19	AN2	Vref-	C1IN0+ C2IN0+		DAC1OUT1											IOC	Y
RA3	5	22	20	AN3	Vref+	C1IN1+													IOC	Y
RA4	6	23	21				OPA1IN+			TOCKI ⁽¹⁾									IOC	Y
RA5	7	24	22	AN4			OPA1IN-	DAC2OUT1							nSS ⁽¹⁾				IOC	Y
RA6	14	31	29																IOC	OSC2 CLKOUT
RA7	13	30	28									NCOCLK							IOC	OSC1 CLKIN
RB0	33	8	8	AN12		C2IN1+			ZCD					COGIN ⁽¹⁾					INT ⁽¹⁾ IOC	
RB1	34	9	9	AN10		C1IN3- C2IN3-	OPA2OUT												IOC	
RB2	35	10	10	AN8			OPA2IN-												IOC	
RB3	36	11	11	AN9		C1IN2- C2IN2-	OPA2IN+												IOC	
RB4	37	14	12	AN11															IOC	Y
RB5	38	15	13	AN13						T1G ⁽¹⁾									IOC	Y
RB6	39	16	14												SCL ⁽¹⁾		CLCIN2 ⁽¹⁾	IOC	Y	ICSPCLK
RB7	40	17	15					DAC1OUT2 DAC2OUT2									CLCIN3 ⁽¹⁾	IOC	Y	ICSPDAT
RC0	15	32	30							T1CKI ⁽¹⁾ SOSCO									IOC	Y
RC1	16	35	31							SOSCI	CCP2 ⁽¹⁾								IOC	Y
RC2	17	36	32	AN14							CCP1 ⁽¹⁾								IOC	Y
RC3	18	37	33	AN15											SCK ⁽¹⁾				IOC	Y
RC4	23	42	38	AN16											SDI ⁽¹⁾ SDA ⁽¹⁾				IOC	Y

Note 1: Default peripheral input. Alternate pins can be selected as the peripheral input with the PPS input selection registers.

Note 2: All pin digital outputs default to PORT latch data. Alternate outputs can be selected as the peripheral digital output with the PPS output selection registers.

Note 3: These peripheral functions are bidirectional. The output pin selections must be the same as the input pin selections.

Note 4: Alternate outputs are excluded from solid shaded areas.

TABLE 8: PIN ALLOCATION TABLE (PIC16L(F)1717/9) (PART 2)

I/O ⁽²⁾	PDIP	TQFP	UQFN	ADC	Reference	Comparator	Op Amp	DAC	Zero Cross	Timers	CCP	NCO	PWM	COG	MSSP	EUSART	CLC	Interrupt	Pullup	Basic
RC5	24	43	39	AN17														IOC	Y	
RC6	25	44	40	AN18												CK ⁽³⁾		IOC	Y	
RC7	26	1	1	AN19												RX ⁽³⁾		IOC	Y	
RD0	19	38	34	AN20																
RD1	20	39	35	AN21																
RD2	21	40	36	AN22																
RD3	22	41	37	AN23																
RD4	27	2	2	AN24																
RD5	28	3	3	AN25																
RD6	29	4	4	AN26																
RD7	30	5	5																	
RE0	8	25	23	AN5																
RE1	9	26	24	AN6																
RE2	10	27	25	AN7																
RE3	1	18	16																	MCLR
Vdd	11	7	7																	Vpp
	32	28	26																	Vdd
Vss	12	6	6																	Vss
	31	29	27																	
OUT ⁽⁴⁾						C1OUT C2OUT					CCP1 CCP2	NCOOUT	PWM3OUT PWM4OUT	COGA COGB COGC COGD	SDA ⁽³⁾ SCK/SCL ⁽³⁾	SDO TX/CK	DT (3)	CLC1OUT CLC2OUT CLC3OUT CLC4OUT		
IN ⁽⁵⁾										T1G T1CKI T0CKI	CCP1 CCP2	NCOCLK		COGIN	SDI SCK/SCL ⁽³⁾ SS	RX (3) CK	CLCIN0 CLCIN1 CLCIN2 CLCIN3	INT		

Note 1: Default peripheral input. Alternate pins can be selected as the peripheral input with the PPS input selection registers.

Note 2: All pin digital outputs default to PORT latch data. Alternate outputs can be selected as the peripheral digital output with the PPS output selection registers.

Note 3: These peripheral functions are bidirectional. The output pin selections must be the same as the input pin selections.

Note 4: Alternate outputs are excluded from solid shaded areas.

Note 5: Alternate inputs are excluded from dot shaded areas.

Note the following details of the code protection feature on Microchip devices:

- Microchip products meet the specification contained in their particular Microchip Data Sheet.
- Microchip believes that its family of products is one of the most secure families of its kind on the market today, when used in the intended manner and under normal conditions.
- There are dishonest and possibly illegal methods used to breach the code protection feature. All of these methods, to our knowledge, require using the Microchip products in a manner outside the operating specifications contained in Microchip's Data Sheets. Most likely, the person doing so is engaged in theft of intellectual property.
- Microchip is willing to work with the customer who is concerned about the integrity of their code.
- Neither Microchip nor any other semiconductor manufacturer can guarantee the security of their code. Code protection does not mean that we are guaranteeing the product as “unbreakable.”

Code protection is constantly evolving. We at Microchip are committed to continuously improving the code protection features of our products. Attempts to break Microchip's code protection feature may be a violation of the Digital Millennium Copyright Act. If such acts allow unauthorized access to your software or other copyrighted work, you may have a right to sue for relief under that Act.

Information contained in this publication regarding device applications and the like is provided only for your convenience and may be superseded by updates. It is your responsibility to ensure that your application meets with your specifications. MICROCHIP MAKES NO REPRESENTATIONS OR WARRANTIES OF ANY KIND WHETHER EXPRESS OR IMPLIED, WRITTEN OR ORAL, STATUTORY OR OTHERWISE, RELATED TO THE INFORMATION, INCLUDING BUT NOT LIMITED TO ITS CONDITION, QUALITY, PERFORMANCE, MERCHANTABILITY OR FITNESS FOR PURPOSE. Microchip disclaims all liability arising from this information and its use. Use of Microchip devices in life support and/or safety applications is entirely at the buyer's risk, and the buyer agrees to defend, indemnify and hold harmless Microchip from any and all damages, claims, suits, or expenses resulting from such use. No licenses are conveyed, implicitly or otherwise, under any Microchip intellectual property rights.

Trademarks

The Microchip name and logo, the Microchip logo, dsPIC, FlashFlex, KEELOQ, KEELOQ logo, MPLAB, PIC, PICmicro, PICSTART, PIC³² logo, rPIC, SST, SST Logo, SuperFlash and UNI/O are registered trademarks of Microchip Technology Incorporated in the U.S.A. and other countries.

FilterLab, Hampshire, HI-TECH C, Linear Active Thermistor, MTP, SEEVAL and The Embedded Control Solutions Company are registered trademarks of Microchip Technology Incorporated in the U.S.A.

Silicon Storage Technology is a registered trademark of Microchip Technology Inc. in other countries.

Analog-for-the-Digital Age, Application Maestro, BodyCom, chipKIT, chipKIT logo, CodeGuard, dsPICDEM, dsPICDEM.net, dsPICworks, dsSPEAK, ECAN, ECONOMONITOR, FanSense, HI-TIDE, In-Circuit Serial Programming, ICSP, Mindi, MiWi, MPASM, MPF, MPLAB Certified logo, MPLIB, MPLINK, mTouch, Omniclient Code Generation, PICC, PICC-18, PICDEM, PICDEM.net, PICkit, PICtail, REAL ICE, rLAB, Select Mode, SQI, Serial Quad I/O, Total Endurance, TSHARC, UniWinDriver, WiperLock, ZENA and Z-Scale are trademarks of Microchip Technology Incorporated in the U.S.A. and other countries.

SQTP is a service mark of Microchip Technology Incorporated in the U.S.A.

GestIC and ULPP are registered trademarks of Microchip Technology Germany II GmbH & Co. KG, a subsidiary of Microchip Technology Inc., in other countries.

All other trademarks mentioned herein are property of their respective companies.

© 2013, Microchip Technology Incorporated, Printed in the U.S.A., All Rights Reserved.

 Printed on recycled paper.

ISBN: 9781620772942

QUALITY MANAGEMENT SYSTEM
CERTIFIED BY DNV
== ISO/TS 16949 ==

Microchip received ISO/TS-16949:2009 certification for its worldwide headquarters, design and wafer fabrication facilities in Chandler and Tempe, Arizona; Gresham, Oregon and design centers in California and India. The Company's quality system processes and procedures are for its PIC[®] MCUs and dsPIC[®] DSCs, KEELOQ[®] code hopping devices, Serial EEPROMs, microperipherals, nonvolatile memory and analog products. In addition, Microchip's quality system for the design and manufacture of development systems is ISO 9001:2000 certified.



MICROCHIP

Worldwide Sales and Service

AMERICAS

Corporate Office
2355 West Chandler Blvd.
Chandler, AZ 85224-6199
Tel: 480-792-7200
Fax: 480-792-7277
Technical Support:
<http://www.microchip.com/support>
Web Address:
www.microchip.com

Atlanta
Duluth, GA
Tel: 678-957-9614
Fax: 678-957-1455

Boston
Westborough, MA
Tel: 774-760-0087
Fax: 774-760-0088

Chicago
Itasca, IL
Tel: 630-285-0071
Fax: 630-285-0075

Cleveland
Independence, OH
Tel: 216-447-0464
Fax: 216-447-0643

Dallas
Addison, TX
Tel: 972-818-7423
Fax: 972-818-2924

Detroit
Farmington Hills, MI
Tel: 248-538-2250
Fax: 248-538-2260

Indianapolis
Noblesville, IN
Tel: 317-773-8323
Fax: 317-773-5453

Los Angeles
Mission Viejo, CA
Tel: 949-462-9523
Fax: 949-462-9608

Santa Clara
Santa Clara, CA
Tel: 408-961-6444
Fax: 408-961-6445

Toronto
Mississauga, Ontario,
Canada
Tel: 905-673-0699
Fax: 905-673-6509

ASIA/PACIFIC

Asia Pacific Office
Suites 3707-14, 37th Floor
Tower 6, The Gateway
Harbour City, Kowloon
Hong Kong
Tel: 852-2401-1200
Fax: 852-2401-3431

Australia - Sydney
Tel: 61-2-9868-6733
Fax: 61-2-9868-6755

China - Beijing
Tel: 86-10-8569-7000
Fax: 86-10-8528-2104

China - Chengdu
Tel: 86-28-8665-5511
Fax: 86-28-8665-7889

China - Chongqing
Tel: 86-23-8980-9588
Fax: 86-23-8980-9500

China - Hangzhou
Tel: 86-571-2819-3187
Fax: 86-571-2819-3189

China - Hong Kong SAR
Tel: 852-2943-5100
Fax: 852-2401-3431

China - Nanjing
Tel: 86-25-8473-2460
Fax: 86-25-8473-2470

China - Qingdao
Tel: 86-532-8502-7355
Fax: 86-532-8502-7205

China - Shanghai
Tel: 86-21-5407-5533
Fax: 86-21-5407-5066

China - Shenyang
Tel: 86-24-2334-2829
Fax: 86-24-2334-2393

China - Shenzhen
Tel: 86-755-8864-2200
Fax: 86-755-8203-1760

China - Wuhan
Tel: 86-27-5980-5300
Fax: 86-27-5980-5118

China - Xian
Tel: 86-29-8833-7252
Fax: 86-29-8833-7256

China - Xiamen
Tel: 86-592-2388138
Fax: 86-592-2388130

China - Zhuhai
Tel: 86-756-3210040
Fax: 86-756-3210049

ASIA/PACIFIC

India - Bangalore
Tel: 91-80-3090-4444
Fax: 91-80-3090-4123

India - New Delhi
Tel: 91-11-4160-8631
Fax: 91-11-4160-8632

India - Pune
Tel: 91-20-2566-1512
Fax: 91-20-2566-1513

Japan - Osaka
Tel: 81-6-6152-7160
Fax: 81-6-6152-9310

Japan - Tokyo
Tel: 81-3-6880-3770
Fax: 81-3-6880-3771

Korea - Daegu
Tel: 82-53-744-4301
Fax: 82-53-744-4302

Korea - Seoul
Tel: 82-2-554-7200
Fax: 82-2-558-5932 or
82-2-558-5934

Malaysia - Kuala Lumpur
Tel: 60-3-6201-9857
Fax: 60-3-6201-9859

Malaysia - Penang
Tel: 60-4-227-8870
Fax: 60-4-227-4068

Philippines - Manila
Tel: 63-2-634-9065
Fax: 63-2-634-9069

Singapore
Tel: 65-6334-8870
Fax: 65-6334-8850

Taiwan - Hsin Chu
Tel: 886-3-5778-366
Fax: 886-3-5770-955

Taiwan - Kaohsiung
Tel: 886-7-213-7828
Fax: 886-7-330-9305

Taiwan - Taipei
Tel: 886-2-2508-8600
Fax: 886-2-2508-0102

Thailand - Bangkok
Tel: 66-2-694-1351
Fax: 66-2-694-1350

EUROPE

Austria - Wels
Tel: 43-7242-2244-39
Fax: 43-7242-2244-393

Denmark - Copenhagen
Tel: 45-4450-2828
Fax: 45-4485-2829

France - Paris
Tel: 33-1-69-53-63-20
Fax: 33-1-69-30-90-79

Germany - Munich
Tel: 49-89-627-144-0
Fax: 49-89-627-144-44

Italy - Milan
Tel: 39-0331-742611
Fax: 39-0331-466781

Netherlands - Drunen
Tel: 31-416-690399
Fax: 31-416-690340

Spain - Madrid
Tel: 34-91-708-08-90
Fax: 34-91-708-08-91

UK - Wokingham
Tel: 44-118-921-5869
Fax: 44-118-921-5820

11/29/12

Mouser Electronics

Authorized Distributor

Click to View Pricing, Inventory, Delivery & Lifecycle Information:

Microchip:

[PIC16F1713-I/SP](#) [PIC16F1703-I/SL](#) [PIC16F1716-E/SP](#) [PIC16F1707-E/SO](#) [PIC16F1707-E/SS](#) [PIC16F1716-I/SS](#)
[PIC16F1713-I/SO](#) [PIC16F1707-I/P](#) [PIC16F1716-E/SS](#) [PIC16F1707-I/SS](#) [PIC16F1713T-I/SS](#) [PIC16F1713-E/SP](#)
[PIC16F1713-E/MV](#) [PIC16F1707-E/ML](#) [PIC16F1707-E/P](#) [PIC16F1716-E/MV](#) [PIC16F1716T-I/SO](#) [PIC16F1703-I/P](#)
[PIC16F1716-I/MV](#) [PIC16F1703-E/ML](#) [PIC16F1707-I/ML](#) [PIC16F1703T-I/ST](#) [PIC16F1713T-I/MV](#) [PIC16F1707T-I/SO](#)
[PIC16F1713-E/SO](#) [PIC16F1716-I/SP](#) [PIC16F1703-E/P](#) [PIC16F1713T-I/SO](#) [PIC16F1716T-I/MV](#) [PIC16F1703T-I/SL](#)
[PIC16F1713-I/SS](#) [PIC16F1707-I/SO](#) [PIC16F1716T-I/SS](#) [PIC16F1713-I/MV](#) [PIC16F1703-E/ST](#) [PIC16F1716-I/SO](#)
[PIC16F1703-E/SL](#) [PIC16F1703-I/ST](#) [PIC16F1716-E/SO](#) [PIC16F1703-I/ML](#) [PIC16F1713-E/SS](#) [PIC16F1707T-I/SS](#)
[PIC16F1703T-I/ML](#) [PIC16LF1703-I/SL](#) [PIC16LF1703-I/P](#) [PIC16LF1707-I/P](#) [PIC16F1705-I/ML](#) [PIC16LF1705-E/P](#)
[PIC16LF1705-I/ML](#) [PIC16LF1716T-I/SO](#) [PIC16F1709-E/SO](#) [PIC16LF1713T-I/SS](#) [PIC16LF1705T-I/ML](#) [PIC16LF1713-](#)
[I/SS](#) [PIC16LF1716-I/SP](#) [PIC16LF1709T-I/ML](#) [PIC16F1705-E/ML](#) [PIC16F1709T-I/SO](#) [PIC16F1705-E/P](#)
[PIC16LF1705T-I/ST](#) [PIC16F1705T-I/ST](#) [PIC16LF1713-E/SS](#) [PIC16LF1716-I/SO](#) [PIC16LF1716-E/SP](#) [PIC16LF1713-](#)
[I/SP](#) [PIC16LF1716-I/MV](#) [PIC16LF1713-E/SP](#) [PIC16LF1705-E/ST](#) [PIC16LF1713-I/MV](#) [PIC16F1709-E/SS](#)
[PIC16LF1713T-I/MV](#) [PIC16LF1716-E/MV](#) [PIC16F1705-E/SL](#) [PIC16F1705T-I/SL](#) [PIC16F1709-I/ML](#) [PIC16LF1709-](#)
[E/SS](#) [PIC16LF1713-E/SO](#) [PIC16LF1716T-I/SS](#) [PIC16LF1709T-I/SS](#) [PIC16LF1709-E/ML](#) [PIC16LF1713T-I/SO](#)
[PIC16LF1705-E/ML](#) [PIC16F1709-E/P](#) [PIC16LF1713-E/MV](#) [PIC16LF1716-E/SO](#) [PIC16LF1709-E/SO](#) [PIC16LF1716-](#)
[E/SS](#) [PIC16F1709-E/ML](#) [PIC16F1709T-I/SS](#) [PIC16LF1705-E/SL](#) [PIC16LF1709-E/P](#) [PIC16LF1716T-I/MV](#)
[PIC16F1709T-I/ML](#) [PIC16LF1709-I/SS](#) [PIC16F1705-E/ST](#) [PIC16LF1709-I/ML](#) [PIC16LF1705-I/ST](#) [PIC16LF1709-I/SO](#)
[PIC16LF1705T-I/SL](#) [PIC16LF1713-I/SO](#)