20-Pin Flash, 8-Bit Microcontrollers with XLP Technology

Description:

The PIC16LF1554/1559 microcontrollers with Microchip enhanced mid-range core deliver unique on-chip features for the design of mTouch[®] solutions and general purpose applications in 14/20-pin count packages. Up to 17 analog channels connecting to two 10-bit ADCs with automated hardware CVD modules, two PWMs and multiple communication peripherals offer an excellent solution to implement capacitive sensing and other front-end sampling applications with minimal software overhead.

High-Performance RISC CPU:

- Only 49 Instructions to Learn
- Operating Speed:
 - DC – 32 MHz clock input
 - DC – 125 ns instruction cycle
- Interrupt Capability with Automatic Context Saving
- 16-Level Deep Hardware Stack with Optional Overflow/Underflow Reset
- Direct, Indirect and Relative Addressing modes:
 - Two full 16-bit File Select Registers (FSRs)
 - FSRs can read program and data memory

Special Microcontroller Features:

- Precision 16 MHz Internal Oscillator:
 - Factory calibrated to $\pm 1\%$, typical
 - Software selectable frequency range from 32 MHz to 31 kHz
- 31 kHz Low-Power Internal Oscillator
- 4x Phase-Locked Loop (PLL)
- Power-Saving Sleep mode
- Power-on Reset (POR)
- Power-up Timer (PWRT)
- BOR with Selectable Trip Point
- Low-Power Brown-Out Reset (LPBOR)
- Extended Watchdog Timer (WDT)
- In-Circuit Serial Programming[™] (ICSP[™]) via Two Pins
- In-Circuit Debug (ICD) via Two Pins
- Enhanced Low-Voltage Programming (LVP)
- Operating Voltage Range:
 - 1.8V to 3.6V
- Programmable Code Protection
- Self-Programmable under Software Control

Low-Power Features:

- Standby Current:
 - 30 nA @ 1.8V, typical
- Operating Current:
 - 75 μ A @ 1 MHz, 1.8V, typical
- Low-Power Watchdog Timer Current:
 - 500 nA @ 1.8V, typical

Peripheral Features:

- Up to 17 I/O Pins and One Input-only Pin:
 - High current sink/source for LED drivers
 - Individually programmable interrupt-on-change pins
 - Individually programmable weak pull-ups
- Timer0: 8-Bit Timer/Counter with 8-Bit Programmable Prescaler
- Enhanced Timer1:
 - 16-bit timer/counter with prescaler
 - External Gate Input mode
- Timer2 modules: 8-Bit Timer/Counter with 8-Bit Period Register, Prescaler and Postscaler
- Two PWM modules
- Two Analog-to-Digital Converters (ADC):
 - 10-bit resolution
 - Up to 17 channels
 - Simultaneous sampling on two ADCs
 - Connect multiple channels together for sampling
 - External conversion trigger
 - Flexible analog channel selection
 - Conversion during Sleep
 - Fixed Voltage Reference as channel
 - External pin as ADC positive reference
 - Temp sensor channel input
- Voltage Reference module:
 - Fixed Voltage Reference (FVR) with 1.024V and 2.048V output levels
- Hardware Capacitive Voltage Divider (CVD):
 - Double-sample conversions
 - Two sets of result registers
 - Inverted acquisition
 - 7-bit pre-charge timer
 - 7-bit acquisition timer
 - Two guard ring output drives
 - 30 pF adjustable sample and hold capacitor array
- Master Synchronous Serial Port (MSSP) with SPI and I²C[™] with:
 - 7-bit address masking
 - SMBus/PMBus[™] compatibility

PIC16LF1554/1559

- Enhanced Universal Synchronous Asynchronous Receiver Transmitter (EUSART):
 - RS-232, RS-485 and LIN compatible
 - Auto-Baud Detect
 - Auto-wake-up on start

PIC16LF1554/1559 Family Types

Device	Data Sheet Index	Program Memory Flash (words)	Data EEPROM (bytes)	SRAM (bytes)	I/Os ⁽¹⁾	10-bit ADC (ch) ⁽²⁾	Timers 8/16-Bit	EUSART	MSSP	PWM	Cap Touch Channels	Debug ⁽³⁾
PIC16LF1554	(A)	4096	0	256	12	11	2/1	1	1	2	11	I
PIC16LF1559	(A)	8192	0	512	18	17	2/1	1	1	2	17	I

Note 1: RA3 is input only.

2: 11/17 analog channels are connected to two ADC modules.

3: Debugging Methods: (I) – Integrated on Chip; (H) – available using Debug Header

Data Sheet Index: (Unshaded devices are described in this document)

A. DS40001761 [PIC16LF1554/1559 Data Sheet, 14/20-Pin, 8-Bit Flash Microcontrollers.](#)

Note: For other small form-factor package availability and marking information, please visit <http://www.microchip.com/packaging> or contact your local sales office.

Pin Diagrams

FIGURE 1: 14-PIN PDIP, SOIC, TSSOP

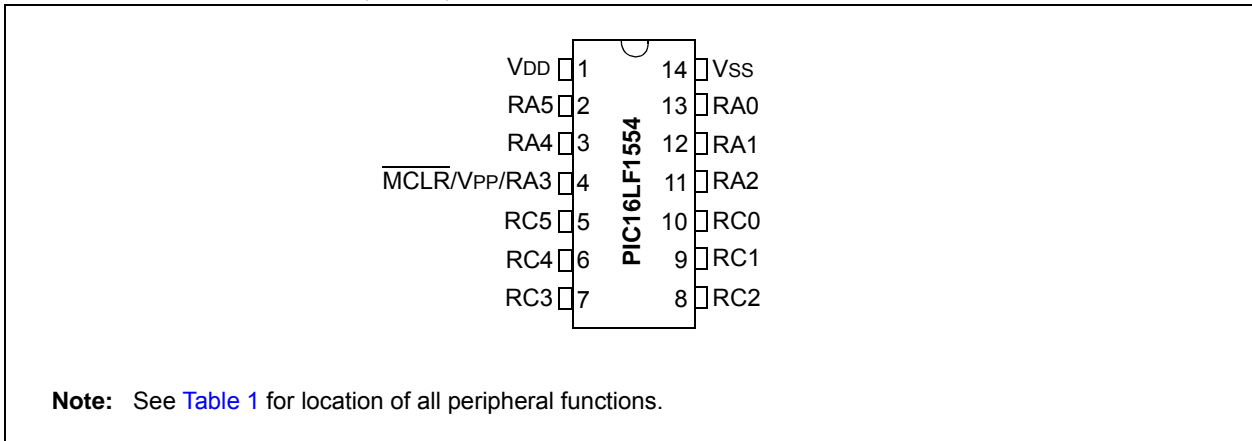

FIGURE 2: 16-PIN QFN

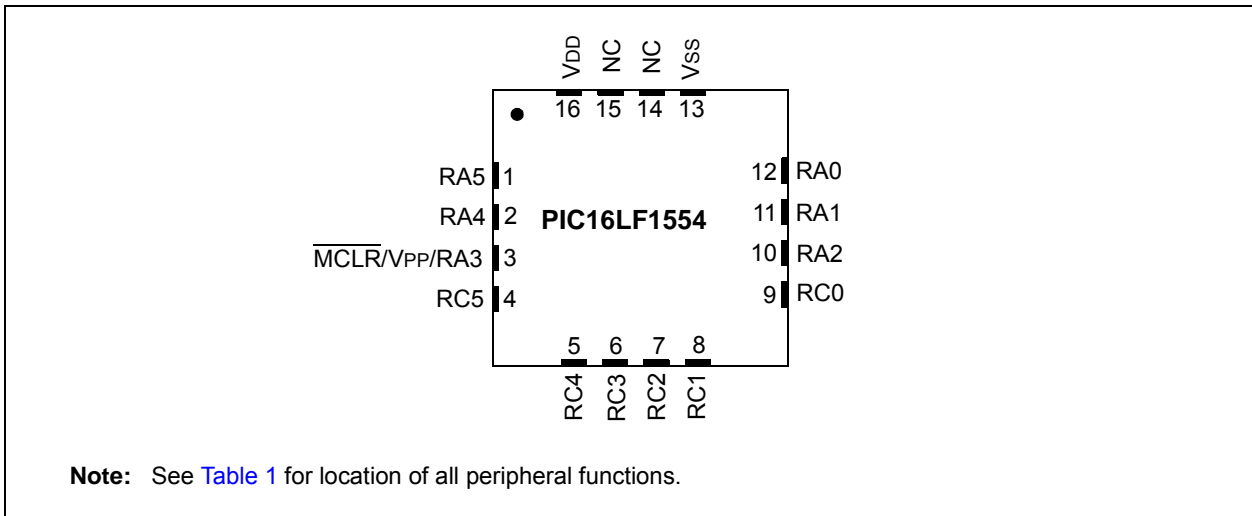
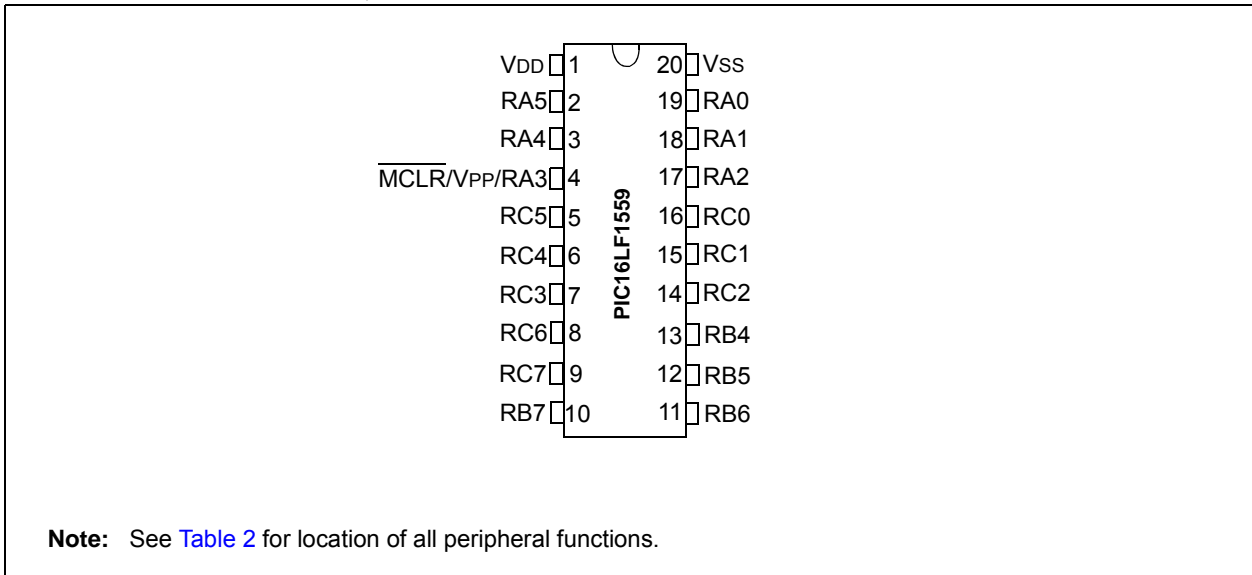
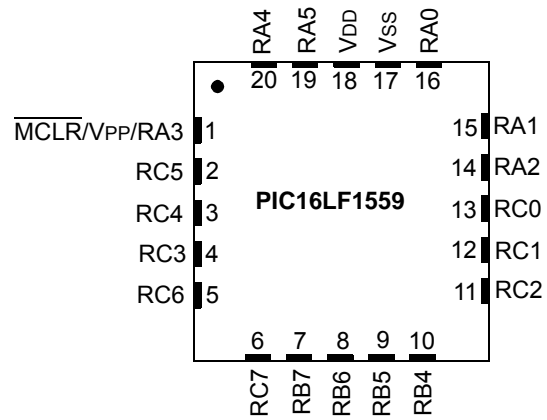

FIGURE 3: 20-PIN PDIP, SSOP



PIC16LF1554/1559

FIGURE 4: 20-PIN QFN (4x4)



Note: See [Table 2](#) for location of all peripheral functions.

PIC16LF1554/1559

Pin Allocation Tables

TABLE 1: 14-PIN AND 16-PIN ALLOCATION TABLE (PIC16LF1554)

I/O	14-Pin PDIP/SOIC/TSSOP	16-Pin QFN	ADC	Reference	Timers	PWM	EUSART	MSSP	Interrupt	Pull-up	Basic
RA0	13	12	AN0	—	—	—	—	—	IOC	Y	ICSPDAT/ ICDDAT
RA1	12	11	AN1	VREF+	—	—	—	—	IOC	Y	ICSPCLK ICDCLK
RA2	11	10	AN2	—	T0CKI	—	—	—	INT/ IOC	Y	—
RA3	4	3	—	—	—	—	—	$\overline{SS}^{(1)}$ SDA ⁽¹⁾ SDI ⁽¹⁾	IOC	Y	\overline{MCLR} VPP
RA4	3	2	AN10 ADTRIG	—	T1G	—	RX ⁽¹⁾ DT ⁽¹⁾	SDO ⁽¹⁾	IOC	Y	CLKOUT
RA5	2	1	AN20	—	T1CKI	—	—	—	IOC	Y	CLKIN
RC0	10	9	AN13	—	—	—	—	SCL SCK	—	Y	—
RC1	9	8	AN23	—	—	—	—	SDA ⁽¹⁾ SDI ⁽¹⁾	—	Y	—
RC2	8	7	AN12 AD1GRDB AD2GRDB ⁽¹⁾	—	—	PWM1	—	SDO ⁽¹⁾	—	Y	—
RC3	7	6	AN22 AD1GRDB ⁽¹⁾ AD2GRDB	—	—	PWM2	TX ⁽¹⁾ CK ⁽¹⁾	$\overline{SS}^{(1)}$	—	Y	—
RC4	6	5	AN11 AD1GRDA AD2GRDA ⁽¹⁾	—	—	—	TX ⁽¹⁾ CK ⁽¹⁾	—	—	Y	—
RC5	5	4	AN21 AD1GRDA ⁽¹⁾ AD2GRDA	—	—	—	RX ⁽¹⁾ DT ⁽¹⁾	—	—	Y	—
VDD	1	16	—	—	—	—	—	—	—	—	VDD
VSS	14	13	—	—	—	—	—	—	—	—	VSS

Note 1: Pin functions can be assigned to one of two pin locations via software.

PIC16LF1554/1559

TABLE 2: 20-PIN ALLOCATION TABLE (PIC16LF1559)

I/O	20-Pin PDIP/SSOP	20-Pin QFN	ADC	Reference	Timers	PWM	EUSART	MSSP	Interrupt	Pull-up	Basic
RA0	19	16	AN0	—	—	—	—	—	IOC	Y	ICSPDAT/ ICDDAT
RA1	18	15	AN1	VREF+	—	—	—	—	IOC	Y	ICSPCLK/ ICDCLK
RA2	17	14	AN2	—	T0CKI	—	—	—	INT/ IOC	Y	—
RA3	4	1	—	—	—	—	—	SDA ⁽¹⁾ SDI ⁽¹⁾ SS ⁽¹⁾	IOC	Y	MCLR VPP
RA4	3	20	AN10 ADTRIG	—	T1G	—	—	—	IOC	Y	CLKOUT
RA5	2	19	AN20	—	T1CKI	—	—	—	IOC	Y	CLKIN
RB4	13	10	AN26	—	—	—	—	SDA ⁽¹⁾ SDI ⁽¹⁾	IOC	Y	—
RB5	12	9	AN16	—	—	—	RX DT	—	IOC	Y	—
RB6	11	8	AN25	—	—	—	—	SCL SCK	IOC	Y	—
RB7	10	7	AN15	—	—	—	TX CK	—	IOC	Y	—
RC0	16	13	AN13	—	—	—	—	—	—	Y	—
RC1	15	12	AN23	—	—	—	—	—	—	Y	—
RC2	14	11	AN12 AD1GRDB AD2GRDB ⁽¹⁾	—	—	PWM1	—	—	—	Y	—
RC3	7	4	AN22 AD1GRDB ⁽¹⁾ AD2GRDB	—	—	PWM2	—	—	—	Y	—
RC4	6	3	AN11 AD1GRDA AD2GRDA ⁽¹⁾	—	—	—	—	—	—	Y	—
RC5	5	2	AN21 AD1GRDA ⁽¹⁾ AD2GRDA	—	—	—	—	—	—	Y	—
RC6	8	5	AN14	—	—	—	—	SS ⁽¹⁾	—	Y	—
RC7	9	6	AN24	—	—	—	—	SDO	—	Y	—
VDD	1	18	—	—	—	—	—	—	—	—	VDD
VSS	20	17	—	—	—	—	—	—	—	—	VSS

Note 1: Pin functions can be assigned to one of two pin locations via software.

Table of Contents

1.0	Device Overview	9
2.0	Enhanced Mid-Range CPU	16
3.0	Memory Organization	18
4.0	Device Configuration	52
5.0	Oscillator Module.....	56
6.0	Resets	64
7.0	Interrupts	72
8.0	Power-Down Mode (Sleep)	82
9.0	Watchdog Timer (WDT)	84
10.0	Flash Program Memory Control	88
11.0	I/O Ports	105
12.0	Interrupt-on-Change	118
13.0	Fixed Voltage Reference (FVR)	123
14.0	Temperature Indicator Module	125
15.0	Analog-to-Digital Converter (ADC) Module	127
16.0	Hardware Capacitive Voltage Divider (CVD) Module.....	141
17.0	Timer0 Module	164
18.0	Timer1 Module with Gate Control.....	167
19.0	Timer2 Module	178
20.0	Master Synchronous Serial Port (MSSP) Module	181
21.0	Enhanced Universal Synchronous Asynchronous Receiver Transmitter (EUSART).....	234
22.0	Pulse Width Modulation (PWM) Module.....	261
23.0	In-Circuit Serial Programming™ (ICSP™)	267
24.0	Instruction Set Summary	269
25.0	Electrical Specifications.....	283
26.0	DC and AC Characteristics Graphs and Charts	305
27.0	Development Support.....	306
28.0	Packaging Information.....	310
Appendix A:	Data Sheet Revision History.....	328
	The Microchip Web Site	329
	Customer Change Notification Service	329
	Customer Support.....	329
	Product Identification System	330

TO OUR VALUED CUSTOMERS

It is our intention to provide our valued customers with the best documentation possible to ensure successful use of your Microchip products. To this end, we will continue to improve our publications to better suit your needs. Our publications will be refined and enhanced as new volumes and updates are introduced.

If you have any questions or comments regarding this publication, please contact the Marketing Communications Department via E-mail at docerrors@microchip.com. We welcome your feedback.

Most Current Data Sheet

To obtain the most up-to-date version of this data sheet, please register at our Worldwide Web site at:

<http://www.microchip.com>

You can determine the version of a data sheet by examining its literature number found on the bottom outside corner of any page. The last character of the literature number is the version number, (e.g., DS30000000A is version A of document DS30000000).

Errata

An errata sheet, describing minor operational differences from the data sheet and recommended workarounds, may exist for current devices. As device/documentation issues become known to us, we will publish an errata sheet. The errata will specify the revision of silicon and revision of document to which it applies.

To determine if an errata sheet exists for a particular device, please check with one of the following:

- Microchip's Worldwide Web site; <http://www.microchip.com>
- Your local Microchip sales office (see last page)

When contacting a sales office, please specify which device, revision of silicon and data sheet (include literature number) you are using.

Customer Notification System

Register on our web site at www.microchip.com to receive the most current information on all of our products.

1.0 DEVICE OVERVIEW

The PIC16LF1554/1559 devices are described within this data sheet. The block diagram of these devices is shown in [Figure 1-1](#), the available peripherals are shown in [Table 1-1](#) and the pinout descriptions are shown in [Table 1-2](#) and [Table 1-3](#).

TABLE 1-1: DEVICE PERIPHERAL SUMMARY

Peripheral	PIC16LF1554	PIC16LF1559
Analog-to-Digital Converter (ADC)		
	ADC1	• •
	ADC2	• •
Hardware Capacitive Voltage Divider (CVD)		
Enhanced Universal Synchronous/Asynchronous Receiver/Transmitter (EUSART)		
Fixed Voltage Reference (FVR)		
Temperature Indicator		
Master Synchronous Serial Ports		
	MSSP	• •
PWM Modules		
	PWM1	• •
	PWM2	• •
Timers		
	Timer0	• •
	Timer1	• •
	Timer2	• •

PIC16LF1554/1559

FIGURE 1-1: PIC16LF1554/1559 BLOCK DIAGRAM^(1,2)

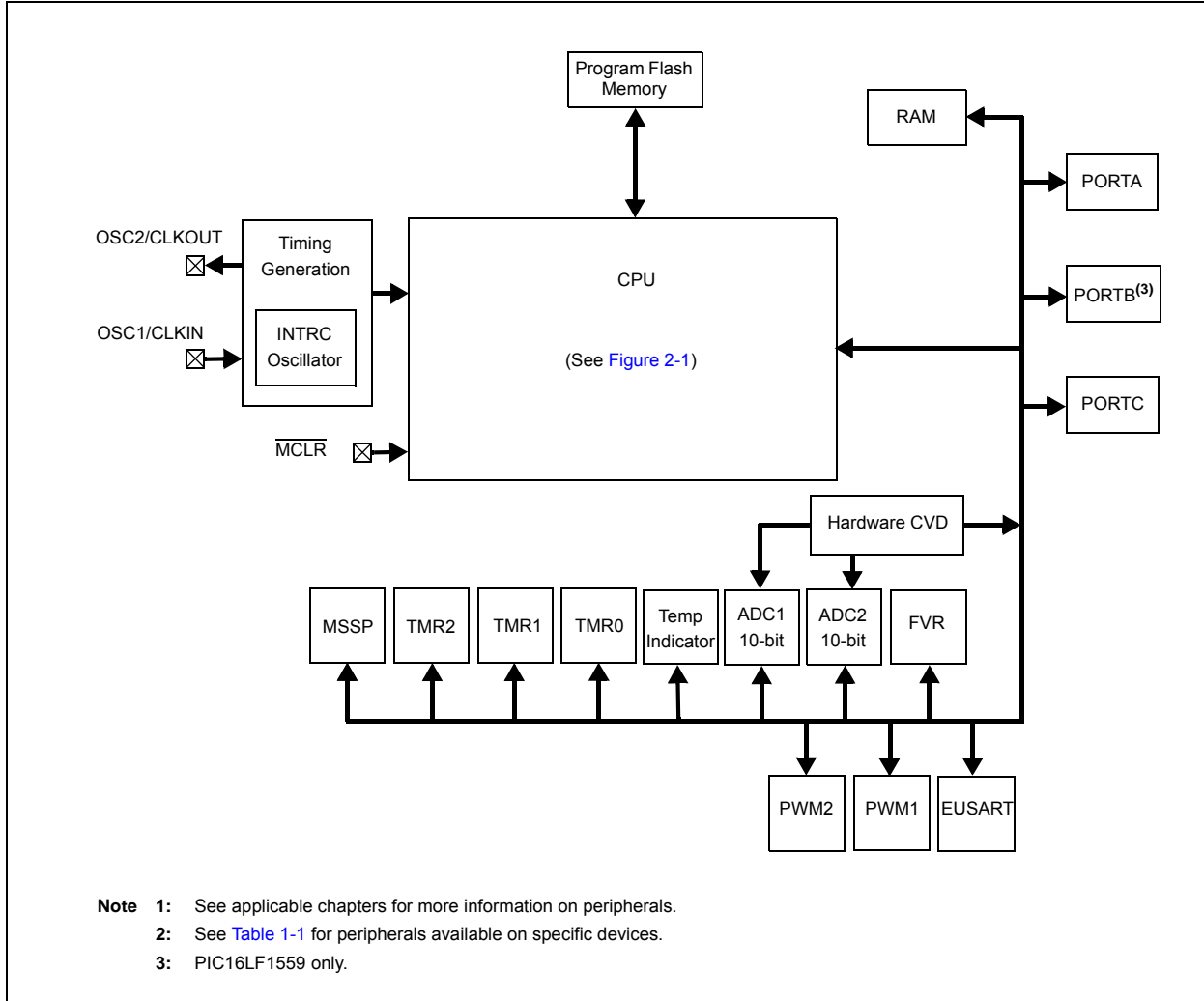

TABLE 1-2: PIC16LF1554 PINOUT DESCRIPTION

Name	Function	Input Type	Output Type	Description
RA0/AN0/ISCPDAT/ICDDAT	RA0	TTL	CMOS	General Purpose I/O
	AN0	AN	—	ADC Channel Input
	ICSPDAT	ST	CMOS	ICSP™ Data I/O
	ICDDAT	ST	CMOS	In-Circuit Debug Data
RA1/AN1/VREF+/ICSPCLK/ICDCLK	RA1	TTL	CMOS	General Purpose I/O
	AN1	AN	—	ADC Channel Input
	VREF+	AN	—	ADC Positive Voltage Reference Input
	ICSPCLK	ST	CMOS	ICSP Programming Clock
	ICDCLK	ST	CMOS	In-Circuit Debug Clock
RA2/AN2/TOCKI/INT/	RA2	TTL	CMOS	General Purpose I/O
	AN2	AN	—	ADC Channel Input
	TOCKI	ST	—	Timer0 Clock Input
	INT	ST	—	External Interrupt
RA3/VPP/ $\overline{SS}^{(1)}$ / $\overline{SDA}^{(1)}$ / $\overline{SDI}^{(1)}$ / \overline{MCLR}	RA3	TTL	CMOS	General Purpose Input with IOC and WPU
	Vpp	HV	—	Programming Voltage
	\overline{SS}	ST	—	Slave Select Input
	SDA	I ² C™	OD	I ² C™ Data Input/Output
	SDI	CMOS	—	SPI Data Input
	\overline{MCLR}	ST	—	Master Clear with Internal Pull-up
RA4/AN10/ADTRIG/CLKOUT/ $\overline{RX}^{(1)}$ / $\overline{DT}^{(1)}$ / $\overline{SDO}^{(1)}$ /T1G	RA4	TTL	CMOS	General Purpose I/O
	AN10	AN	—	ADC Channel Input
	ADTRIG	ST	—	ADC Conversion Trigger Input
	CLKOUT	—	CMOS	Fosc/4 Output
	RX	ST	—	USART Asynchronous Input
	DT	ST	CMOS	USART Synchronous Data
	SDO	—	CMOS	SPI Data Output
	T1G	ST	—	Timer1 Gate Input
RA5/AN20/CLKIN/T1CKI	RA5	TTL	CMOS	General Purpose I/O
	AN20	AN	—	ADC Channel Input
	CLKIN	CMOS	—	External Clock Input (EC mode)
	T1CKI	ST	—	Timer1 Clock Input
RC0/AN13/SCL/SCK	RC0	TTL	CMOS	General Purpose I/O
	AN13	AN	—	ADC Channel Input
	SCL	I ² C	OD	I ² C Clock
	SCK	ST	CMOS	SPI Clock

Legend: AN = Analog input or output CMOS = CMOS compatible input or output OD = Open Drain
TTL = TTL compatible input ST = Schmitt Trigger input with CMOS levels I²C = Schmitt Trigger input with I²C levels
HV = High Voltage XTAL = Crystal

Note 1: Alternate pin function selected with the APFCON (Register 11-1) register.

PIC16LF1554/1559

TABLE 1-2: PIC16LF1554 PINOUT DESCRIPTION (CONTINUED)

Name	Function	Input Type	Output Type	Description
RC1/AN23/SDA ⁽¹⁾ /SDI ⁽¹⁾	RC1	TTL	CMOS	General Purpose I/O
	AN23	AN	—	ADC Channel Input
	SDA	I ² C	OD	I ² C Data Input/Output
	SDI	CMOS	—	SPI Data Input
RC2/AN12/AD1GRDB ⁽¹⁾ /AD2GRDB ⁽¹⁾ /PWM1/SDO ⁽¹⁾	RC2	TTL	CMOS	General Purpose I/O
	AN12	AN	—	ADC Channel Input
	AD1GRDB	—	CMOS	ADC1 Guard Ring Output B
	AD2GRDB	—	CMOS	ADC2 Guard Ring Output B
	PWM1	—	CMOS	PWM Output
	SDO	—	CMOS	SPI Data Output
RC3/AN22/AD1GRDB ⁽¹⁾ /AD2GRDB ⁽¹⁾ /PWM2/TX ⁽¹⁾ /CK ⁽¹⁾ / \overline{SS} ⁽¹⁾	RC3	TTL	CMOS	General Purpose I/O
	AN22	AN	—	ADC Channel Input
	AD1GRDB	—	CMOS	ADC1 Guard Ring Output B
	AD2GRDB	—	CMOS	ADC2 Guard Ring Output B
	PWM2	—	CMOS	PWM Output
	TX	—	CMOS	USART Asynchronous Transmit
	CK	ST	CMOS	USART Synchronous Clock
	\overline{SS}	ST	—	Slave Select Input
RC4/AN11/AD1GRDA ⁽¹⁾ /AD2GRDA ⁽¹⁾ /TX ⁽¹⁾ /CK ⁽¹⁾	RC3	TTL	CMOS	General Purpose I/O
	AN11	AN	—	ADC Channel Input
	AD1GRDA	—	CMOS	ADC1 Guard Ring Output B
	AD2GRDA	—	CMOS	ADC2 Guard Ring Output B
	TX	—	CMOS	USART Asynchronous Transmit
	CK	ST	CMOS	USART Synchronous Clock
RC5/AN21/AD1GRDA ⁽¹⁾ /AD2GRDA ⁽¹⁾ /RX ⁽¹⁾ /DT ⁽¹⁾	RC5	TTL	CMOS	General Purpose I/O
	AN21	AN	—	ADC Channel Input
	AD1GRDA	—	CMOS	ADC1 Guard Ring Output B
	AD2GRDA	—	CMOS	ADC2 Guard Ring Output B
	RX	ST	—	USART Asynchronous Input
	DT	ST	CMOS	USART Synchronous Data

Legend: AN = Analog input or output CMOS = CMOS compatible input or output OD = Open Drain
TTL = TTL compatible input ST = Schmitt Trigger input with CMOS levels I²C = Schmitt Trigger input with I²C levels
HV = High Voltage XTAL = Crystal

Note 1: Alternate pin function selected with the APFCON (Register 11-1) register.

TABLE 1-3: PIC16LF1559 PINOUT DESCRIPTION

Name	Function	Input Type	Output Type	Description
RA0/AN0/ICSPDAT/ICDDAT	RA0	TTL	CMOS	General Purpose I/O
	AN0	AN	—	ADC Channel Input
	ICSPDAT	ST	CMOS	ICSP™ Data I/O
	ICDDAT	ST	CMOS	In-Circuit Debug Data
RA1/AN1/VREF+/ICSPCLK/ICDCLK	RA1	TTL	CMOS	General Purpose I/O
	AN1	AN	—	ADC Channel Input
	VREF+	AN	—	ADC Positive Voltage Reference Input
	ICSPCLK	ST	CMOS	ICSP Programming Clock
	ICDCLK	ST	CMOS	In-Circuit Debug Clock
RA2/AN2/TOCKI/INT	RA2	TTL	CMOS	General Purpose I/O
	AN2	AN	—	ADC Channel Input
	TOCKI	ST	—	Timer0 Clock Input
	INT	ST	—	External Interrupt
RA3/VPP/SS ⁽¹⁾ /SDA ⁽¹⁾ /SDI ⁽¹⁾ /MCLR	RA3	TTL	CMOS	General Purpose Input with IOC and WPU
	Vpp	HV	—	Programming Voltage
	SS	ST	—	Slave Select Input
	SDA	I ² C™	OD	I ² C™ Data Input/Output
	SDI	CMOS	—	SPI Data Input
	MCLR	ST	—	Master Clear with Internal Pull-up
RA4/AN10/ADTRIG/CLKOUT/T1G	RA4	TTL	CMOS	General Purpose I/O
	AN10	AN	—	ADC Channel Input
	ADTRIG	ST	—	ADC Conversion Trigger Input
	CLKOUT	—	CMOS	Fosc/4 Output
	T1G	ST	—	Timer1 Gate input.
RA5/AN20/CLKIN/T1CKI	RA5	TTL	CMOS	General Purpose I/O
	AN20	AN	—	ADC Channel Input
	CLKIN	CMOS	—	External Clock Input (EC mode)
	T1CKI	ST	—	Timer1 clock Input
RB4/AN26/SDA ⁽¹⁾ /SDI ⁽¹⁾	RB4	TTL	CMOS	General Purpose I/O
	AN26	AN	—	ADC Channel Input
	SDA	I ² C	OD	I ² C Data Input/Output
	SDI	CMOS	—	SPI Data Input

Legend: AN = Analog input or output CMOS = CMOS compatible input or output OD = Open Drain
TTL = TTL compatible input ST = Schmitt Trigger input with CMOS levels I²C = Schmitt Trigger input with I²C levels
HV = High Voltage XTAL = Crystal

Note 1: Alternate pin function selected with the APFCON (Register 11-1) register.

PIC16LF1554/1559

TABLE 1-3: PIC16LF1559 PINOUT DESCRIPTION (CONTINUED)

Name	Function	Input Type	Output Type	Description
RB5/AN16/RX ⁽¹⁾ /DT ⁽¹⁾	RB5	TTL	CMOS	General Purpose I/O
	AN16	AN	—	ADC Channel Input
	RX	ST	—	USART Asynchronous Input
	DT	ST	CMOS	USART Synchronous Data
RB6/AN25/SCL/SCK	RB6	TTL	CMOS	General Purpose I/O
	AN25	AN	—	ADC Channel Input
	SCL	I ² C	OD	I ² C Clock
	SCK	ST	CMOS	SPI Clock
RB7/AN15/TX/CK	RB7	TTL	CMOS	General Purpose I/O
	AN15	AN	—	ADC Channel Input
	TX	—	CMOS	USART Asynchronous Transmit
	CK	ST	CMOS	USART Synchronous Clock
RC0/AN13	RC0	TTL	CMOS	General Purpose I/O
	AN13	AN	—	ADC Channel Input
RC1/AN23	RC1	TTL	CMOS	General Purpose I/O
	AN23	AN	—	ADC Channel Input
RC2/AN12/AD1GRDB ⁽¹⁾ /AD2GRDB ⁽¹⁾ /PWM1	RC2	TTL	CMOS	General Purpose I/O
	AN12	AN	—	ADC Channel Input
	AD1GRDB	—	CMOS	ADC1 Guard Ring Output B
	AD2GRDB	—	CMOS	ADC2 Guard Ring Output B
	PWM1	—	CMOS	PWM Output
RC3/AN22/AD1GRDB ⁽¹⁾ /AD2GRDB ⁽¹⁾ /PWM2	RC3	TTL	CMOS	General Purpose I/O
	AN22	AN	—	ADC Channel Input
	AD1GRDB	—	CMOS	ADC1 Guard Ring Output B
	AD2GRDB	—	CMOS	ADC2 Guard Ring Output B
	PWM2	—	CMOS	PWM Output
RC4/AN11/AD1GRDA ⁽¹⁾ /AD2GRDA ⁽¹⁾	RC4	TTL	CMOS	General Purpose I/O
	AN11	AN	—	ADC Channel Input
	AD1GRDA	—	CMOS	ADC1 Guard Ring Output B
	AD2GRDA	—	CMOS	ADC2 Guard Ring Output B
RC5/AN21/AD1GRDA ⁽¹⁾ /AD2GRDA ⁽¹⁾	RC5	TTL	CMOS	General Purpose I/O
	AN21	AN	—	ADC Channel Input
	AD1GRDA	—	CMOS	ADC1 Guard Ring Output B
	AD2GRDA	—	CMOS	ADC2 Guard Ring Output B

Legend: AN = Analog input or output CMOS = CMOS compatible input or output OD = Open Drain
TTL = TTL compatible input ST = Schmitt Trigger input with CMOS levels I²C = Schmitt Trigger input with I²C levels
HV = High Voltage XTAL = Crystal

Note 1: Alternate pin function selected with the APFCON (Register 11-1) register.

TABLE 1-3: PIC16LF1559 PINOUT DESCRIPTION (CONTINUED)

Name	Function	Input Type	Output Type	Description
RC6/AN14/ $\overline{SS}^{(1)}$	RC6	TTL	CMOS	General Purpose I/O
	AN14	AN	—	ADC Channel Input
	\overline{SS}	ST	—	Slave Select Input
RC7/AN24/SDO	RC7	TTL	CMOS	General Purpose I/O
	AN24	AN	—	ADC Channel Input
	SDO	—	CMOS	SPI Data Output

Legend: AN = Analog input or output CMOS = CMOS compatible input or output OD = Open Drain
 TTL = TTL compatible input ST = Schmitt Trigger input with CMOS levels I²C = Schmitt Trigger input with I²C levels
 HV = High Voltage XTAL = Crystal

Note 1: Alternate pin function selected with the APFCON (Register 11-1) register.

PIC16LF1554/1559

2.0 ENHANCED MID-RANGE CPU

This family of devices contain an enhanced mid-range 8-bit CPU core. The CPU has 49 instructions. Interrupt capability includes automatic context saving. The hardware stack is 16 levels deep and has Overflow and Underflow Reset capability. Direct, Indirect, and Relative Addressing modes are available. Two File Select Registers (FSRs) provide the ability to read program and data memory.

- Automatic Interrupt Context Saving
- 16-level Stack with Overflow and Underflow
- File Select Registers
- Instruction Set

FIGURE 2-1: CORE BLOCK DIAGRAM

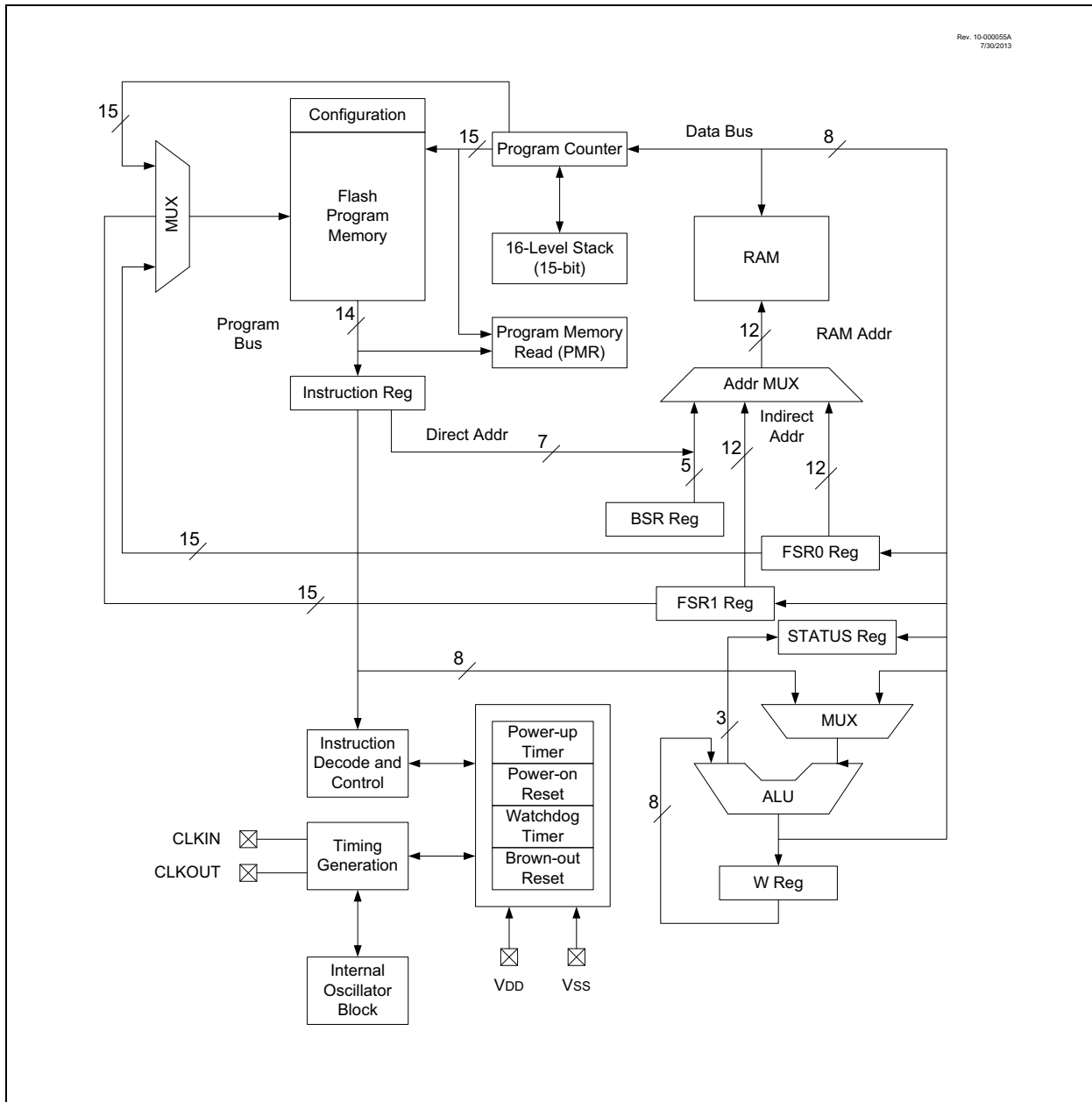

2.1 Automatic Interrupt Context Saving

During interrupts, certain registers are automatically saved in shadow registers and restored when returning from the interrupt. This saves stack space and user code. See [Section 7.5 “Automatic Context Saving”](#), for more information.

2.2 16-Level Stack with Overflow and Underflow

These devices have a hardware stack memory 15 bits wide and 16 words deep. A Stack Overflow or Underflow will set the appropriate bit (STKOVF or STKUNF) in the PCON register, and if enabled, will cause a software Reset. See section [Section 3.4 “Stack”](#) for more details.

2.3 File Select Registers

There are two 16-bit File Select Registers (FSR). FSRs can access all file registers and program memory, which allows one Data Pointer for all memory. When an FSR points to program memory, there is one additional instruction cycle in instructions using INDF to allow the data to be fetched. General purpose memory can now also be addressed linearly, providing the ability to access contiguous data larger than 80 bytes. There are also new instructions to support the FSRs. See [Section 3.5 “Indirect Addressing”](#) for more details.

2.4 Instruction Set

There are 49 instructions for the enhanced mid-range CPU to support the features of the CPU. See [Section 24.0 “Instruction Set Summary”](#) for more details.

PIC16LF1554/1559

3.0 MEMORY ORGANIZATION

These devices contain the following types of memory:

- Program Memory
 - Configuration Words
 - Device ID
 - User ID
 - Flash Program Memory
- Data Memory
 - Core Registers
 - Special Function Registers
 - General Purpose RAM
 - Common RAM

The following features are associated with access and control of program memory and data memory:

- PCL and PCLATH
- Stack
- Indirect Addressing

3.1 Program Memory Organization

The enhanced mid-range core has a 15-bit program counter capable of addressing a 32K x 14 program memory space. [Table 3-1](#) shows the memory sizes implemented. Accessing a location above these boundaries will cause a wrap-around within the implemented memory space. The Reset vector is at 0000h and the interrupt vector is at 0004h (see [Figure 3-1](#)).

TABLE 3-1: DEVICE SIZES AND ADDRESSES

Device	Program Memory Space (Words)	Last Program Memory Address	High-Endurance Flash Memory Address Range ⁽¹⁾
PIC16LF1554	4,096	0FFFh	0F80h-0FFFh
PIC16LF1559	8,192	1FFFh	1F80h-1FFFh

Note 1: High-endurance Flash applies to low byte of each address in the range.

FIGURE 3-1: PROGRAM MEMORY MAP AND STACK FOR PIC16LF1554

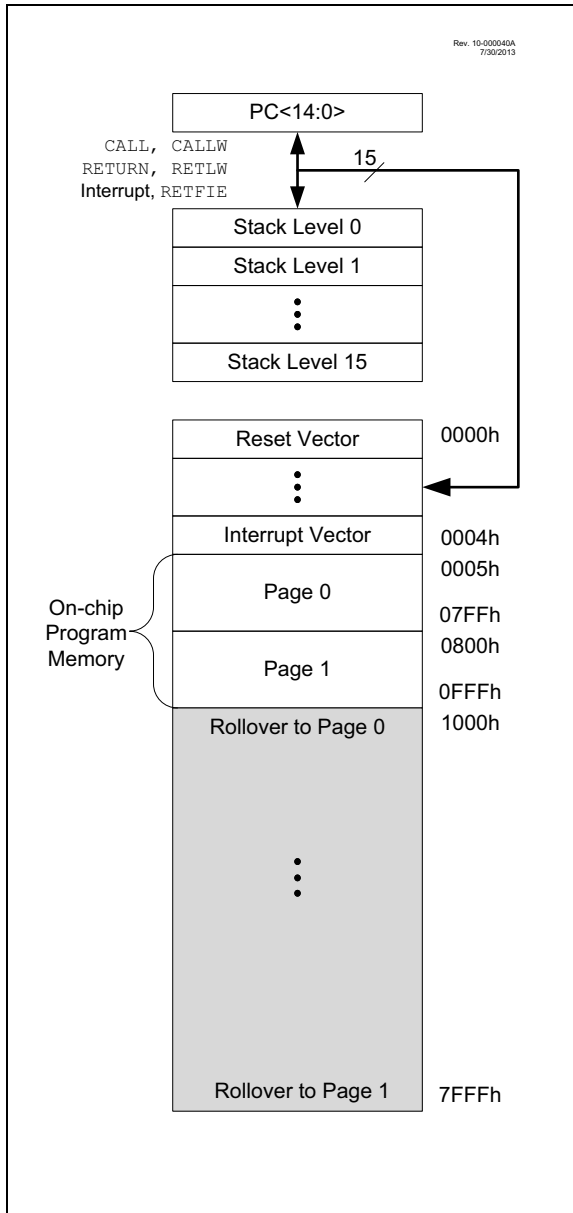
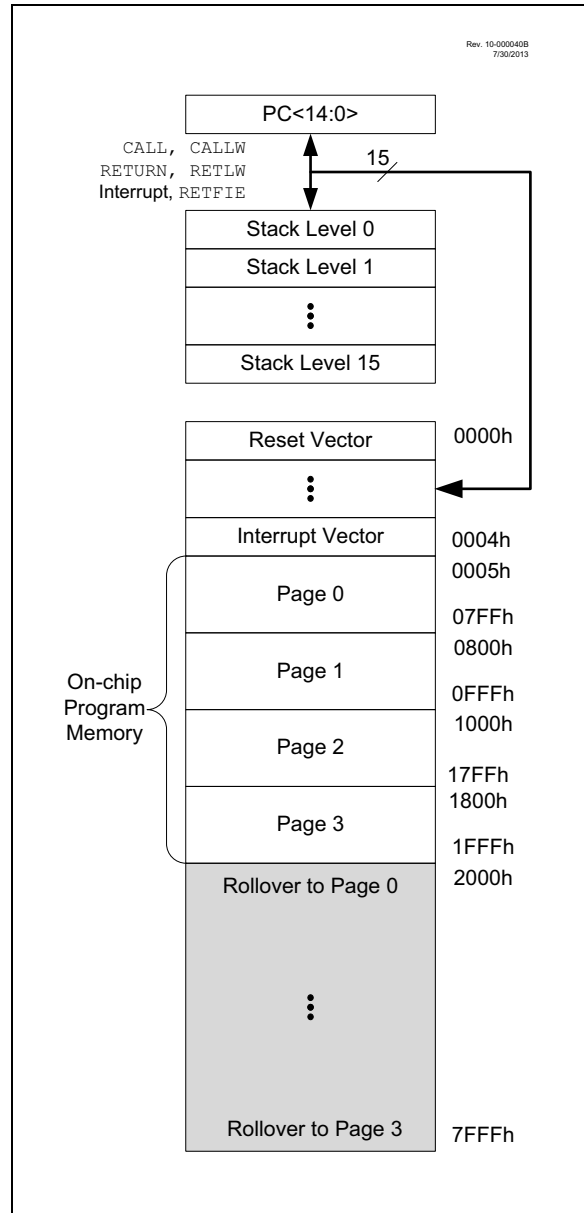

FIGURE 3-2: PROGRAM MEMORY MAP AND STACK FOR PIC16LF1559



PIC16LF1554/1559

3.1.1 READING PROGRAM MEMORY AS DATA

There are two methods of accessing constants in program memory. The first method is to use tables of RETLW instructions. The second method is to set an FSR to point to the program memory.

3.1.1.1 RETLW Instruction

The RETLW instruction can be used to provide access to tables of constants. The recommended way to create such a table is shown in [Example 3-1](#).

EXAMPLE 3-1: RETLW INSTRUCTION

```
constants
    BRW          ;Add Index in W to
                ;program counter to
                ;select data
    RETLW DATA0 ;Index0 data
    RETLW DATA1 ;Index1 data
    RETLW DATA2
    RETLW DATA3

my_function
    ;... LOTS OF CODE...
    MOVLW      DATA_INDEX
    call constants
    ;... THE CONSTANT IS IN W
```

The BRW instruction makes this type of table very simple to implement. If your code must remain portable with previous generations of microcontrollers, then the BRW instruction is not available so the older table read method must be used.

3.1.1.2 Indirect Read with FSR

The program memory can be accessed as data by setting bit 7 of the FSRxH register and reading the matching INDFx register. The MOVLW instruction will place the lower eight bits of the addressed word in the W register. Writes to the program memory cannot be performed via the INDF registers. Instructions that access the program memory via the FSR require one extra instruction cycle to complete. [Example 3-2](#) demonstrates accessing the program memory via an FSR.

The HIGH operator will set bit 7 if a label points to a location in program memory.

EXAMPLE 3-2: ACCESSING PROGRAM MEMORY VIA FSR

```
constants
    RETLW DATA0 ;Index0 data
    RETLW DATA1 ;Index1 data
    RETLW DATA2
    RETLW DATA3

my_function
    ;... LOTS OF CODE...
    MOVLW LOW constants
    MOVWF FSR1L
    MOVLW HIGH constants
    MOVWF FSR1H
    MOVLW 0[FSR1]
    ;THE PROGRAM MEMORY IS IN W
```

3.2 Data Memory Organization

The data memory is partitioned in 32 memory banks with 128 bytes in a bank. Each bank consists of (Figure 3-3):

- 12 core registers
- 20 Special Function Registers (SFR)
- Up to 80 bytes of General Purpose RAM (GPR)
- 16 bytes of common RAM

The active bank is selected by writing the bank number into the Bank Select Register (BSR). Unimplemented memory will read as '0'. All data memory can be accessed either directly (via instructions that use the file registers) or indirectly via the two File Select Registers (FSR). See Section 3.5 “Indirect Addressing” for more information.

Data memory uses a 12-bit address. The upper five bits of the address define the Bank address and the lower seven bits select the registers/RAM in that bank.

3.2.1 CORE REGISTERS

The core registers contain the registers that directly affect the basic operation. The core registers occupy the first 12 addresses of every data memory bank (addresses x00h/x08h through x0Bh/x8Bh). These registers are listed below in Table 3-2. For detailed information, see Table 3-8.

TABLE 3-2: CORE REGISTERS

Addresses	BANKx
x00h or x80h	INDF0
x01h or x81h	INDF1
x02h or x82h	PCL
x03h or x83h	STATUS
x04h or x84h	FSR0L
x05h or x85h	FSR0H
x06h or x86h	FSR1L
x07h or x87h	FSR1H
x08h or x88h	BSR
x09h or x89h	WREG
x0Ah or x8Ah	PCLATH
x0Bh or x8Bh	INTCON

PIC16LF1554/1559

3.2.1.1 STATUS Register

The STATUS register, shown in [Register 3-1](#), contains:

- the arithmetic status of the ALU
- the Reset status

The STATUS register can be the destination for any instruction, like any other register. If the STATUS register is the destination for an instruction that affects the Z, DC or C bits, then the write to these three bits is disabled. These bits are set or cleared according to the device logic. Furthermore, the $\overline{\text{TO}}$ and $\overline{\text{PD}}$ bits are not writable. Therefore, the result of an instruction with the STATUS register as destination may be different than intended.

For example, `CLRF STATUS` will clear the upper three bits and set the Z bit. This leaves the STATUS register as '000u u1uu' (where u = unchanged).

It is recommended, therefore, that only `BCF`, `BSF`, `SWAPF` and `MOVWF` instructions are used to alter the STATUS register, because these instructions do not affect any Status bits. For other instructions not affecting any Status bits (refer to [Section 24.0 "Instruction Set Summary"](#)).

Note 1: The C and DC bits operate as Borrow and Digit Borrow out bits, respectively, in subtraction.

REGISTER 3-1: STATUS: STATUS REGISTER

U-0	U-0	U-0	R-1/q	R-1/q	R/W-0/u	R/W-0/u	R/W-0/u	
—	—	—	$\overline{\text{TO}}$	$\overline{\text{PD}}$	Z	DC ⁽¹⁾	C ⁽¹⁾	
bit 7								bit 0

Legend:

R = Readable bit	W = Writable bit	U = Unimplemented bit, read as '0'
u = Bit is unchanged	x = Bit is unknown	-n/n = Value at POR and BOR/Value at all other Resets
'1' = Bit is set	'0' = Bit is cleared	q = Value depends on condition

- bit 7-5 **Unimplemented:** Read as '0'
- bit 4 **$\overline{\text{TO}}$:** Time-Out bit
1 = After power-up, `CLRWDT` instruction or `SLEEP` instruction
0 = A WDT time-out occurred
- bit 3 **$\overline{\text{PD}}$:** Power-Down bit
1 = After power-up or by the `CLRWDT` instruction
0 = By execution of the `SLEEP` instruction
- bit 2 **Z:** Zero bit
1 = The result of an arithmetic or logic operation is zero
0 = The result of an arithmetic or logic operation is not zero
- bit 1 **DC:** Digit Carry/Digit Borrow bit (`ADDWF`, `ADDLW`, `SUBLW`, `SUBWF` instructions)⁽¹⁾
1 = A carry-out from the 4th low-order bit of the result occurred
0 = No carry-out from the 4th low-order bit of the result
- bit 0 **C:** Carry/Borrow bit⁽¹⁾ (`ADDWF`, `ADDLW`, `SUBLW`, `SUBWF` instructions)⁽¹⁾
1 = A carry-out from the Most Significant bit of the result occurred
0 = No carry-out from the Most Significant bit of the result occurred

Note 1: For Borrow, the polarity is reversed. A subtraction is executed by adding the two's complement of the second operand. For rotate (`RRF`, `RLF`) instructions, this bit is loaded with either the high-order or low-order bit of the source register.

3.2.2 SPECIAL FUNCTION REGISTER

The Special Function Registers are registers used by the application to control the desired operation of peripheral functions in the device. The Special Function Registers occupy the 20 bytes after the core registers of every data memory bank (addresses x0Ch/x8Ch through x1Fh/x9Fh). The registers associated with the operation of the peripherals are described in the appropriate peripheral chapter of this data sheet.

3.2.3 GENERAL PURPOSE RAM

There are up to 80 bytes of GPR in each data memory bank. The Special Function Registers occupy the 20 bytes after the core registers of every data memory bank (addresses x0Ch/x8Ch through x1Fh/x9Fh).

3.2.3.1 Linear Access to GPR

The general purpose RAM can be accessed in a non-banked method via the FSRs. This can simplify access to large memory structures. See [Section 3.5.2 “Linear Data Memory”](#) for more information.

3.2.4 COMMON RAM

There are 16 bytes of common RAM accessible from all banks.

3.2.5 DEVICE MEMORY MAPS

The memory maps for PIC16LF1554/1559 are as shown in [Table 3-3](#) through [Table 3-7](#).

FIGURE 3-3: BANKED MEMORY PARTITIONING

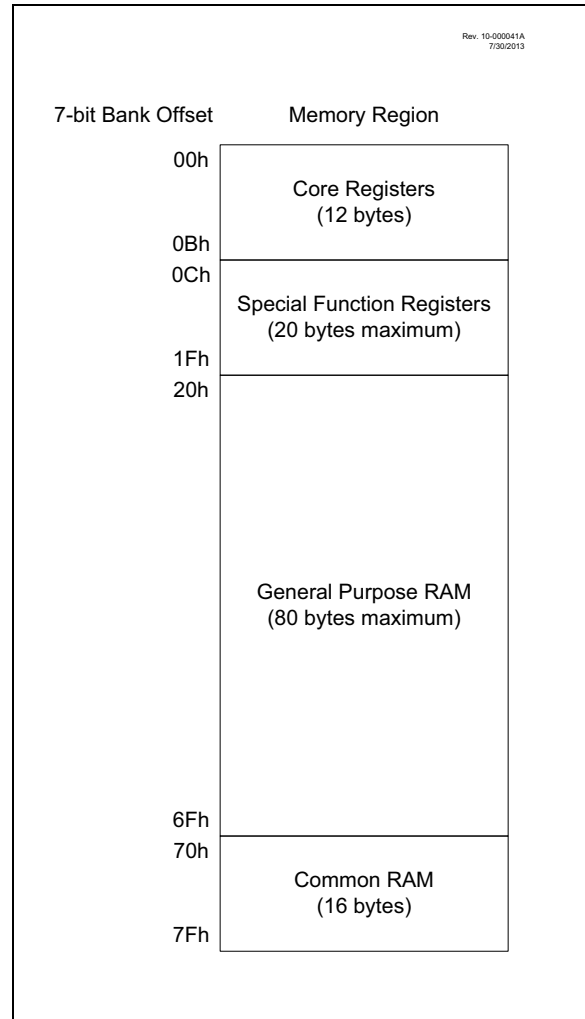

TABLE 3-3: PIC16LF1554 MEMORY MAP, BANKS 0-7

BANK 0		BANK 1		BANK 2		BANK 3		BANK 4		BANK 5		BANK 6		BANK 7	
000h	INDF0	080h	INDF0	100h	INDF0	180h	INDF0	200h	INDF0	280h	INDF0	300h	INDF0	380h	INDF0
001h	INDF1	081h	INDF1	101h	INDF1	181h	INDF1	201h	INDF1	281h	INDF1	301h	INDF1	381h	INDF1
002h	PCL	082h	PCL	102h	PCL	182h	PCL	202h	PCL	282h	PCL	302h	PCL	382h	PCL
003h	STATUS	083h	STATUS	103h	STATUS	183h	STATUS	203h	STATUS	283h	STATUS	303h	STATUS	383h	STATUS
004h	FSR0L	084h	FSR0L	104h	FSR0L	184h	FSR0L	204h	FSR0L	284h	FSR0L	304h	FSR0L	384h	FSR0L
005h	FSR0H	085h	FSR0H	105h	FSR0H	185h	FSR0H	205h	FSR0H	285h	FSR0H	305h	FSR0H	385h	FSR0H
006h	FSR1L	086h	FSR1L	106h	FSR1L	186h	FSR1L	206h	FSR1L	286h	FSR1L	306h	FSR1L	386h	FSR1L
007h	FSR1H	087h	FSR1H	107h	FSR1H	187h	FSR1H	207h	FSR1H	287h	FSR1H	307h	FSR1H	387h	FSR1H
008h	BSR	088h	BSR	108h	BSR	188h	BSR	208h	BSR	288h	BSR	308h	BSR	388h	BSR
009h	WREG	089h	WREG	109h	WREG	189h	WREG	209h	WREG	289h	WREG	309h	WREG	389h	WREG
00Ah	PCLATH	08Ah	PCLATH	10Ah	PCLATH	18Ah	PCLATH	20Ah	PCLATH	28Ah	PCLATH	30Ah	PCLATH	38Ah	PCLATH
00Bh	INTCON	08Bh	INTCON	10Bh	INTCON	18Bh	INTCON	20Bh	INTCON	28Bh	INTCON	30Bh	INTCON	38Bh	INTCON
00Ch	PORTA	08Ch	TRISA	10Ch	LATA	18Ch	ANSELA	20Ch	WPUA	28Ch	—	30Ch	—	38Ch	—
00Dh	—	08Dh	—	10Dh	—	18Dh	—	20Dh	—	28Dh	—	30Dh	—	38Dh	—
00Eh	PORTC	08Eh	TRISC	10Eh	LATC	18Eh	ANSELC	20Eh	—	28Eh	—	30Eh	—	38Eh	—
00Fh	—	08Fh	—	10Fh	—	18Fh	—	20Fh	—	28Fh	—	30Fh	—	38Fh	—
010h	—	090h	—	110h	—	190h	—	210h	—	290h	—	310h	—	390h	—
011h	PIR1	091h	PIE1	111h	—	191h	PMADRL	211h	SSPBUF	291h	—	311h	—	391h	IOCAP
012h	PIR2	092h	PIE2	112h	—	192h	PMADRH	212h	SSPADD	292h	—	312h	—	392h	IOCAN
013h	—	093h	—	113h	—	193h	PMDATL	213h	SSPMSK	293h	—	313h	—	393h	IOCAF
014h	—	094h	—	114h	—	194h	PMDATH	214h	SSPSTAT	294h	—	314h	—	394h	—
015h	TMR0	095h	OPTION	115h	—	195h	PMCON1	215h	SSPCON1	295h	—	315h	—	395h	—
016h	TMR1L	096h	PCON	116h	BORCON	196h	PMCON2	216h	SSPCON2	296h	—	316h	—	396h	—
017h	TMR1H	097h	WDTCON	117h	FVRCON	197h	—	217h	SSPCON3	297h	—	317h	—	397h	—
018h	T1CON	098h	—	118h	—	198h	—	218h	—	298h	—	318h	—	398h	—
019h	T1GCON	099h	OSCCON	119h	—	199h	RCREG	219h	—	299h	—	319h	—	399h	—
01Ah	TMR2	09Ah	OSCSTAT	11Ah	—	19Ah	TXREG	21Ah	—	29Ah	—	31Ah	—	39Ah	—
01Bh	PR2	09Bh	ADRESL/ AD1RES0L ⁽¹⁾	11Bh	—	19Bh	SPBRGL	21Bh	—	29Bh	—	31Bh	—	39Bh	—
01Ch	T2CON	09Ch	ADRESH/ AD1RES0H ⁽¹⁾	11Ch	—	19Ch	SPBRGH	21Ch	—	29Ch	—	31Ch	—	39Ch	—
01Dh	—	09Dh	ADCON0/ AD1CON0 ⁽¹⁾	11Dh	APFCON	19Dh	RCSTA	21Dh	—	29Dh	—	31Dh	—	39Dh	—
01Eh	—	09Eh	ADCON1/ ADCOMCON ⁽¹⁾	11Eh	—	19Eh	TXSTA	21Eh	—	29Eh	—	31Eh	—	39Eh	—
01Fh	—	09Fh	ADCON2/ AD1CON2 ⁽¹⁾	11Fh	—	19Fh	BAUDCON	21Fh	—	29Fh	—	31Fh	—	39Fh	—
020h	General Purpose Register 96 Bytes	0A0h	General Purpose Register 80 Bytes	120h	General Purpose Register 80 Bytes	1A0h	Unimplemented Read as '0'	220h	Unimplemented Read as '0'	2A0h	Unimplemented Read as '0'	320h	Unimplemented Read as '0'	3A0h	Unimplemented Read as '0'
06Fh	—	0EFh	—	16Fh	—	1EFh	—	26Fh	—	2EFh	—	36Fh	—	36Fh	—
070h	—	0F0h	Accesses 70h – 7Fh	170h	Accesses 70h – 7Fh	1F0h	Accesses 70h – 7Fh	270h	Accesses 70h – 7Fh	2F0h	Accesses 70h – 7Fh	370h	Accesses 70h – 7Fh	3F0h	Accesses 70h – 7Fh
07Fh	—	0FFh	—	17Fh	—	1FFh	—	27Fh	—	2FFh	—	37Fh	—	3FFh	—

Legend: = Unimplemented data memory locations, read as '0'.

Note 1: These ADC registers are the same as the registers in Bank 14.

TABLE 3-4: PIC16LF1559 MEMORY MAP, BANKS 0-7

BANK 0		BANK 1		BANK 2		BANK 3		BANK 4		BANK 5		BANK 6		BANK 7					
000h	INDF0	080h	INDF0	100h	INDF0	180h	INDF0	200h	INDF0	280h	INDF0	300h	INDF0	380h	INDF0				
001h	INDF1	081h	INDF1	101h	INDF1	181h	INDF1	201h	INDF1	281h	INDF1	301h	INDF1	381h	INDF1				
002h	PCL	082h	PCL	102h	PCL	182h	PCL	202h	PCL	282h	PCL	302h	PCL	382h	PCL				
003h	STATUS	083h	STATUS	103h	STATUS	183h	STATUS	203h	STATUS	283h	STATUS	303h	STATUS	383h	STATUS				
004h	FSR0L	084h	FSR0L	104h	FSR0L	184h	FSR0L	204h	FSR0L	284h	FSR0L	304h	FSR0L	384h	FSR0L				
005h	FSR0H	085h	FSR0H	105h	FSR0H	185h	FSR0H	205h	FSR0H	285h	FSR0H	305h	FSR0H	385h	FSR0H				
006h	FSR1L	086h	FSR1L	106h	FSR1L	186h	FSR1L	206h	FSR1L	286h	FSR1L	306h	FSR1L	386h	FSR1L				
007h	FSR1H	087h	FSR1H	107h	FSR1H	187h	FSR1H	207h	FSR1H	287h	FSR1H	307h	FSR1H	387h	FSR1H				
008h	BSR	088h	BSR	108h	BSR	188h	BSR	208h	BSR	288h	BSR	308h	BSR	388h	BSR				
009h	WREG	089h	WREG	109h	WREG	189h	WREG	209h	WREG	289h	WREG	309h	WREG	389h	WREG				
00Ah	PCLATH	08Ah	PCLATH	10Ah	PCLATH	18Ah	PCLATH	20Ah	PCLATH	28Ah	PCLATH	30Ah	PCLATH	38Ah	PCLATH				
00Bh	INTCON	08Bh	INTCON	10Bh	INTCON	18Bh	INTCON	20Bh	INTCON	28Bh	INTCON	30Bh	INTCON	38Bh	INTCON				
00Ch	PORTA	08Ch	TRISA	10Ch	LATA	18Ch	ANSELA	20Ch	WPUA	28Ch	—	30Ch	—	38Ch	—				
00Dh	PORTB	08Dh	TRISB	10Dh	LATB	18Dh	ANSELB	20Dh	WPUB	28Dh	—	30Dh	—	38Dh	—				
00Eh	PORTC	08Eh	TRISC	10Eh	LATC	18Eh	ANSELC	20Eh	—	28Eh	—	30Eh	—	38Eh	—				
00Fh	—	08Fh	—	10Fh	—	18Fh	—	20Fh	—	28Fh	—	30Fh	—	38Fh	—				
010h	—	090h	—	110h	—	190h	—	210h	—	290h	—	310h	—	390h	—				
011h	PIR1	091h	PIE1	111h	—	191h	PMADRL	211h	SSPBUF	291h	—	311h	—	391h	IOCAP				
012h	PIR2	092h	PIE2	112h	—	192h	PMADRH	212h	SSPADD	292h	—	312h	—	392h	IOCAN				
013h	—	093h	—	113h	—	193h	PMDATL	213h	SSPMASK	293h	—	313h	—	393h	IOCAF				
014h	—	094h	—	114h	—	194h	PMDATH	214h	SSPSTAT	294h	—	314h	—	394h	IOCBP				
015h	TMR0	095h	OPTION	115h	—	195h	PMCON1	215h	SSPCON1	295h	—	315h	—	395h	IOCBN				
016h	TMR1L	096h	PCON	116h	BORCON	196h	PMCON2	216h	SSPCON2	296h	—	316h	—	396h	IOCBF				
017h	TMR1H	097h	WDTCON	117h	FVRCON	197h	—	217h	SSPCON3	297h	—	317h	—	397h	—				
018h	T1CON	098h	—	118h	—	198h	—	218h	—	298h	—	318h	—	398h	—				
019h	T1GCON	099h	OSCCON	119h	—	199h	RCREG	219h	—	299h	—	319h	—	399h	—				
01Ah	TMR2	09Ah	OSCSTAT	11Ah	—	19Ah	TXREG	21Ah	—	29Ah	—	31Ah	—	39Ah	—				
01Bh	PR2	09Bh	ADRESL/ AD1RES0L ⁽¹⁾	11Bh	—	19Bh	SPBRGL	21Bh	—	29Bh	—	31Bh	—	39Bh	—				
01Ch	T2CON	09Ch	ADRESH/ AD1RES0H ⁽¹⁾	11Ch	—	19Ch	SPBRGH	21Ch	—	29Ch	—	31Ch	—	39Ch	—				
01Dh	—	09Dh	ADCON0/ AD1CON0 ⁽¹⁾	11Dh	APFCON	19Dh	RCSTA	21Dh	—	29Dh	—	31Dh	—	39Dh	—				
01Eh	—	09Eh	ADCON1/ ADCOMCON ⁽¹⁾	11Eh	—	19Eh	TXSTA	21Eh	—	29Eh	—	31Eh	—	39Eh	—				
01Fh	—	09Fh	ADCON2/ AD1CON2 ⁽¹⁾	11Fh	—	19Fh	BAUDCON	21Fh	—	29Fh	—	31Fh	—	39Fh	—				
020h	General Purpose Register 96 Bytes	0A0h	General Purpose Register 80 Bytes	120h	General Purpose Register 80 Bytes	1A0h	General Purpose Register 80 Bytes	220h	General Purpose Register 80 Bytes	2A0h	General Purpose Register 80 Bytes	320h	General Purpose Register 16 Bytes	3A0h	Unimplemented Read as '0'				
																		330h	Unimplemented Read as '0'
																			36Fh
06Fh		0EFh		16Fh		1EFh		26Fh		2EFh		36Fh		3EFh					
070h		0F0h	Accesses 70h – 7Fh	170h	Accesses 70h – 7Fh	1F0h	Accesses 70h – 7Fh	270h	Accesses 70h – 7Fh	2F0h	Accesses 70h – 7Fh	370h	Accesses 70h – 7Fh	3F0h	Accesses 70h – 7Fh				
07Fh		0FFh		17Fh		1FFh		27Fh		2FFh		37Fh		3FFh					

Legend: = Unimplemented data memory locations, read as '0'.

Note 1: These ADC registers are the same as the registers in Bank 14.

TABLE 3-5: PIC16LF1554/1559 MEMORY MAP, BANKS 8-15

BANK 8		BANK 9		BANK 10		BANK 11		BANK 12		BANK 13		BANK 14		BANK 15	
400h	INDF0	480h	INDF0	500h	INDF0	580h	INDF0	600h	INDF0	680h	INDF0	700h	INDF0	780h	INDF0
401h	INDF1	481h	INDF1	501h	INDF1	581h	INDF1	601h	INDF1	681h	INDF1	701h	INDF1	781h	INDF1
402h	PCL	482h	PCL	502h	PCL	582h	PCL	602h	PCL	682h	PCL	702h	PCL	782h	PCL
403h	STATUS	483h	STATUS	503h	STATUS	583h	STATUS	603h	STATUS	683h	STATUS	703h	STATUS	783h	STATUS
404h	FSR0L	484h	FSR0L	504h	FSR0L	584h	FSR0L	604h	FSR0L	684h	FSR0L	704h	FSR0L	784h	FSR0L
405h	FSR0H	485h	FSR0H	505h	FSR0H	585h	FSR0H	605h	FSR0H	685h	FSR0H	705h	FSR0H	785h	FSR0H
406h	FSR1L	486h	FSR1L	506h	FSR1L	586h	FSR1L	606h	FSR1L	686h	FSR1L	706h	FSR1L	786h	FSR1L
407h	FSR1H	487h	FSR1H	507h	FSR1H	587h	FSR1H	607h	FSR1H	687h	FSR1H	707h	FSR1H	787h	FSR1H
408h	BSR	488h	BSR	508h	BSR	588h	BSR	608h	BSR	688h	BSR	708h	BSR	788h	BSR
409h	WREG	489h	WREG	509h	WREG	589h	WREG	609h	WREG	689h	WREG	709h	WREG	789h	WREG
40Ah	PCLATH	48Ah	PCLATH	50Ah	PCLATH	58Ah	PCLATH	60Ah	PCLATH	68Ah	PCLATH	70Ah	PCLATH	78Ah	PCLATH
40Bh	INTCON	48Bh	INTCON	50Bh	INTCON	58Bh	INTCON	60Bh	INTCON	68Bh	INTCON	70Bh	INTCON	78Bh	INTCON
40Ch	—	48Ch	—	50Ch	—	58Ch	—	60Ch	—	68Ch	—	70Ch	—	78Ch	—
40Dh	—	48Dh	—	50Dh	—	58Dh	—	60Dh	—	68Dh	—	70Dh	—	78Dh	—
40Eh	—	48Eh	—	50Eh	—	58Eh	—	60Eh	—	68Eh	—	70Eh	—	78Eh	—
40Fh	—	48Fh	—	50Fh	—	58Fh	—	60Fh	—	68Fh	—	70Fh	—	78Fh	—
410h	—	490h	—	510h	—	590h	—	610h	—	690h	—	710h	—	790h	—
411h	—	491h	—	511h	—	591h	—	611h	PWM1DCL	691h	—	711h	AD1CON0/ AAD1CON0 ⁽¹⁾	791h	AD2CON0/ AAD2CON0
412h	—	492h	—	512h	—	592h	—	612h	PWM1DCH	692h	—	712h	AADCON1/ ADCOMCON ⁽¹⁾	792h	—
413h	—	493h	—	513h	—	593h	—	613h	PWM1CON	693h	—	713h	AD1CON2/ AAD1CON2 ⁽¹⁾	793h	AD2CON2/ AAD2CON2
414h	—	494h	—	514h	—	594h	—	614h	PWM2DCL	694h	—	714h	AAD1CON3	794h	AAD2CON3
415h	—	495h	—	515h	—	595h	—	615h	PWM2DCH	695h	—	715h	AADSTAT	795h	—
416h	—	496h	—	516h	—	596h	—	616h	PWM2CON	696h	—	716h	AAD1PRE	796h	AAD2PRE
417h	—	497h	—	517h	—	597h	—	617h	—	697h	—	717h	AAD1ACQ	797h	AAD2ACQ
418h	—	498h	—	518h	—	598h	—	618h	—	698h	—	718h	AAD1GRD	798h	AAD2GRD
419h	—	499h	—	519h	—	599h	—	619h	—	699h	—	719h	AAD1CAP	799h	AAD2CAP
41Ah	—	49Ah	—	51Ah	—	59Ah	—	61Ah	—	69Ah	—	71Ah	AD1RES0L/ AAD1RES0L ⁽¹⁾	79Ah	AD2RES0L/ AAD2RES0L
41Bh	—	49Bh	—	51Bh	—	59Bh	—	61Bh	—	69Bh	—	71Bh	AD1RES0H/ AAD1RES0H ⁽¹⁾	79Bh	AD2RES0H/ AAD2RES0H
41Ch	—	49Ch	—	51Ch	—	59Ch	—	61Ch	—	69Ch	—	71Ch	AD1RES1L/ AAD1RES1L	79Ch	AD2RES1L/ AAD2RES1L
41Dh	—	49Dh	—	51Dh	—	59Dh	—	61Dh	—	69Dh	—	71Dh	AD1RES1H/ AAD1RES1H	79Dh	AD2RES1H/ AAD2RES1H
41Eh	—	49Eh	—	51Eh	—	59Eh	—	61Eh	—	69Eh	—	71Eh	AAD1CH	79Eh	AAD2CH
41Fh	—	49Fh	—	51Fh	—	59Fh	—	61Fh	—	69Fh	—	71Fh	—	79Fh	—
420h	Unimplemented Read as '0'	4A0h	Unimplemented Read as '0'	520h	Unimplemented Read as '0'	5A0h	Unimplemented Read as '0'	620h	Unimplemented Read as '0'	6A0h	Unimplemented Read as '0'	720h	Unimplemented Read as '0'	7A0h	Unimplemented Read as '0'
46Fh	—	4EFh	—	56Fh	—	5EFh	—	66Fh	—	6EFh	—	76Fh	—	7EFh	—
470h	Accesses 70h – 7Fh	4F0h	Accesses 70h – 7Fh	570h	Accesses 70h – 7Fh	5F0h	Accesses 70h – 7Fh	670h	Accesses 70h – 7Fh	6F0h	Accesses 70h – 7Fh	770h	Accesses 70h – 7Fh	7F0h	Accesses 70h – 7Fh
47Fh	—	4FFh	—	57Fh	—	5FFh	—	67Fh	—	6FFh	—	77Fh	—	7FFh	—

Note 1: These ADC registers are the same as the registers in Bank 1.

TABLE 3-6: PIC16LF1554/1559 MEMORY MAP, BANKS 16-23

BANK 16		BANK 17		BANK 18		BANK 19		BANK 20		BANK 21		BANK 22		BANK 23	
800h	INDF0	880h	INDF0	900h	INDF0	980h	INDF0	A00h	INDF0	A80h	INDF0	B00h	INDF0	B80h	INDF0
801h	INDF1	881h	INDF1	901h	INDF1	981h	INDF1	A01h	INDF1	A81h	INDF1	B01h	INDF1	B81h	INDF1
802h	PCL	882h	PCL	902h	PCL	982h	PCL	A02h	PCL	A82h	PCL	B02h	PCL	B82h	PCL
803h	STATUS	883h	STATUS	903h	STATUS	983h	STATUS	A03h	STATUS	A83h	STATUS	B03h	STATUS	B83h	STATUS
804h	FSR0L	884h	FSR0L	904h	FSR0L	984h	FSR0L	A04h	FSR0L	A84h	FSR0L	B04h	FSR0L	B84h	FSR0L
805h	FSR0H	885h	FSR0H	905h	FSR0H	985h	FSR0H	A05h	FSR0H	A85h	FSR0H	B05h	FSR0H	B85h	FSR0H
806h	FSR1L	886h	FSR1L	906h	FSR1L	986h	FSR1L	A06h	FSR1L	A86h	FSR1L	B06h	FSR1L	B86h	FSR1L
807h	FSR1H	887h	FSR1H	907h	FSR1H	987h	FSR1H	A07h	FSR1H	A87h	FSR1H	B07h	FSR1H	B87h	FSR1H
808h	BSR	888h	BSR	908h	BSR	988h	BSR	A08h	BSR	A88h	BSR	B08h	BSR	B88h	BSR
809h	WREG	889h	WREG	909h	WREG	989h	WREG	A09h	WREG	A89h	WREG	B09h	WREG	B89h	WREG
80Ah	PCLATH	88Ah	PCLATH	90Ah	PCLATH	98Ah	PCLATH	A0Ah	PCLATH	A8Ah	PCLATH	B0Ah	PCLATH	B8Ah	PCLATH
80Bh	INTCON	88Bh	INTCON	90Bh	INTCON	98Bh	INTCON	A0Bh	INTCON	A8Bh	INTCON	B0Bh	INTCON	B8Bh	INTCON
80Ch	—	88Ch	—	90Ch	—	98Ch	—	A0Ch	—	A8Ch	—	B0Ch	—	B8Ch	—
80Dh	—	88Dh	—	90Dh	—	98Dh	—	A0Dh	—	A8Dh	—	B0Dh	—	B8Dh	—
80Eh	—	88Eh	—	90Eh	—	98Eh	—	A0Eh	—	A8Eh	—	B0Eh	—	B8Eh	—
80Fh	—	88Fh	—	90Fh	—	98Fh	—	A0Fh	—	A8Fh	—	B0Fh	—	B8Fh	—
810h	—	890h	—	910h	—	990h	—	A10h	—	A90h	—	B10h	—	B90h	—
811h	—	891h	—	911h	—	991h	—	A11h	—	A91h	—	B11h	—	B91h	—
812h	—	892h	—	912h	—	992h	—	A12h	—	A92h	—	B12h	—	B92h	—
813h	—	893h	—	913h	—	993h	—	A13h	—	A93h	—	B13h	—	B93h	—
814h	—	894h	—	914h	—	994h	—	A14h	—	A94h	—	B14h	—	B94h	—
815h	—	895h	—	915h	—	995h	—	A15h	—	A95h	—	B15h	—	B95h	—
816h	—	896h	—	916h	—	996h	—	A16h	—	A96h	—	B16h	—	B96h	—
817h	—	897h	—	917h	—	997h	—	A17h	—	A97h	—	B17h	—	B97h	—
818h	—	898h	—	918h	—	998h	—	A18h	—	A98h	—	B18h	—	B98h	—
819h	—	899h	—	919h	—	999h	—	A19h	—	A99h	—	B19h	—	B99h	—
81Ah	—	89Ah	—	91Ah	—	99Ah	—	A1Ah	—	A9Ah	—	B1Ah	—	B9Ah	—
81Bh	—	89Bh	—	91Bh	—	99Bh	—	A1Bh	—	A9Bh	—	B1Bh	—	B9Bh	—
81Ch	—	89Ch	—	91Ch	—	99Ch	—	A1Ch	—	A9Ch	—	B1Ch	—	B9Ch	—
81Dh	—	89Dh	—	91Dh	—	99Dh	—	A1Dh	—	A9Dh	—	B1Dh	—	B9Dh	—
81Eh	—	89Eh	—	91Eh	—	99Eh	—	A1Eh	—	A9Eh	—	B1Eh	—	B9Eh	—
81Fh	—	89Fh	—	91Fh	—	99Fh	—	A1Fh	—	A9Fh	—	B1Fh	—	B9Fh	—
820h	Unimplemented Read as '0'	8A0h	Unimplemented Read as '0'	920h	Unimplemented Read as '0'	9A0h	Unimplemented Read as '0'	A20h	Unimplemented Read as '0'	AA0h	Unimplemented Read as '0'	B20h	Unimplemented Read as '0'	BA0h	Unimplemented Read as '0'
86Fh	—	8EFh	—	96Fh	—	9EFh	—	A6Fh	—	AEFh	—	B6Fh	—	BEFh	—
870h	Accesses 70h – 7Fh	8F0h	Accesses 70h – 7Fh	970h	Accesses 70h – 7Fh	9F0h	Accesses 70h – 7Fh	A70h	Accesses 70h – 7Fh	AF0h	Accesses 70h – 7Fh	B70h	Accesses 70h – 7Fh	BF0h	Accesses 70h – 7Fh
87Fh	—	8FFh	—	97Fh	—	9FFh	—	A7Fh	—	AFFh	—	B7Fh	—	BFFh	—

TABLE 3-7: PIC16LF1554/1559 MEMORY MAP, BANKS 24-31

BANK 24		BANK 25		BANK 26		BANK 27		BANK 28		BANK 29		BANK 30		BANK 31	
C00h	INDF0	C80h	INDF0	D00h	INDF0	D80h	INDF0	E00h	INDF0	E80h	INDF0	F00h	INDF0	F80h	INDF0
C01h	INDF1	C81h	INDF1	D01h	INDF1	D81h	INDF1	E01h	INDF1	E81h	INDF1	F01h	INDF1	F81h	INDF1
C02h	PCL	C82h	PCL	D02h	PCL	D82h	PCL	E02h	PCL	E82h	PCL	F02h	PCL	F82h	PCL
C03h	STATUS	C83h	STATUS	D03h	STATUS	D83h	STATUS	E03h	STATUS	E83h	STATUS	F03h	STATUS	F83h	STATUS
C04h	FSR0L	C84h	FSR0L	D04h	FSR0L	D84h	FSR0L	E04h	FSR0L	E84h	FSR0L	F04h	FSR0L	F84h	FSR0L
C05h	FSR0H	C85h	FSR0H	D05h	FSR0H	D85h	FSR0H	E05h	FSR0H	E85h	FSR0H	F05h	FSR0H	F85h	FSR0H
C06h	FSR1L	C86h	FSR1L	D06h	FSR1L	D86h	FSR1L	E06h	FSR1L	E86h	FSR1L	F06h	FSR1L	F86h	FSR1L
C07h	FSR1H	C87h	FSR1H	D07h	FSR1H	D87h	FSR1H	E07h	FSR1H	E87h	FSR1H	F07h	FSR1H	F87h	FSR1H
C08h	BSR	C88h	BSR	D08h	BSR	D88h	BSR	E08h	BSR	E88h	BSR	F08h	BSR	F88h	BSR
C09h	WREG	C89h	WREG	D09h	WREG	D89h	WREG	E09h	WREG	E89h	WREG	F09h	WREG	F89h	WREG
C0Ah	PCLATH	C8Ah	PCLATH	D0Ah	PCLATH	D8Ah	PCLATH	E0Ah	PCLATH	E8Ah	PCLATH	F0Ah	PCLATH	F8Ah	PCLATH
C0Bh	INTCON	C8Bh	INTCON	D0Bh	INTCON	D8Bh	INTCON	E0Bh	INTCON	E8Bh	INTCON	F0Bh	INTCON	F8Bh	INTCON
C0Ch	—	C8Ch	—	D0Ch	—	D8Ch	—	E0Ch	—	E8Ch	—	F0Ch	—	F8Ch	See Table 3-9 for register mapping details
C0Dh	—	C8Dh	—	D0Dh	—	D8Dh	—	E0Dh	—	E8Dh	—	F0Dh	—	F8Dh	
C0Eh	—	C8Eh	—	D0Eh	—	D8Eh	—	E0Eh	—	E8Eh	—	F0Eh	—	F8Eh	
C0Fh	—	C8Fh	—	D0Fh	—	D8Fh	—	E0Fh	—	E8Fh	—	F0Fh	—	F8Fh	
C10h	—	C90h	—	D10h	—	D90h	—	E10h	—	E90h	—	F10h	—	F90h	
C11h	—	C91h	—	D11h	—	D91h	—	E11h	—	E91h	—	F11h	—	F91h	
C12h	—	C92h	—	D12h	—	D92h	—	E12h	—	E92h	—	F12h	—	F92h	
C13h	—	C93h	—	D13h	—	D93h	—	E13h	—	E93h	—	F13h	—	F93h	
C14h	—	C94h	—	D14h	—	D94h	—	E14h	—	E94h	—	F14h	—	F94h	
C15h	—	C95h	—	D15h	—	D95h	—	E15h	—	E95h	—	F15h	—	F95h	
C16h	—	C96h	—	D16h	—	D96h	—	E16h	—	E96h	—	F16h	—	F96h	
C17h	—	C97h	—	D17h	—	D97h	—	E17h	—	E97h	—	F17h	—	F97h	
C18h	—	C98h	—	D18h	—	D98h	—	E18h	—	E98h	—	F18h	—	F98h	
C19h	—	C99h	—	D19h	—	D99h	—	E19h	—	E99h	—	F19h	—	F99h	
C1Ah	—	C9Ah	—	D1Ah	—	D9Ah	—	E1Ah	—	E9Ah	—	F1Ah	—	F9Ah	
C1Bh	—	C9Bh	—	D1Bh	—	D9Bh	—	E1Bh	—	E9Bh	—	F1Bh	—	F9Bh	
C1Ch	—	C9Ch	—	D1Ch	—	D9Ch	—	E1Ch	—	E9Ch	—	F1Ch	—	F9Ch	
C1Dh	—	C9Dh	—	D1Dh	—	D9Dh	—	E1Dh	—	E9Dh	—	F1Dh	—	F9Dh	
C1Eh	—	C9Eh	—	D1Eh	—	D9Eh	—	E1Eh	—	E9Eh	—	F1Eh	—	F9Eh	
C1Fh	—	C9Fh	—	D1Fh	—	D9Fh	—	E1Fh	—	E9Fh	—	F1Fh	—	F9Fh	
C20h	Unimplemented Read as '0'	CA0h	Unimplemented Read as '0'	D20h	Unimplemented Read as '0'	DA0h	Unimplemented Read as '0'	E20h	Unimplemented Read as '0'	EA0h	Unimplemented Read as '0'	F20h	Unimplemented Read as '0'	FA0h	
C6Fh	—	CEFh	—	D6Fh	—	DEFh	—	E6Fh	—	EEFh	—	F6Fh	—	FEFh	
C70h	Accesses 70h – 7Fh	CF0h	Accesses 70h – 7Fh	D70h	Accesses 70h – 7Fh	DF0h	Accesses 70h – 7Fh	E70h	Accesses 70h – 7Fh	EF0h	Accesses 70h – 7Fh	F70h	Accesses 70h – 7Fh	F0h	Accesses 70h – 7Fh
FFFh	—	FFFh	—	D7Fh	—	FFFh	—	E7Fh	—	FFFh	—	F7Fh	—	FFFh	

Legend: ■ = Unimplemented data memory locations, read as '0'.

3.2.6 CORE FUNCTION REGISTERS SUMMARY

The Core Function registers listed in [Table 3-8](#) can be addressed from any Bank.

TABLE 3-8: CORE FUNCTION REGISTERS SUMMARY

Addr.	Name	Bit 7	Bit 6	Bit 5	Bit 4	Bit 3	Bit 2	Bit 1	Bit 0	Value on POR, BOR	Value on all other Resets	
Bank 0-31												
x00h or x80h	INDF0	Addressing this location uses contents of FSR0H/FSR0L to address data memory (not a physical register)								xxxx xxxx	uuuu uuuu	
x01h or x81h	INDF1	Addressing this location uses contents of FSR1H/FSR1L to address data memory (not a physical register)								xxxx xxxx	uuuu uuuu	
x02h or x82h	PCL	Program Counter (PC) Least Significant Byte								0000 0000	0000 0000	
x03h or x83h	STATUS	—	—	—	\overline{TO}	\overline{PD}	Z	DC	C	---1 1000	---q quuu	
x04h or x84h	FSR0L	Indirect Data Memory Address 0 Low Pointer								0000 0000	uuuu uuuu	
x05h or x85h	FSR0H	Indirect Data Memory Address 0 High Pointer								0000 0000	0000 0000	
x06h or x86h	FSR1L	Indirect Data Memory Address 1 Low Pointer								0000 0000	uuuu uuuu	
x07h or x87h	FSR1H	Indirect Data Memory Address 1 High Pointer								0000 0000	0000 0000	
x08h or x88h	BSR	—	—	—	BSR<4:0>				---	0 0000	---	0 0000
x09h or x89h	WREG	Working Register								0000 0000	uuuu uuuu	
x0Ah or x8Ah	PCLATH	—	Write Buffer for the upper 7 bits of the Program Counter								-000 0000	-000 0000
x0Bh or x8Bh	INTCON	GIE	PEIE	TMR0IE	INTE	IOCIE	TMR0IF	INTF	IOCIF	0000 0000	0000 0000	

Legend: x = unknown, u = unchanged, q = value depends on condition, - = unimplemented, read as '0', r = reserved.
Shaded locations are unimplemented, read as '0'.

PIC16LF1554/1559

TABLE 3-9: SPECIAL FUNCTION REGISTER SUMMARY

Address	Name	Bit 7	Bit 6	Bit 5	Bit 4	Bit 3	Bit 2	Bit 1	Bit 0	Value on: POR, BOR	Value on all other Resets	
Bank 0												
000h	INDF0 ⁽¹⁾	Addressing this location uses contents of FSR0H/FSR0L to address data memory (not a physical register)								xxxx xxxx	uuuu uuuu	
001h	INDF1 ⁽¹⁾	Addressing this location uses contents of FSR1H/FSR1L to address data memory (not a physical register)								xxxx xxxx	uuuu uuuu	
002h	PCL ⁽¹⁾	Program Counter (PC) Least Significant Byte								0000 0000	0000 0000	
003h	STATUS ⁽¹⁾	—	—	—	\overline{TO}	\overline{PD}	Z	DC	C	---1 1000	---q quuu	
004h	FSR0L ⁽¹⁾	Indirect Data Memory Address 0 Low Pointer								0000 0000	uuuu uuuu	
005h	FSR0H ⁽¹⁾	Indirect Data Memory Address 0 High Pointer								0000 0000	0000 0000	
006h	FSR1L ⁽¹⁾	Indirect Data Memory Address 1 Low Pointer								0000 0000	uuuu uuuu	
007h	FSR1H ⁽¹⁾	Indirect Data Memory Address 1 High Pointer								0000 0000	0000 0000	
008h	BSR ⁽¹⁾	—	—	—	BSR<4:0>				---	0 0000	---	0 0000
009h	WREG ⁽¹⁾	Working Register								0000 0000	uuuu uuuu	
00Ah	PCLATH ⁽¹⁾	—	Write Buffer for the upper 7 bits of the Program Counter								-000 0000	-000 0000
00Bh	INTCON ⁽¹⁾	GIE	PEIE	TMR0IE	INTE	IOCFIE	TMR0IF	INTF	IOCFIF	0000 0000	0000 0000	
00Ch	PORTA	—	—	RA5	RA4	RA3	RA2	RA1	RA0	--xx xxxx	--xx xxxx	
00Dh	PORTB ⁽²⁾	Unimplemented								—	—	
	PORTB ⁽³⁾	RB7	RB6	RB5	RB4	—	—	—	—	xxxx ----	xxxx ----	
00Eh	PORTC ⁽²⁾	—	—	RC5	RC4	RC3	RC2	RC1	RC0	--xx xxxx	--xx xxxx	
	PORTC ⁽³⁾	RC7	RC6	RC5	RC4	RC3	RC2	RC1	RC0	xxxx xxxx	xxxx xxxx	
011h	PIR1	TMR1GIF	AD1IF	RCIF	TXIF	SSP1IF	—	TMR2IF	TMR1IF	0000 0-00	0000 0-00	
012h	PIR2	—	AD2IF	—	—	BCLIF	—	—	—	-0-- 0---	-0-- 0---	
015h	TMR0	Timer0 Module Register								xxxx xxxx	uuuu uuuu	
016h	TMR1L	Holding Register for the Least Significant Byte of the 16-bit TMR1 Count								xxxx xxxx	uuuu uuuu	
017h	TMR1H	Holding Register for the Most Significant Byte of the 16-bit TMR1 Count								xxxx xxxx	uuuu uuuu	
018h	T1CON	TMR1CS<1:0>		T1CKPS<1:0>		—	$\overline{T1SYNC}$	—	TMR1ON	0000 -0-0	uuuu -u-u	
019h	T1GCON	TMR1GE	T1GPOL	T1GTM	T1GSPM	$\overline{T1GGO/DONE}$	T1GVAL	—	T1GSS	0000 0x-0	uuuu ux-u	
01Ah	TMR2	Timer 2 Module Register								0000 0000	0000 0000	
01Bh	PR2	Timer 2 Period Register								1111 1111	1111 1111	
01Ch	T2CON	—	T2OUTPS<3:0>				TMR2ON	T2CKPS<1:0>		-000 0000	-000 0000	
01Dh	—	Unimplemented								—	—	
01Eh	—	Unimplemented								—	—	
01Fh	—	Unimplemented								—	—	

Legend: x = unknown, u = unchanged, q = depends on condition, - = unimplemented, read as '0', r = reserved. Shaded locations unimplemented, read as '0'.

- Note**
- 1: These registers can be accessed from any bank.
 - 2: PIC16LF1554.
 - 3: PIC16LF1559.
 - 4: These registers/bits are available at two address locations, in Bank 1 and Bank 14.

PIC16LF1554/1559

TABLE 3-9: SPECIAL FUNCTION REGISTER SUMMARY (CONTINUED)

Address	Name	Bit 7	Bit 6	Bit 5	Bit 4	Bit 3	Bit 2	Bit 1	Bit 0	Value on: POR, BOR	Value on all other Resets	
Bank 1												
080h	INDF0 ⁽¹⁾	Addressing this location uses contents of FSR0H/FSR0L to address data memory (not a physical register)								xxxx xxxx	uuuu uuuu	
081h	INDF1 ⁽¹⁾	Addressing this location uses contents of FSR1H/FSR1L to address data memory (not a physical register)								xxxx xxxx	uuuu uuuu	
082h	PCL ⁽¹⁾	Program Counter (PC) Least Significant Byte								0000 0000	0000 0000	
083h	STATUS ⁽¹⁾	—	—	—	\overline{TO}	\overline{PD}	Z	DC	C	---1 1000	---q quuu	
084h	FSR0L ⁽¹⁾	Indirect Data Memory Address 0 Low Pointer								0000 0000	uuuu uuuu	
085h	FSR0H ⁽¹⁾	Indirect Data Memory Address 0 High Pointer								0000 0000	0000 0000	
086h	FSR1L ⁽¹⁾	Indirect Data Memory Address 1 Low Pointer								0000 0000	uuuu uuuu	
087h	FSR1H ⁽¹⁾	Indirect Data Memory Address 1 High Pointer								0000 0000	0000 0000	
088h	BSR ⁽¹⁾	—	—	—	BSR<4:0>					---0 0000	---0 0000	
089h	WREG ⁽¹⁾	Working Register								0000 0000	uuuu uuuu	
08Ah	PCLATH ⁽¹⁾	—	Write Buffer for the upper 7 bits of the Program Counter								-000 0000	-000 0000
08Bh	INTCON ⁽¹⁾	GIE	PEIE	TMR0IE	INTE	IOCFIE	TMR0IF	INTF	IOCF	0000 0000	0000 0000	
08Ch	TRISA	—	—	TRISA5	TRISA4	—	TRISA2	TRISA1	TRISA0	--11 1111	--11 1111	
08Dh	TRISB ⁽²⁾	Unimplemented								—	—	
	TRISB ⁽³⁾	TRISB7	TRISB6	TRISB5	TRISB4	—	—	—	—	1111 ----	1111 ----	
08Eh	TRISC ⁽²⁾	—	—	TRISC5	TRISC4	TRISC3	TRISC2	TRISC1	TRISC0	--11 1111	--11 1111	
	TRISC ⁽³⁾	TRISC7	TRISC6	TRISC5	TRISC4	TRISC3	TRISC2	TRISC1	TRISC0	1111 1111	1111 1111	
091h	PIE1	TMR1GIE	AD1IE	RCIE	TXIE	SSP1IE	—	TMR2IE	TMR1IE	0000 0-00	0000 0-00	
092h	PIE2	—	AD2IE	—	—	BCLIE	—	—	—	-0-- 0---	-0-- 0---	
095h	OPTION_REG	\overline{WPUEN}	INTEDG	TMR0CS	TMR0SE	PSA	PS<2:0>			1111 1111	1111 1111	
096h	PCON	STKOVF	STKUNF	—	\overline{RWDT}	\overline{RMCLR}	\overline{RI}	\overline{POR}	\overline{BOR}	00-1 11qq	00-q qquu	
097h	WDTCON	—	—	WDTPS<4:0>					SWDTEN	--01 0110	--01 0110	
098h	—	Unimplemented								—	—	
099h	OSCCON	SPLLEN	IRCF<3:0>				—	SCS<1:0>			0011 1-00	0011 1-00
09Ah	OSCSTAT	—	PLLSR	—	HFIOFR	—	—	LFIOFR	HFIOFS	-0-0 --00	-q-q -q0q	
09Bh	ADRESL/ AD1RES0L ⁽⁴⁾	ADC1 Result Register 0 Low								xxxx xxxx	uuuu uuuu	
09Ch	ADRESH/ AD1RES0H ⁽⁴⁾	ADC1 Result Register 0 High								xxxx xxxx	uuuu uuuu	
09Dh	ADCON0/ AD1CON0 ⁽⁴⁾	—	CHS14	CHS13	CHS12	CHS11	CHS10	GO/ \overline{DONE} 1	AD1ON	-000 0000	-000 0000	
09Eh	ADCON1/ ADCOMCON ⁽⁴⁾	ADFM	ADCS<2:0>			—	$\overline{GO}/$ DONE_ALL	ADPREF<1:0>			0000 -000	0000 -000
09Fh	ADCON2/ AD1CON2 ⁽⁴⁾	—	TRIGSEL1<2:0>			—	—	—	—	-000 ----	-000 ----	

Legend: x = unknown, u = unchanged, q = depends on condition, - = unimplemented, read as '0', r = reserved. Shaded locations unimplemented, read as '0'.

- Note**
- 1: These registers can be accessed from any bank.
 - 2: PIC16LF1554.
 - 3: PIC16LF1559.
 - 4: These registers/bits are available at two address locations, in Bank 1 and Bank 14.

PIC16LF1554/1559

TABLE 3-9: SPECIAL FUNCTION REGISTER SUMMARY (CONTINUED)

Address	Name	Bit 7	Bit 6	Bit 5	Bit 4	Bit 3	Bit 2	Bit 1	Bit 0	Value on: POR, BOR	Value on all other Resets	
Bank 2												
100h	INDF0 ⁽¹⁾	Addressing this location uses contents of FSR0H/FSR0L to address data memory (not a physical register)								xxxx xxxx	uuuu uuuu	
101h	INDF1 ⁽¹⁾	Addressing this location uses contents of FSR1H/FSR1L to address data memory (not a physical register)								xxxx xxxx	uuuu uuuu	
102h	PCL ⁽¹⁾	Program Counter (PC) Least Significant Byte								0000 0000	0000 0000	
103h	STATUS ⁽¹⁾	—	—	—	\overline{TO}	\overline{PD}	Z	DC	C	---1 1000	---q quuu	
104h	FSR0L ⁽¹⁾	Indirect Data Memory Address 0 Low Pointer								0000 0000	uuuu uuuu	
105h	FSR0H ⁽¹⁾	Indirect Data Memory Address 0 High Pointer								0000 0000	0000 0000	
106h	FSR1L ⁽¹⁾	Indirect Data Memory Address 1 Low Pointer								0000 0000	uuuu uuuu	
107h	FSR1H ⁽¹⁾	Indirect Data Memory Address 1 High Pointer								0000 0000	0000 0000	
108h	BSR ⁽¹⁾	—	—	—	BSR<4:0>			—	—	---0 0000	---0 0000	
109h	WREG ⁽¹⁾	Working Register								0000 0000	uuuu uuuu	
10Ah	PCLATH ⁽¹⁾	—	Write Buffer for the upper 7 bits of the Program Counter								-000 0000	-000 0000
10Bh	INTCON ⁽¹⁾	GIE	PEIE	TMR0IE	INTE	IOCFIE	TMR0IF	INTF	IOCFIF	0000 0000	0000 0000	
10Ch	LATA	—	—	LATA5	LATA4	—	LATA2	LATA1	LATA0	--xx xxxx	--uu uuuu	
10Dh	LATB ⁽²⁾	Unimplemented								—	—	
	LATB ⁽³⁾	LATB7	LATB6	LATB5	LATB4	—	—	—	—	xxxx ----	uuuu ----	
10Eh	LATC ⁽²⁾	—	—	LATC5	LATC4	LATC3	LATC2	LATC1	LATC0	--xx xxxx	--uu uuuu	
	LATC ⁽³⁾	LATC7	LATC6	LATC5	LATC4	LATC3	LATC2	LATC1	LATC0	xxxx xxxx	uuuu uuuu	
10Fh	—	Unimplemented								—	—	
110h	—	Unimplemented								—	—	
111h	—	Unimplemented								—	—	
112h	—	Unimplemented								—	—	
113h	—	Unimplemented								—	—	
114h	—	Unimplemented								—	—	
115h	—	Unimplemented								—	—	
116h	BORCON	SBOREN	BORF5	—	—	—	—	—	BORRDY	10-- ---q	uu-- ---u	
117h	FVRCON	FVREN	FVRRDY	TSEN	TSRNG	—	—	ADFVR<1:0>		0q00 --00	0q00 --00	
118h	—	Unimplemented								—	—	
119h	—	Unimplemented								—	—	
11Ah	—	Unimplemented								—	—	
11Bh	—	Unimplemented								—	—	
11Ch	—	Unimplemented								—	—	
11Dh	APFCON	RXDTSEL	SDOSEL	SSSEL	SDSEL	—	TXCKSEL	GRDBSEL	GRDASEL	0000 -000	0000 -000	
11Eh	—	Unimplemented								—	—	
11Fh	—	Unimplemented								—	—	

Legend: x = unknown, u = unchanged, q = depends on condition, - = unimplemented, read as '0', r = reserved. Shaded locations unimplemented, read as '0'.

Note 1: These registers can be accessed from any bank.

Note 2: PIC16LF1554.

Note 3: PIC16LF1559.

Note 4: These registers/bits are available at two address locations, in Bank 1 and Bank 14.

PIC16LF1554/1559

TABLE 3-9: SPECIAL FUNCTION REGISTER SUMMARY (CONTINUED)

Address	Name	Bit 7	Bit 6	Bit 5	Bit 4	Bit 3	Bit 2	Bit 1	Bit 0	Value on: POR, BOR	Value on all other Resets	
Bank 3												
180h	INDF0 ⁽¹⁾	Addressing this location uses contents of FSR0H/FSR0L to address data memory (not a physical register)								xxxx xxxx	uuuu uuuu	
181h	INDF1 ⁽¹⁾	Addressing this location uses contents of FSR1H/FSR1L to address data memory (not a physical register)								xxxx xxxx	uuuu uuuu	
182h	PCL ⁽¹⁾	Program Counter (PC) Least Significant Byte								0000 0000	0000 0000	
183h	STATUS ⁽¹⁾	—	—	—	\overline{TO}	\overline{PD}	Z	DC	C	---1 1000	---q quuu	
184h	FSR0L ⁽¹⁾	Indirect Data Memory Address 0 Low Pointer								0000 0000	uuuu uuuu	
185h	FSR0H ⁽¹⁾	Indirect Data Memory Address 0 High Pointer								0000 0000	0000 0000	
186h	FSR1L ⁽¹⁾	Indirect Data Memory Address 1 Low Pointer								0000 0000	uuuu uuuu	
187h	FSR1H ⁽¹⁾	Indirect Data Memory Address 1 High Pointer								0000 0000	0000 0000	
188h	BSR ⁽¹⁾	—	—	—	BSR<4:0>					---0 0000	---0 0000	
189h	WREG ⁽¹⁾	Working Register								0000 0000	uuuu uuuu	
18Ah	PCLATH ⁽¹⁾	—	Write Buffer for the upper 7 bits of the Program Counter								-000 0000	-000 0000
18Bh	INTCON ⁽¹⁾	GIE	PEIE	TMR0IE	INTE	IOCIE	TMR0IF	INTF	IOCIF	0000 0000	0000 0000	
18Ch	ANSELA	—	—	ANSA5	ANSA4	—	ANSA2	ANSA1	ANSA0	1111 -111	1111 -111	
18Dh	ANSELB ⁽²⁾	Unimplemented								—	—	
	ANSELB ⁽³⁾	ANSB7	ANSB6	ANSB5	ANSB4	—	—	—	—	1111 ----	1111 ----	
18Eh	ANSELC ⁽²⁾	—	—	ANSC5	ANSC4	ANSC3	ANSC2	ANSC1	ANSC0	--11 1111	--11 1111	
	ANSELC ⁽³⁾	ANSC7	ANSC6	ANSC5	ANSC4	ANSC3	ANSC2	ANSC1	ANSC0	1111 1111	1111 1111	
18Fh	—	Unimplemented								—	—	
190h	—	Unimplemented								—	—	
191h	PMADRL	Program Memory Address Register Low Byte								0000 0000	0000 0000	
192h	PMADRH	—	Program Memory Address Register High Byte								1000 0000	1000 0000
193h	PMDATL	Program Memory Read Data Register Low Byte								xxxx xxxx	uuuu uuuu	
194h	PMDATH	—	—	Program Memory Read Data Register High Byte						--xx xxxx	--uu uuuu	
195h	PMCON1	—	CFGS	LWLO	FREE	WRERR	WREN	WR	RD	-000 x000	-000 q000	
196h	PMCON2	Program Memory Control Register 2								0000 0000	0000 0000	
197h	—	Unimplemented								—	—	
198h	—	Unimplemented								—	—	
199h	RCREG	USART Receive Data Register								0000 0000	0000 0000	
19Ah	TXREG	USART Transmit Data Register								0000 0000	0000 0000	
19Bh	SPBRGL	SPBRG Low								0000 0000	0000 0000	
19Ch	SPBRGH	SPBRG High								0000 0000	0000 0000	
19Dh	RCSTA	SPEN	RX9	SREN	CREN	ADDEN	FERR	OERR	RX9D	0000 000x	0000 000x	
19Eh	TXSTA	CSRC	TX9	TXEN	SYNC	SENDB	BRGH	TRMT	TX9D	0000 0010	0000 0010	
19Fh	BAUDCON	ABDOVF	RCIDL	—	SCKP	BRG16	—	WUE	ABDEN	01-0 0-00	01-0 0-00	

Legend: x = unknown, u = unchanged, q = depends on condition, - = unimplemented, read as '0', r = reserved. Shaded locations unimplemented, read as '0'.

Note 1: These registers can be accessed from any bank.

2: PIC16LF1554.

3: PIC16LF1559.

4: These registers/bits are available at two address locations, in Bank 1 and Bank 14.

PIC16LF1554/1559

TABLE 3-9: SPECIAL FUNCTION REGISTER SUMMARY (CONTINUED)

Address	Name	Bit 7	Bit 6	Bit 5	Bit 4	Bit 3	Bit 2	Bit 1	Bit 0	Value on: POR, BOR	Value on all other Resets	
Bank 4												
200h	INDF0 ⁽¹⁾	Addressing this location uses contents of FSR0H/FSR0L to address data memory (not a physical register)								xxxx xxxx	uuuu uuuu	
201h	INDF1 ⁽¹⁾	Addressing this location uses contents of FSR1H/FSR1L to address data memory (not a physical register)								xxxx xxxx	uuuu uuuu	
202h	PCL ⁽¹⁾	Program Counter (PC) Least Significant Byte								0000 0000	0000 0000	
203h	STATUS ⁽¹⁾	—	—	—	\overline{TO}	\overline{PD}	Z	DC	C	---1 1000	---q quuu	
204h	FSR0L ⁽¹⁾	Indirect Data Memory Address 0 Low Pointer								0000 0000	uuuu uuuu	
205h	FSR0H ⁽¹⁾	Indirect Data Memory Address 0 High Pointer								0000 0000	0000 0000	
206h	FSR1L ⁽¹⁾	Indirect Data Memory Address 1 Low Pointer								0000 0000	uuuu uuuu	
207h	FSR1H ⁽¹⁾	Indirect Data Memory Address 1 High Pointer								0000 0000	0000 0000	
208h	BSR ⁽¹⁾	—	—	—	BSR<4:0>				---	0 0000	---	0 0000
209h	WREG ⁽¹⁾	Working Register								0000 0000	uuuu uuuu	
20Ah	PCLATH ⁽¹⁾	—	Write Buffer for the upper 7 bits of the Program Counter								-000 0000	-000 0000
20Bh	INTCON ⁽¹⁾	GIE	PEIE	TMR0IE	INTE	IOCIE	TMR0IF	INTF	IOCIF	0000 0000	0000 0000	
20Ch	WPUA	—	—	WPUA5	WPUA4	WPUA3	WPUA2	WPUA1	WPUA0	--11 1111	--11 1111	
20Dh	WPUB ⁽²⁾	Unimplemented								—	—	
	WPUB ⁽³⁾	WPUB7	WPUB6	WPUB5	WPUB4	—	—	—	—	1111 ----	1111 ----	
20Eh	—	Unimplemented								—	—	
20Fh	—	Unimplemented								—	—	
210h	—	Unimplemented								—	—	
211h	SSPBUF	Synchronous Serial Port Receive Buffer/Transmit Register								xxxx xxxx	uuuu uuuu	
212h	SSPAD	Synchronous Serial Port (I ² C™ mode) Address Register								0000 0000	0000 0000	
213h	SSPMSK	Synchronous Serial Port (I ² C mode) Address Mask Register								1111 1111	1111 1111	
214h	SSPSTAT	SMP	CKE	D/ \overline{A}	P	S	R/ \overline{W}	UA	BF	0000 0000	0000 0000	
215h	SSPCON1	WCOL	SSPOV	SSPEN	CKP	SSPM3	SSPM2	SSPM1	SSPM0	0000 0000	0000 0000	
216h	SSPCON2	GCEN	ACKSTAT	ACKDT	ACKEN	RCEN	PEN	RSEN	SEN	0000 0000	0000 0000	
217h	SSPCON3	ACKTIM	PCIE	SCIE	BOEN	SDAHT	SBCDE	AHEN	DHEN	0000 0000	0000 0000	
218h	—	Unimplemented								—	—	
219h	—	Unimplemented								—	—	
21Ah	—	Unimplemented								—	—	
21Bh	—	Unimplemented								—	—	
21Ch	—	Unimplemented								—	—	
21Dh	—	Unimplemented								—	—	
21Eh	—	Unimplemented								—	—	
21Fh	—	Unimplemented								—	—	

Legend: x = unknown, u = unchanged, q = depends on condition, - = unimplemented, read as '0', r = reserved. Shaded locations unimplemented, read as '0'.

Note 1: These registers can be accessed from any bank.

2: PIC16LF1554.

3: PIC16LF1559.

4: These registers/bits are available at two address locations, in Bank 1 and Bank 14.

PIC16LF1554/1559

TABLE 3-9: SPECIAL FUNCTION REGISTER SUMMARY (CONTINUED)

Address	Name	Bit 7	Bit 6	Bit 5	Bit 4	Bit 3	Bit 2	Bit 1	Bit 0	Value on: POR, BOR	Value on all other Resets	
Bank 5												
280h	INDF0 ⁽¹⁾	Addressing this location uses contents of FSR0H/FSR0L to address data memory (not a physical register)								xxxx xxxx	uuuu uuuu	
281h	INDF1 ⁽¹⁾	Addressing this location uses contents of FSR1H/FSR1L to address data memory (not a physical register)								xxxx xxxx	uuuu uuuu	
282h	PCL ⁽¹⁾	Program Counter (PC) Least Significant Byte								0000 0000	0000 0000	
283h	STATUS ⁽¹⁾	—	—	—	\overline{TO}	\overline{PD}	Z	DC	C	---1 1000	---q quuu	
284h	FSR0L ⁽¹⁾	Indirect Data Memory Address 0 Low Pointer								0000 0000	uuuu uuuu	
285h	FSR0H ⁽¹⁾	Indirect Data Memory Address 0 High Pointer								0000 0000	0000 0000	
286h	FSR1L ⁽¹⁾	Indirect Data Memory Address 1 Low Pointer								0000 0000	uuuu uuuu	
287h	FSR1H ⁽¹⁾	Indirect Data Memory Address 1 High Pointer								0000 0000	0000 0000	
288h	BSR ⁽¹⁾	—	—	—	BSR<4:0>					---0 0000	---0 0000	
289h	WREG ⁽¹⁾	Working Register								0000 0000	uuuu uuuu	
28Ah	PCLATH ⁽¹⁾	—	Write Buffer for the upper 7 bits of the Program Counter								-000 0000	-000 0000
28Bh	INTCON ⁽¹⁾	GIE	PEIE	TMR0IE	INTE	IOCFE	TMR0IF	INTF	IOCF	0000 0000	0000 0000	
28Ch	—	Unimplemented								—	—	
28Dh	—	Unimplemented								—	—	
28Eh	—	Unimplemented								—	—	
28Fh	—	Unimplemented								—	—	
290h	—	Unimplemented								—	—	
291h	—	Unimplemented								—	—	
292h	—	Unimplemented								—	—	
293h	—	Unimplemented								—	—	
294h	—	Unimplemented								—	—	
295h	—	Unimplemented								—	—	
296h	—	Unimplemented								—	—	
297h	—	Unimplemented								—	—	
298h	—	Unimplemented								—	—	
299h	—	Unimplemented								—	—	
29Ah	—	Unimplemented								—	—	
29Bh	—	Unimplemented								—	—	
29Ch	—	Unimplemented								—	—	
29Dh	—	Unimplemented								—	—	
29Eh	—	Unimplemented								—	—	
29Fh	—	Unimplemented								—	—	

Legend: x = unknown, u = unchanged, q = depends on condition, - = unimplemented, read as '0', r = reserved. Shaded locations unimplemented, read as '0'.

Note 1: These registers can be accessed from any bank.

2: PIC16LF1554.

3: PIC16LF1559.

4: These registers/bits are available at two address locations, in Bank 1 and Bank 14.

PIC16LF1554/1559

TABLE 3-9: SPECIAL FUNCTION REGISTER SUMMARY (CONTINUED)

Address	Name	Bit 7	Bit 6	Bit 5	Bit 4	Bit 3	Bit 2	Bit 1	Bit 0	Value on: POR, BOR	Value on all other Resets	
Bank 6												
300h	INDF0 ⁽¹⁾	Addressing this location uses contents of FSR0H/FSR0L to address data memory (not a physical register)								xxxx xxxx	uuuu uuuu	
301h	INDF1 ⁽¹⁾	Addressing this location uses contents of FSR1H/FSR1L to address data memory (not a physical register)								xxxx xxxx	uuuu uuuu	
302h	PCL ⁽¹⁾	Program Counter (PC) Least Significant Byte								0000 0000	0000 0000	
303h	STATUS ⁽¹⁾	—	—	—	\overline{TO}	\overline{PD}	Z	DC	C	---1 1000	---q quuu	
304h	FSR0L ⁽¹⁾	Indirect Data Memory Address 0 Low Pointer								0000 0000	uuuu uuuu	
305h	FSR0H ⁽¹⁾	Indirect Data Memory Address 0 High Pointer								0000 0000	0000 0000	
306h	FSR1L ⁽¹⁾	Indirect Data Memory Address 1 Low Pointer								0000 0000	uuuu uuuu	
307h	FSR1H ⁽¹⁾	Indirect Data Memory Address 1 High Pointer								0000 0000	0000 0000	
308h	BSR ⁽¹⁾	—	—	—	BSR<4:0>					---0 0000	---0 0000	
309h	WREG ⁽¹⁾	Working Register								0000 0000	uuuu uuuu	
30Ah	PCLATH ⁽¹⁾	—	Write Buffer for the upper 7 bits of the Program Counter								-000 0000	-000 0000
30Bh	INTCON ⁽¹⁾	GIE	PEIE	TMR0IE	INTE	IOCF	TMR0IF	INTF	IOCF	0000 0000	0000 0000	
30Ch	—	Unimplemented								—	—	
30Dh	—	Unimplemented								—	—	
30Eh	—	Unimplemented								—	—	
30Fh	—	Unimplemented								—	—	
310h	—	Unimplemented								—	—	
311h	—	Unimplemented								—	—	
312h	—	Unimplemented								—	—	
313h	—	Unimplemented								—	—	
314h	—	Unimplemented								—	—	
315h	—	Unimplemented								—	—	
316h	—	Unimplemented								—	—	
317h	—	Unimplemented								—	—	
318h	—	Unimplemented								—	—	
319h	—	Unimplemented								—	—	
31Ah	—	Unimplemented								—	—	
31Bh	—	Unimplemented								—	—	
31Ch	—	Unimplemented								—	—	
31Dh	—	Unimplemented								—	—	
31Eh	—	Unimplemented								—	—	
31Fh	—	Unimplemented								—	—	

Legend: x = unknown, u = unchanged, q = depends on condition, - = unimplemented, read as '0', r = reserved. Shaded locations unimplemented, read as '0'.

Note 1: These registers can be accessed from any bank.

2: PIC16LF1554.

3: PIC16LF1559.

4: These registers/bits are available at two address locations, in Bank 1 and Bank 14.

PIC16LF1554/1559

TABLE 3-9: SPECIAL FUNCTION REGISTER SUMMARY (CONTINUED)

Address	Name	Bit 7	Bit 6	Bit 5	Bit 4	Bit 3	Bit 2	Bit 1	Bit 0	Value on: POR, BOR	Value on all other Resets	
Bank 7												
380h	INDF0 ⁽¹⁾	Addressing this location uses contents of FSR0H/FSR0L to address data memory (not a physical register)								xxxx xxxx	uuuu uuuu	
381h	INDF1 ⁽¹⁾	Addressing this location uses contents of FSR1H/FSR1L to address data memory (not a physical register)								xxxx xxxx	uuuu uuuu	
382h	PCL ⁽¹⁾	Program Counter (PC) Least Significant Byte								0000 0000	0000 0000	
383h	STATUS ⁽¹⁾	—	—	—	\overline{TO}	\overline{PD}	Z	DC	C	---1 1000	---q quuu	
384h	FSR0L ⁽¹⁾	Indirect Data Memory Address 0 Low Pointer								0000 0000	uuuu uuuu	
385h	FSR0H ⁽¹⁾	Indirect Data Memory Address 0 High Pointer								0000 0000	0000 0000	
386h	FSR1L ⁽¹⁾	Indirect Data Memory Address 1 Low Pointer								0000 0000	uuuu uuuu	
387h	FSR1H ⁽¹⁾	Indirect Data Memory Address 1 High Pointer								0000 0000	0000 0000	
388h	BSR ⁽¹⁾	—	—	—	BSR<4:0>					---0 0000	---0 0000	
389h	WREG ⁽¹⁾	Working Register								0000 0000	uuuu uuuu	
38Ah	PCLATH ⁽¹⁾	—	Write Buffer for the upper 7 bits of the Program Counter								-000 0000	-000 0000
38Bh	INTCON ⁽¹⁾	GIE	PEIE	TMR0IE	INTE	IOCFIE	TMR0IF	INTF	IOCFIF	0000 0000	0000 0000	
38Ch	—	Unimplemented								—	—	
38Dh	—	Unimplemented								—	—	
38Eh	—	Unimplemented								—	—	
38Fh	—	Unimplemented								—	—	
390h	—	Unimplemented								—	—	
391h	IOCAP	—	—	IOCAP5	IOCAP4	IOCAP3	IOCAP2	IOCAP1	IOCAP0	--00 0000	--00 0000	
392h	IOCAN	—	—	IOCAN5	IOCAN4	IOCAN3	IOCAN2	IOCAN1	IOCAN0	--00 0000	--00 0000	
393h	IOCAF	—	—	IOCAF5	IOCAF4	IOCAF3	IOCAF2	IOCAF1	IOCAF0	--00 0000	--00 0000	
394h	IOCBP ⁽²⁾	Unimplemented								—	—	
	IOCBP ⁽³⁾	IOCBP7	IOCBP6	IOCBP5	IOCBP4	—	—	—	—	0000 ----	0000 ----	
395h	IOCBN ⁽²⁾	Unimplemented								—	—	
	IOCBN ⁽³⁾	IOCBN7	IOCBN6	IOCBN5	IOCBN4	—	—	—	—	0000 ----	0000 ----	
396h	IOCBF ⁽²⁾	Unimplemented								—	—	
	IOCBF ⁽³⁾	IOCBF7	IOCBF6	IOCBF5	IOCBF4	—	—	—	—	0000 ----	0000 ----	
397h	—	Unimplemented								—	—	
398h	—	Unimplemented								—	—	
399h	—	Unimplemented								—	—	
39Ah	—	Unimplemented								—	—	
39Bh	—	Unimplemented								—	—	
39Ch	—	Unimplemented								—	—	
39Dh	—	Unimplemented								—	—	
39Eh	—	Unimplemented								—	—	
39Fh	—	Unimplemented								—	—	

Legend: x = unknown, u = unchanged, q = depends on condition, - = unimplemented, read as '0', r = reserved. Shaded locations unimplemented, read as '0'.

Note 1: These registers can be accessed from any bank.

2: PIC16LF1554.

3: PIC16LF1559.

4: These registers/bits are available at two address locations, in Bank 1 and Bank 14.

PIC16LF1554/1559

TABLE 3-9: SPECIAL FUNCTION REGISTER SUMMARY (CONTINUED)

Address	Name	Bit 7	Bit 6	Bit 5	Bit 4	Bit 3	Bit 2	Bit 1	Bit 0	Value on: POR, BOR	Value on all other Resets	
Banks 8-11												
x00h/ x80h	INDF0 ⁽¹⁾	Addressing this location uses contents of FSR0H/FSR0L to address data memory (not a physical register)								xxxx xxxx	uuuu uuuu	
x00h/ x81h	INDF1 ⁽¹⁾	Addressing this location uses contents of FSR1H/FSR1L to address data memory (not a physical register)								xxxx xxxx	uuuu uuuu	
x02h/ x82h	PCL ⁽¹⁾	Program Counter (PC) Least Significant Byte								0000 0000	0000 0000	
x03h/ x83h	STATUS ⁽¹⁾	—	—	—	\overline{TO}	\overline{PD}	Z	DC	C	---1 1000	---q quuu	
x04h/ x84h	FSR0L ⁽¹⁾	Indirect Data Memory Address 0 Low Pointer								0000 0000	uuuu uuuu	
x05h/ x85h	FSR0H ⁽¹⁾	Indirect Data Memory Address 0 High Pointer								0000 0000	0000 0000	
x06h/ x86h	FSR1L ⁽¹⁾	Indirect Data Memory Address 1 Low Pointer								0000 0000	uuuu uuuu	
x07h/ x87h	FSR1H ⁽¹⁾	Indirect Data Memory Address 1 High Pointer								0000 0000	0000 0000	
x08h/ x88h	BSR ⁽¹⁾	—	—	—	BSR<4:0>				---	0 0000	---	0 0000
x09h/ x89h	WREG ⁽¹⁾	Working Register								0000 0000	uuuu uuuu	
x0Ah/ x8Ah	PCLATH ⁽¹⁾	—	Write Buffer for the upper 7 bits of the Program Counter								-000 0000	-000 0000
x0Bh/ x8Bh	INTCON ⁽¹⁾	GIE	PEIE	TMR0IE	INTE	IOCFIE	TMR0IF	INTF	IOCFIF	0000 000x	0000 000u	
x0Ch/ x8Ch — x1Fh/ x9Fh	—	Unimplemented								—	—	

Legend: x = unknown, u = unchanged, q = depends on condition, - = unimplemented, read as '0', r = reserved. Shaded locations unimplemented, read as '0'.

- Note**
- 1: These registers can be accessed from any bank.
 - 2: PIC16LF1554.
 - 3: PIC16LF1559.
 - 4: These registers/bits are available at two address locations, in Bank 1 and Bank 14.

PIC16LF1554/1559

TABLE 3-9: SPECIAL FUNCTION REGISTER SUMMARY (CONTINUED)

Address	Name	Bit 7	Bit 6	Bit 5	Bit 4	Bit 3	Bit 2	Bit 1	Bit 0	Value on: POR, BOR	Value on all other Resets	
Bank 12												
600h	INDF0 ⁽¹⁾	Addressing this location uses contents of FSR0H/FSR0L to address data memory (not a physical register)								xxxx xxxx	uuuu uuuu	
601h	INDF1 ⁽¹⁾	Addressing this location uses contents of FSR1H/FSR1L to address data memory (not a physical register)								xxxx xxxx	uuuu uuuu	
602h	PCL ⁽¹⁾	Program Counter (PC) Least Significant Byte								0000 0000	0000 0000	
603h	STATUS ⁽¹⁾	—	—	—	\overline{TO}	\overline{PD}	Z	DC	C	---1 1000	---q quuu	
604h	FSR0L ⁽¹⁾	Indirect Data Memory Address 0 Low Pointer								0000 0000	uuuu uuuu	
605h	FSR0H ⁽¹⁾	Indirect Data Memory Address 0 High Pointer								0000 0000	0000 0000	
606h	FSR1L ⁽¹⁾	Indirect Data Memory Address 1 Low Pointer								0000 0000	uuuu uuuu	
607h	FSR1H ⁽¹⁾	Indirect Data Memory Address 1 High Pointer								0000 0000	0000 0000	
608h	BSR ⁽¹⁾	—	—	—	BSR<4:0>					---0 0000	---0 0000	
609h	WREG ⁽¹⁾	Working Register								0000 0000	uuuu uuuu	
60Ah	PCLATH ⁽¹⁾	—	Write Buffer for the upper 7 bits of the Program Counter								-000 0000	-000 0000
60Bh	INTCON ⁽¹⁾	GIE	PEIE	TMR0IE	INTE	IOCFE	TMR0IF	INTF	IOCF	0000 0000	0000 0000	
60Ch	—	Unimplemented								—	—	
60Dh	—	Unimplemented								—	—	
60Eh	—	Unimplemented								—	—	
60Fh	—	Unimplemented								—	—	
610h	—	Unimplemented								—	—	
611h	PWM1DCL	PWM1DCL<7:6>		—	—	—	—	—	—	00-- ----	00-- ----	
612h	PWM1DCH	PWM 1 Duty Cycle Register (MSB) (PWM1DC<9:2>)								xxxx xxxx	uuuu uuuu	
613h	PWM1CON	PWM1EN	PWM1OE	PWM1OUT	PWM1POL	—	—	—	—	0000 ----	0000 ----	
614h	PWM2DCL	PWM2DCL<7:6>		—	—	—	—	—	—	00-- ----	00-- ----	
615h	PWM2DCH	PWM 2 Duty Cycle Register (MSB) (PWM2DC<9:2>)								xxxx xxxx	uuuu uuuu	
616h	PWM2CON	PWM2EN	PWM2OE	PWM2OUT	PWM2POL	—	—	—	—	0000 ----	0000 ----	
617h	—	Unimplemented								—	—	
618h	—	Unimplemented								—	—	
619h	—	Unimplemented								—	—	
61Ah	—	Unimplemented								—	—	
61Bh	—	Unimplemented								—	—	
61Ch	—	Unimplemented								—	—	
61Dh	—	Unimplemented								—	—	
61Eh	—	Unimplemented								—	—	
61Fh	—	Unimplemented								—	—	

Legend: x = unknown, u = unchanged, q = depends on condition, - = unimplemented, read as '0', r = reserved. Shaded locations unimplemented, read as '0'.

Note 1: These registers can be accessed from any bank.

2: PIC16LF1554.

3: PIC16LF1559.

4: These registers/bits are available at two address locations, in Bank 1 and Bank 14.

PIC16LF1554/1559

TABLE 3-9: SPECIAL FUNCTION REGISTER SUMMARY (CONTINUED)

Address	Name	Bit 7	Bit 6	Bit 5	Bit 4	Bit 3	Bit 2	Bit 1	Bit 0	Value on: POR, BOR	Value on all other Resets	
Banks 13												
x00h/ x80h	INDF0 ⁽¹⁾	Addressing this location uses contents of FSR0H/FSR0L to address data memory (not a physical register)								xxxx xxxx	uuuu uuuu	
x00h/ x81h	INDF1 ⁽¹⁾	Addressing this location uses contents of FSR1H/FSR1L to address data memory (not a physical register)								xxxx xxxx	uuuu uuuu	
x02h/ x82h	PCL ⁽¹⁾	Program Counter (PC) Least Significant Byte								0000 0000	0000 0000	
x03h/ x83h	STATUS ⁽¹⁾	—	—	—	\overline{TO}	\overline{PD}	Z	DC	C	---1 1000	---q quuu	
x04h/ x84h	FSR0L ⁽¹⁾	Indirect Data Memory Address 0 Low Pointer								0000 0000	uuuu uuuu	
x05h/ x85h	FSR0H ⁽¹⁾	Indirect Data Memory Address 0 High Pointer								0000 0000	0000 0000	
x06h/ x86h	FSR1L ⁽¹⁾	Indirect Data Memory Address 1 Low Pointer								0000 0000	uuuu uuuu	
x07h/ x87h	FSR1H ⁽¹⁾	Indirect Data Memory Address 1 High Pointer								0000 0000	0000 0000	
x08h/ x88h	BSR ⁽¹⁾	—	—	—	BSR<4:0>				---	0 0000	---	0 0000
x09h/ x89h	WREG ⁽¹⁾	Working Register								0000 0000	uuuu uuuu	
x0Ah/ x8Ah	PCLATH ⁽¹⁾	—	Write Buffer for the upper 7 bits of the Program Counter							-000 0000	-000 0000	
x0Bh/ x8Bh	INTCON ⁽¹⁾	GIE	PEIE	TMR0IE	INTE	IOCIE	TMR0IF	INTF	IOCIF	0000 000x	0000 000u	
x0Ch/ x8Ch — x1Fh/ x9Fh	—	Unimplemented								—	—	

Legend: x = unknown, u = unchanged, q = depends on condition, - = unimplemented, read as '0', r = reserved. Shaded locations unimplemented, read as '0'.

- Note**
- 1: These registers can be accessed from any bank.
 - 2: PIC16LF1554.
 - 3: PIC16LF1559.
 - 4: These registers/bits are available at two address locations, in Bank 1 and Bank 14.

PIC16LF1554/1559

TABLE 3-9: SPECIAL FUNCTION REGISTER SUMMARY (CONTINUED)

Address	Name	Bit 7	Bit 6	Bit 5	Bit 4	Bit 3	Bit 2	Bit 1	Bit 0	Value on: POR, BOR	Value on all other Resets	
Bank 14												
700h	INDF0 ⁽¹⁾	Addressing this location uses contents of FSR0H/FSR0L to address data memory (not a physical register)								xxxx xxxx	uuuu uuuu	
701h	INDF1 ⁽¹⁾	Addressing this location uses contents of FSR1H/FSR1L to address data memory (not a physical register)								xxxx xxxx	uuuu uuuu	
702h	PCL ⁽¹⁾	Program Counter (PC) Least Significant Byte								0000 0000	0000 0000	
703h	STATUS ⁽¹⁾	—	—	—	\overline{TO}	\overline{PD}	Z	DC	C	---1 1000	---q quuu	
704h	FSR0L ⁽¹⁾	Indirect Data Memory Address 0 Low Pointer								0000 0000	uuuu uuuu	
705h	FSR0H ⁽¹⁾	Indirect Data Memory Address 0 High Pointer								0000 0000	0000 0000	
706h	FSR1L ⁽¹⁾	Indirect Data Memory Address 1 Low Pointer								0000 0000	uuuu uuuu	
707h	FSR1H ⁽¹⁾	Indirect Data Memory Address 1 High Pointer								0000 0000	0000 0000	
708h	BSR ⁽¹⁾	—	—	—	BSR<4:0>			—	—	---0 0000	---0 0000	
709h	WREG ⁽¹⁾	Working Register								0000 0000	uuuu uuuu	
70Ah	PCLATH ⁽¹⁾	—	Write Buffer for the upper 7 bits of the Program Counter								-000 0000	-000 0000
70Bh	INTCON ⁽¹⁾	GIE	PEIE	TMR0IE	INTE	IOCFE	TMR0IF	INTF	IOCF	0000 000x	0000 000u	
70Ch	—	Unimplemented								—	—	
70Dh	—	Unimplemented								—	—	
70Eh	—	Unimplemented								—	—	
70Fh	—	Unimplemented								—	—	
710h	—	Unimplemented								—	—	
711h	AD1CON0/ AAD1CON0 ⁽⁴⁾	—	CHS14	CHS13	CHS12	CHS11	CHS10	GO/ \overline{DONE} 1	AD1ON	-000 0000	-000 0000	
712h	AADCON1/ ADCOMCON ⁽⁴⁾	ADFM	ADCS<2:0>			—	GO/ DONE_ALL	ADPREF<1:0>		0000 -000	0000 -000	
713h	AD1CON2/ AAD1CON2 ⁽⁴⁾	—	TRIGSEL1<2:0>			—	—	—	—	-000 ----	-000 ----	
714h	AAD1CON3	AD1EPPOL	AD1IPPOL	—	—	—	—	AD1IPEN	AD1DSEN	00-- --00	00-- --00	
715h	AADSTAT	—	AD2CONV	AD2STG<1:0>		—	AD1CONV	AD1STG<1:0>		-000 -000	-000 -000	
716h	AAD1PRE	—	AD1PRE<6:0>						—	—	-000 0000	-000 0000
717h	AAD1ACQ	—	AAD1ACQ<6:0>						—	—	-000 0000	-000 0000
718h	AAD1GRD	GRD1BOE	GRD1AOE	GRD1POL	—	—	—	—	—	000- ----	000- ----	
719h	AAD1CAP	—	—	—	—	ADD1CAP<3:0>			—	—	---- 0000	---- 0000
71Ah	AD1RES0L/ AAD1RES0L ⁽⁴⁾	ADC Result 0 Register Low								xxxx xxxx	uuuu uuuu	
71Bh	AD1RES0H/ AAD1RES0H ⁽⁴⁾	ADC Result 0 Register High								xxxx xxxx	uuuu uuuu	
71Ch	AD1RES1L/ AAD1RES1L	ADC Result 1 Register Low								xxxx xxxx	uuuu uuuu	
71Dh	AD1RES1H/ AAD1RES1H	ADC Result 1 Register High								xxxx xxxx	uuuu uuuu	
71Eh	AAD1CH ⁽²⁾	—	—	—	—	CH13	CH12	CH11	CH10	---- 0000	---- 0000	
	AAD1CH ⁽³⁾	—	CH16	CH15	CH14	CH13	CH12	CH11	CH10	-000 0000	-000 0000	
71Fh	—	Unimplemented								—	—	

Legend: x = unknown, u = unchanged, q = depends on condition, - = unimplemented, read as '0', r = reserved. Shaded locations unimplemented, read as '0'.

- Note**
- 1: These registers can be accessed from any bank.
 - 2: PIC16LF1554.
 - 3: PIC16LF1559.
 - 4: These registers/bits are available at two address locations, in Bank 1 and Bank 14.

PIC16LF1554/1559

TABLE 3-9: SPECIAL FUNCTION REGISTER SUMMARY (CONTINUED)

Address	Name	Bit 7	Bit 6	Bit 5	Bit 4	Bit 3	Bit 2	Bit 1	Bit 0	Value on: POR, BOR	Value on all other Resets	
Bank 15												
780h	INDF0 ⁽¹⁾	Addressing this location uses contents of FSR0H/FSR0L to address data memory (not a physical register)								xxxx xxxx	uuuu uuuu	
781h	INDF1 ⁽¹⁾	Addressing this location uses contents of FSR1H/FSR1L to address data memory (not a physical register)								xxxx xxxx	uuuu uuuu	
782h	PCL ⁽¹⁾	Program Counter (PC) Least Significant Byte								0000 0000	0000 0000	
783h	STATUS ⁽¹⁾	—	—	—	\overline{TO}	\overline{PD}	Z	DC	C	---1 1000	---q quuu	
784h	FSR0L ⁽¹⁾	Indirect Data Memory Address 0 Low Pointer								0000 0000	uuuu uuuu	
785h	FSR0H ⁽¹⁾	Indirect Data Memory Address 0 High Pointer								0000 0000	0000 0000	
786h	FSR1L ⁽¹⁾	Indirect Data Memory Address 1 Low Pointer								0000 0000	uuuu uuuu	
787h	FSR1H ⁽¹⁾	Indirect Data Memory Address 1 High Pointer								0000 0000	0000 0000	
788h	BSR ⁽¹⁾	—	—	—	BSR<4:0>			—	—	---0 0000	---0 0000	
789h	WREG ⁽¹⁾	Working Register								0000 0000	uuuu uuuu	
78Ah	PCLATH ⁽¹⁾	—	Write Buffer for the upper 7 bits of the Program Counter								-000 0000	-000 0000
78Bh	INTCON ⁽¹⁾	GIE	PEIE	TMR0IE	INTE	IOCF	TMR0IF	INTF	IOCF	0000 000x	0000 000u	
78Ch	—	Unimplemented								—	—	
78Dh	—	Unimplemented								—	—	
78Eh	—	Unimplemented								—	—	
78Fh	—	Unimplemented								—	—	
790h	—	Unimplemented								—	—	
791h	AD2CON0/ AAD2CON0	—	CHS24	CHS23	CHS22	CHS21	CHS20	$\overline{GO/DONE2}$	AD2ON	-000 0000	-000 0000	
792h	—	Unimplemented								—	—	
793h	AD2CON2/ AAD2CON2	—	TRIG2SEL1<2:0>			—	—	—	—	-000 ----	-000 ----	
794h	AAD2CON3	AD2EPPOL	AD2IPPOL	—	—	—	—	AD2IPEN	AD2DSEN	00-- --00	00-- --00	
795h	—	Unimplemented								—	—	
796h	AAD2PRE	—	AD2PRE<6:0>						—	—	-000 0000	-000 0000
797h	AAD2ACQ	—	AAD2ACQ<6:0>						—	—	-000 0000	-000 0000
798h	AAD2GRD	GRD2BOE	GRD2AOE	GRD2POL	—	—	—	—	—	000- ----	000- ----	
799h	AAD2CAP	—	—	—	—	ADD2CAP<3:0>			—	—	---- 0000	---- 0000
79Ah	AD2RES0L/ AAD2RES0L	ADC 2 Result 0 Register Low								xxxx xxxx	uuuu uuuu	
79Bh	AD2RES0H/ AAD2RES0H	ADC 2 Result 0 Register High								xxxx xxxx	uuuu uuuu	
79Ch	AD2RES1L/ AAD2RES1L	ADC 2 Result 1 Register Low								xxxx xxxx	uuuu uuuu	
79Dh	AD2RES1H/ AAD2RES1H	ADC 2 Result 1 Register High								xxxx xxxx	uuuu uuuu	
79Eh	AAD2CH ⁽²⁾	—	—	—	—	CH23	CH22	CH21	CH20	---- 0000	---- 0000	
	AAD2CH ⁽³⁾	—	CH26	CH25	CH24	CH23	CH22	CH21	CH20	-000 0000	-000 0000	
79Fh	—	Unimplemented								—	—	

Legend: x = unknown, u = unchanged, q = depends on condition, - = unimplemented, read as '0', r = reserved. Shaded locations unimplemented, read as '0'.

Note 1: These registers can be accessed from any bank.

2: PIC16LF1554.

3: PIC16LF1559.

4: These registers/bits are available at two address locations, in Bank 1 and Bank 14.

PIC16LF1554/1559

TABLE 3-9: SPECIAL FUNCTION REGISTER SUMMARY (CONTINUED)

Address	Name	Bit 7	Bit 6	Bit 5	Bit 4	Bit 3	Bit 2	Bit 1	Bit 0	Value on: POR, BOR	Value on all other Resets	
Banks 16-30												
x00h/ x80h	INDF0 ⁽¹⁾	Addressing this location uses contents of FSR0H/FSR0L to address data memory (not a physical register)								xxxx xxxx	uuuu uuuu	
x00h/ x81h	INDF1 ⁽¹⁾	Addressing this location uses contents of FSR1H/FSR1L to address data memory (not a physical register)								xxxx xxxx	uuuu uuuu	
x02h/ x82h	PCL ⁽¹⁾	Program Counter (PC) Least Significant Byte								0000 0000	0000 0000	
x03h/ x83h	STATUS ⁽¹⁾	—	—	—	\overline{TO}	\overline{PD}	Z	DC	C	---1 1000	---q quuu	
x04h/ x84h	FSR0L ⁽¹⁾	Indirect Data Memory Address 0 Low Pointer								0000 0000	uuuu uuuu	
x05h/ x85h	FSR0H ⁽¹⁾	Indirect Data Memory Address 0 High Pointer								0000 0000	0000 0000	
x06h/ x86h	FSR1L ⁽¹⁾	Indirect Data Memory Address 1 Low Pointer								0000 0000	uuuu uuuu	
x07h/ x87h	FSR1H ⁽¹⁾	Indirect Data Memory Address 1 High Pointer								0000 0000	0000 0000	
x08h/ x88h	BSR ⁽¹⁾	—	—	—	BSR<4:0>					---0 0000	---0 0000	
x09h/ x89h	WREG ⁽¹⁾	Working Register								0000 0000	uuuu uuuu	
x0Ah/ x8Ah	PCLATH ⁽¹⁾	—	Write Buffer for the upper 7 bits of the Program Counter								-000 0000	-000 0000
x0Bh/ x8Bh	INTCON ⁽¹⁾	GIE	PEIE	TMR0IE	INTE	IOCF	TMR0IF	INTF	IOCF	0000 0000	0000 0000	

Legend: x = unknown, u = unchanged, q = depends on condition, - = unimplemented, read as '0', r = reserved. Shaded locations unimplemented, read as '0'.

Note 1: These registers can be accessed from any bank.

2: PIC16LF1554.

3: PIC16LF1559.

4: These registers/bits are available at two address locations, in Bank 1 and Bank 14.

PIC16LF1554/1559

TABLE 3-9: SPECIAL FUNCTION REGISTER SUMMARY (CONTINUED)

Address	Name	Bit 7	Bit 6	Bit 5	Bit 4	Bit 3	Bit 2	Bit 1	Bit 0	Value on: POR, BOR	Value on all other Resets	
Bank 31												
F80h	INDF0 ⁽¹⁾	Addressing this location uses contents of FSR0H/FSR0L to address data memory (not a physical register)								xxxx xxxx	uuuu uuuu	
F81h	INDF1 ⁽¹⁾	Addressing this location uses contents of FSR1H/FSR1L to address data memory (not a physical register)								xxxx xxxx	uuuu uuuu	
F82h	PCL ⁽¹⁾	Program Counter (PC) Least Significant Byte								0000 0000	0000 0000	
F83h	STATUS ⁽¹⁾	—	—	—	\overline{TO}	\overline{PD}	Z	DC	C	---1 1000	---q quuu	
F84h	FSR0L ⁽¹⁾	Indirect Data Memory Address 0 Low Pointer								0000 0000	uuuu uuuu	
F85h	FSR0H ⁽¹⁾	Indirect Data Memory Address 0 High Pointer								0000 0000	0000 0000	
F86h	FSR1L ⁽¹⁾	Indirect Data Memory Address 1 Low Pointer								0000 0000	uuuu uuuu	
F87h	FSR1H ⁽¹⁾	Indirect Data Memory Address 1 High Pointer								0000 0000	0000 0000	
F88h	BSR ⁽¹⁾	—	—	—	BSR<4:0>			—	—	---0 0000	---0 0000	
F89h	WREG ⁽¹⁾	Working Register								0000 0000	uuuu uuuu	
F8Ah	PCLATH ⁽¹⁾	—	Write Buffer for the upper 7 bits of the Program Counter								-000 0000	-000 0000
F8Bh	INTCON ⁽¹⁾	GIE	PEIE	TMR0IE	INTE	IOCF	TMR0IF	INTF	IOCF	0000 0000	0000 0000	
F8Ch	—	Unimplemented								—	—	
FE2h	—	Unimplemented								—	—	
FE3h	—	Unimplemented								—	—	
FE4h	STATUS_-SHAD	—	—	—	—	—	Z	DC	C	---- -xxx	---- -uuu	
FE5h	WREG_SHAD	Working Register Normal (Non-ICD) Shadow								xxxx xxxx	uuuu uuuu	
FE6h	BSR_SHAD	—	—	—	Bank Select Register Normal (Non-ICD) Shadow			—	—	---x xxxx	---u uuuu	
FE7h	PCLATH_-SHAD	—	Program Counter Latch High Register Normal (Non-ICD) Shadow								-xxx xxxx	uuuu uuuu
FE8h	FSR0L_SHAD	Indirect Data Memory Address 0 Low Pointer Normal (Non-ICD) Shadow								xxxx xxxx	uuuu uuuu	
FE9h	FSR0H_SHAD	Indirect Data Memory Address 0 High Pointer Normal (Non-ICD) Shadow								xxxx xxxx	uuuu uuuu	
FEAh	FSR1L_SHAD	Indirect Data Memory Address 1 Low Pointer Normal (Non-ICD) Shadow								xxxx xxxx	uuuu uuuu	
FEBh	FSR1H_SHAD	Indirect Data Memory Address 1 High Pointer Normal (Non-ICD) Shadow								xxxx xxxx	uuuu uuuu	
FECh	—	Unimplemented								—	—	
FEDh	STKPTR	—	—	—	Current Stack pointer			—	—	---1 1111	---1 1111	
FEEh	TOSL	Top of Stack Low byte								xxxx xxxx	uuuu uuuu	
FEFh	TOSH	—	Top of Stack High byte								-xxx xxxx	-uuu uuuu

Legend: x = unknown, u = unchanged, q = depends on condition, - = unimplemented, read as '0', r = reserved. Shaded locations unimplemented, read as '0'.

- Note**
- 1: These registers can be accessed from any bank.
 - 2: PIC16LF1554.
 - 3: PIC16LF1559.
 - 4: These registers/bits are available at two address locations, in Bank 1 and Bank 14.

3.3 PCL and PCLATH

The Program Counter (PC) is 15 bits wide. The low byte comes from the PCL register, which is a readable and writable register. The high byte (PC<14:8>) is not directly readable or writable and comes from PCLATH. On any Reset, the PC is cleared. Figure 3-4 shows the five situations for the loading of the PC.

FIGURE 3-4: LOADING OF PC IN DIFFERENT SITUATIONS

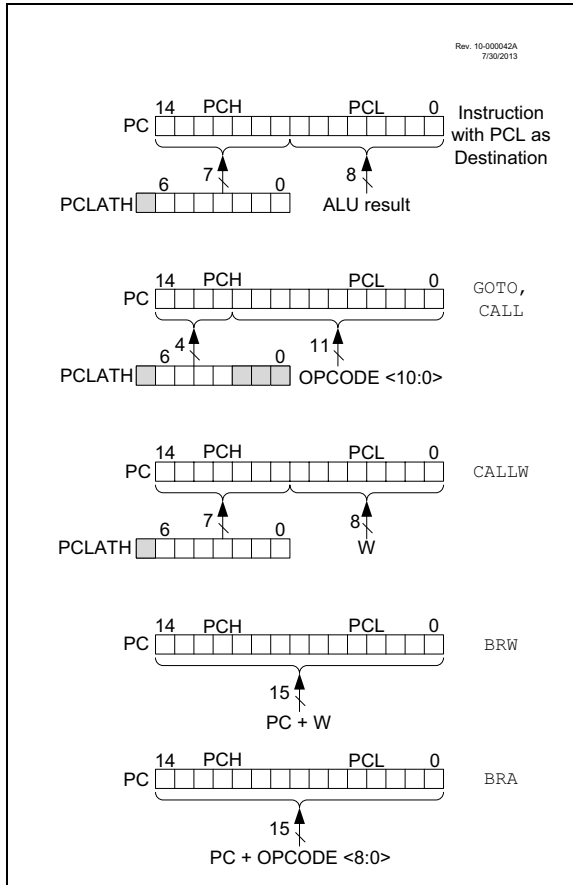

3.3.1 MODIFYING PCL

Executing any instruction with the PCL register as the destination simultaneously causes the Program Counter PC<14:8> bits (PCH) to be replaced by the contents of the PCLATH register. This allows the entire contents of the program counter to be changed by writing the desired upper seven bits to the PCLATH register. When the lower eight bits are written to the PCL register, all 15 bits of the program counter will change to the values contained in the PCLATH register and those being written to the PCL register.

3.3.2 COMPUTED GOTO

A computed GOTO is accomplished by adding an offset to the program counter (ADDWF PCL). When performing a table read using a computed GOTO method, care should be exercised if the table location crosses a PCL memory boundary (each 256-byte block). Refer to Application Note AN556, "Implementing a Table Read" (DS00556).

3.3.3 COMPUTED FUNCTION CALLS

A computed function CALL allows programs to maintain tables of functions and provide another way to execute state machines or look-up tables. When performing a table read using a computed function CALL, care should be exercised if the table location crosses a PCL memory boundary (each 256-byte block).

If using the CALL instruction, the PCH<2:0> and PCL registers are loaded with the operand of the CALL instruction. PCH<6:3> is loaded with PCLATH<6:3>.

The CALLW instruction enables computed calls by combining PCLATH and W to form the destination address. A computed CALLW is accomplished by loading the W register with the desired address and executing CALLW. The PCL register is loaded with the value of W and PCH is loaded with PCLATH.

3.3.4 BRANCHING

The branching instructions add an offset to the PC. This allows relocatable code and code that crosses page boundaries. There are two forms of branching, BRW and BRA. The PC will have incremented to fetch the next instruction in both cases. When using either branching instruction, a PCL memory boundary may be crossed.

If using BRW, load the W register with the desired unsigned address and execute BRW. The entire PC will be loaded with the address PC + 1 + W.

If using BRA, the entire PC will be loaded with PC + 1 + the signed value of the operand of the BRA instruction.

PIC16LF1554/1559

3.4 Stack

All devices have a 16-level x 15-bit wide hardware stack (refer to [Figure 3-5](#) through [Figure 3-8](#)). The stack space is not part of either program or data space. The PC is PUSHed onto the stack when `CALL` or `CALLW` instructions are executed or an interrupt causes a branch. The stack is POPed in the event of a `RETURN`, `RETLW` or a `RETFIE` instruction execution. `PCLATH` is not affected by a `PUSH` or `POP` operation.

The stack operates as a circular buffer if the `STVREN` bit is programmed to '0' (Configuration Words). This means that after the stack has been PUSHed sixteen times, the seventeenth PUSH overwrites the value that was stored from the first PUSH. The eighteenth PUSH overwrites the second PUSH (and so on). The `STKOVF` and `STKUNF` flag bits will be set on an Overflow/Underflow, regardless of whether the Reset is enabled.

Note 1: There are no instructions/mnemonics called `PUSH` or `POP`. These are actions that occur from the execution of the `CALL`, `CALLW`, `RETURN`, `RETLW` and `RETFIE` instructions or the vectoring to an interrupt address.

3.4.1 ACCESSING THE STACK

The stack is available through the `TOSH`, `TOSL` and `STKPTR` registers. `STKPTR` is the current value of the Stack Pointer. `TOSH:TOSL` register pair points to the TOP of the stack. Both registers are read/writable. `TOS` is split into `TOSH` and `TOSL` due to the 15-bit size of the PC. To access the stack, adjust the value of `STKPTR`, which will position `TOSH:TOSL`, then read/write to `TOSH:TOSL`. `STKPTR` is 5 bits to allow detection of overflow and underflow.

Note: Care should be taken when modifying the `STKPTR` while interrupts are enabled.

During normal program operation, `CALL`, `CALLW` and Interrupts will increment `STKPTR` while `RETLW`, `RETURN`, and `RETFIE` will decrement `STKPTR`. At any time `STKPTR` can be inspected to see how much stack is left. The `STKPTR` always points at the currently used place on the stack. Therefore, a `CALL` or `CALLW` will increment the `STKPTR` and then write the PC, and a return will unload the PC and then decrement the `STKPTR`.

Reference [Figure 3-5](#) through [Figure 3-8](#) for examples of accessing the stack.

FIGURE 3-5: ACCESSING THE STACK EXAMPLE 1

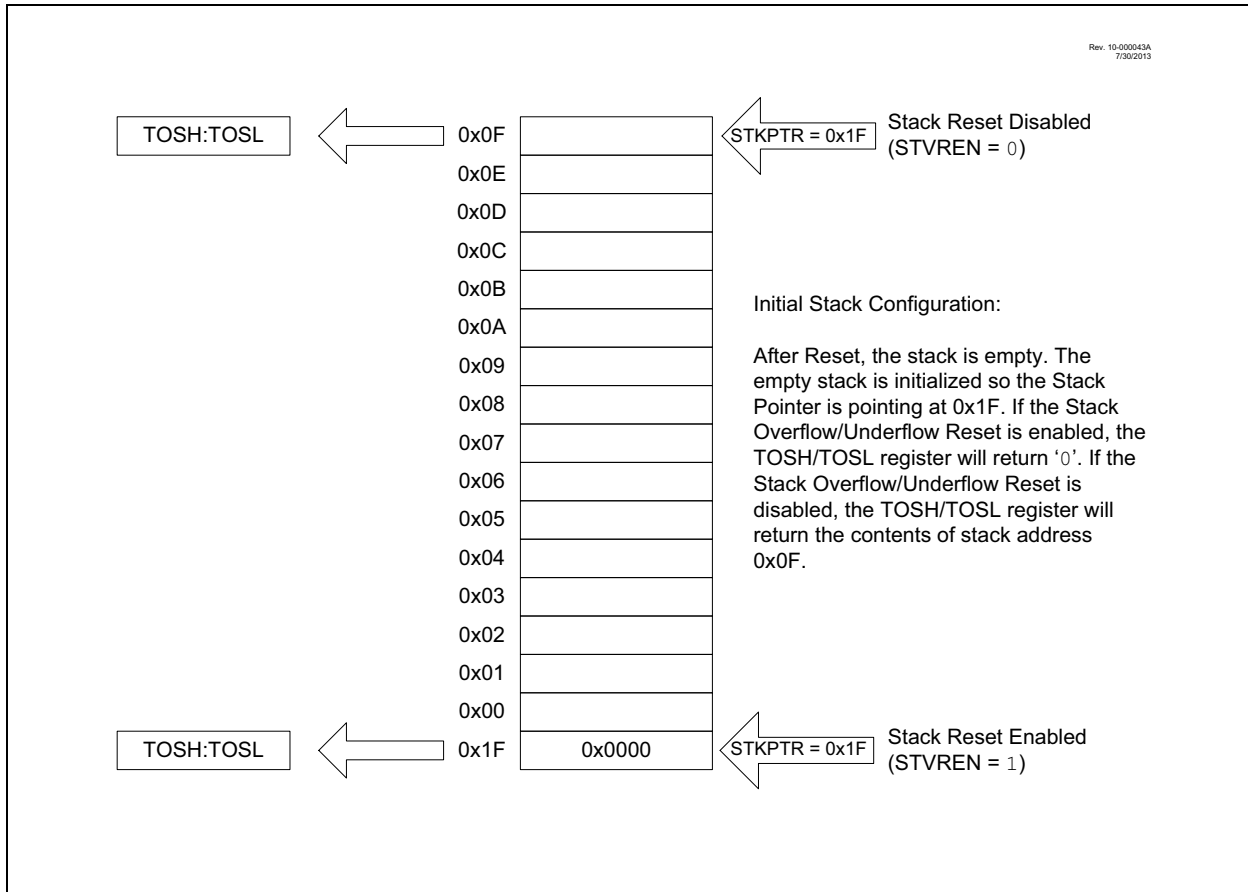

FIGURE 3-6: ACCESSING THE STACK EXAMPLE 2

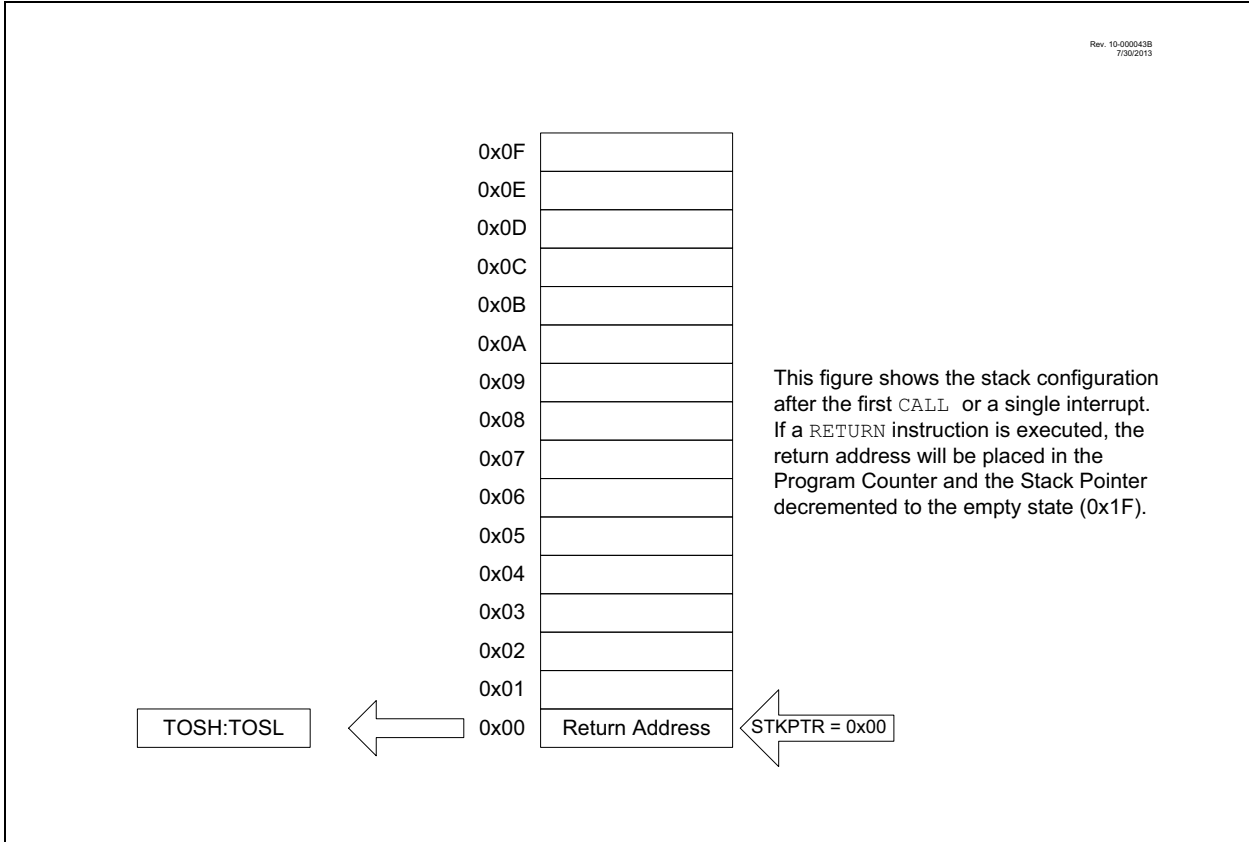
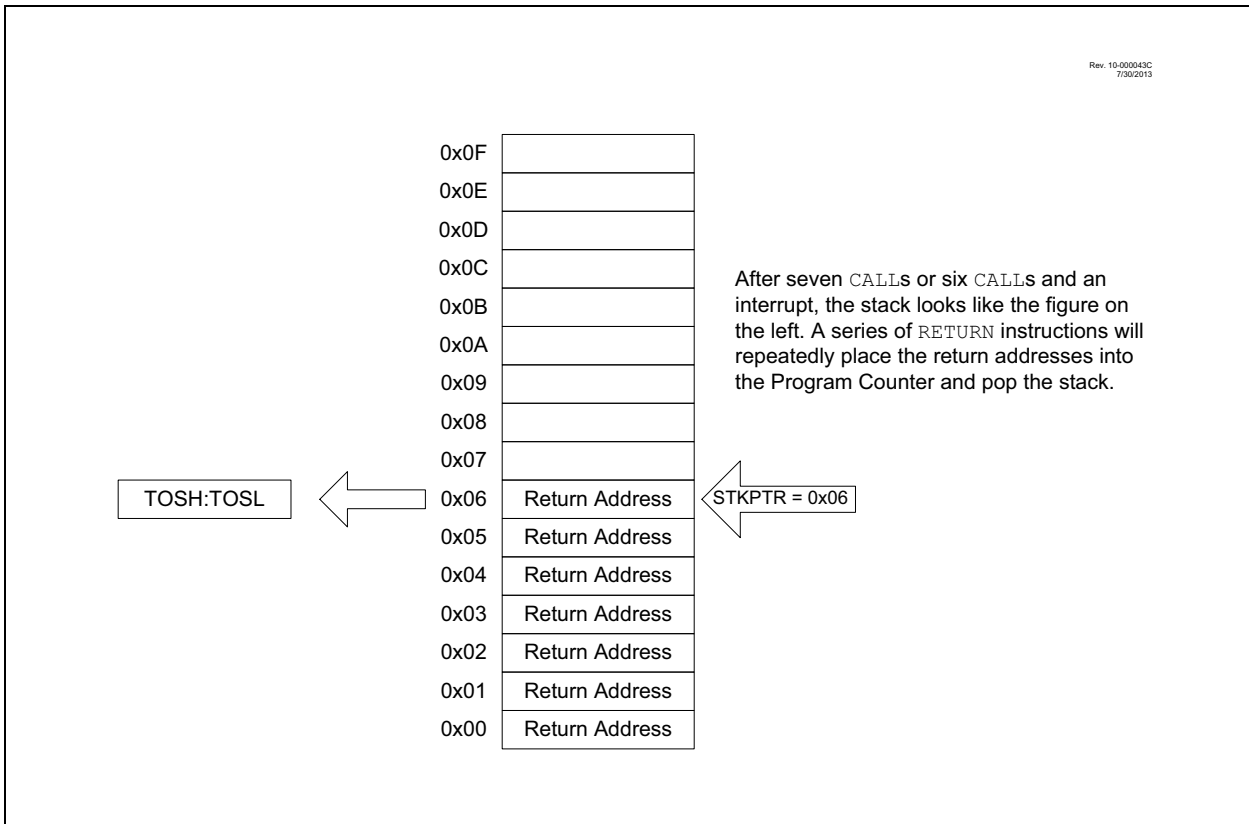
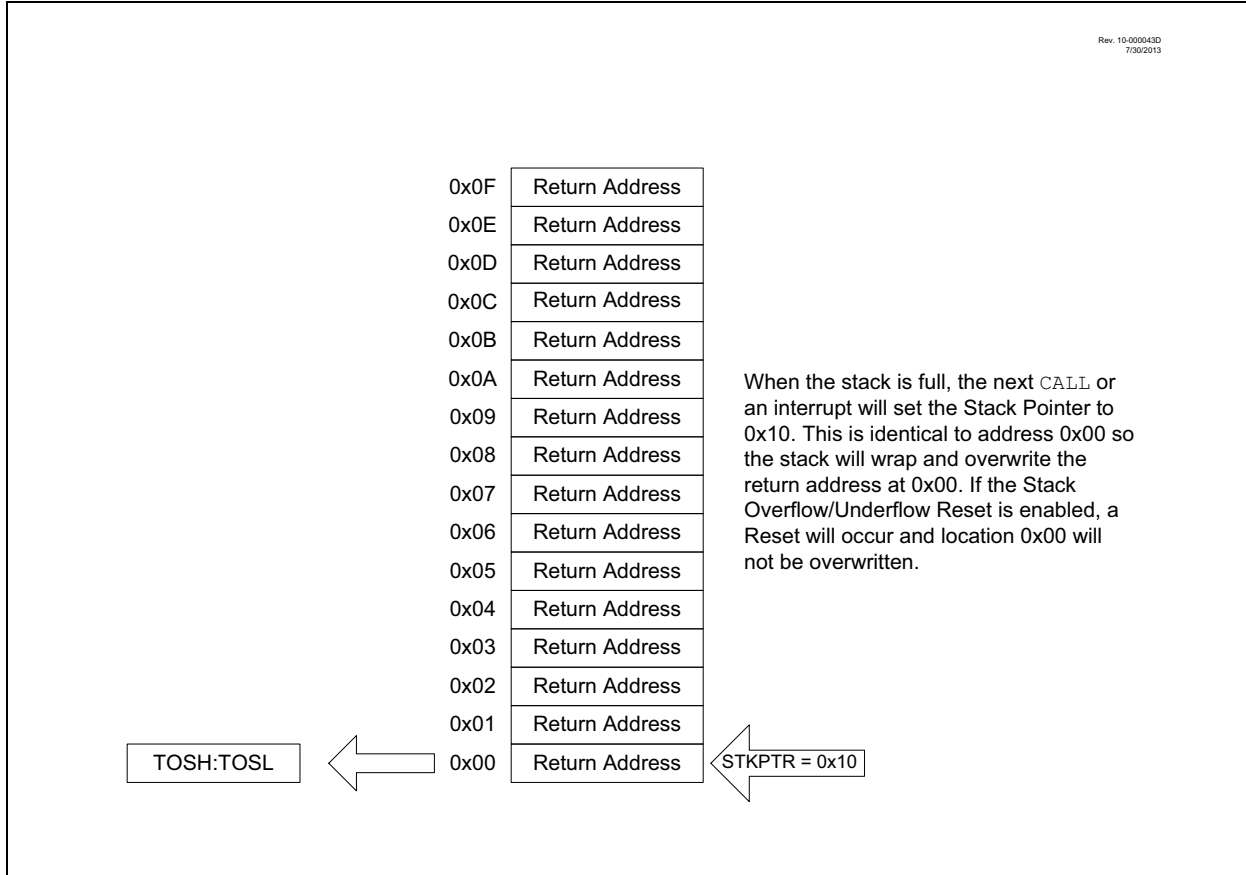

FIGURE 3-7: ACCESSING THE STACK EXAMPLE 3



PIC16LF1554/1559

FIGURE 3-8: ACCESSING THE STACK EXAMPLE 4



3.4.2 OVERFLOW/UNDERFLOW RESET

If the STVREN bit in Configuration Words is programmed to '1', the device will be reset if the stack is PUSHed beyond the sixteenth level or POPed beyond the first level, setting the appropriate bits (STKOVF or STKUNF, respectively) in the PCON register.

3.5 Indirect Addressing

The INDFn registers are not physical registers. Any instruction that accesses an INDFn register actually accesses the register at the address specified by the File Select Registers (FSR). If the FSRn address specifies one of the two INDFn registers, the read will return '0' and the write will not occur (though Status bits may be affected). The FSRn register value is created by the pair FSRnH and FSRnL.

The FSR registers form a 16-bit address that allows an addressing space with 65536 locations. These locations are divided into three memory regions:

- Traditional Data Memory
- Linear Data Memory
- Program Flash Memory

FIGURE 3-9: INDIRECT ADDRESSING

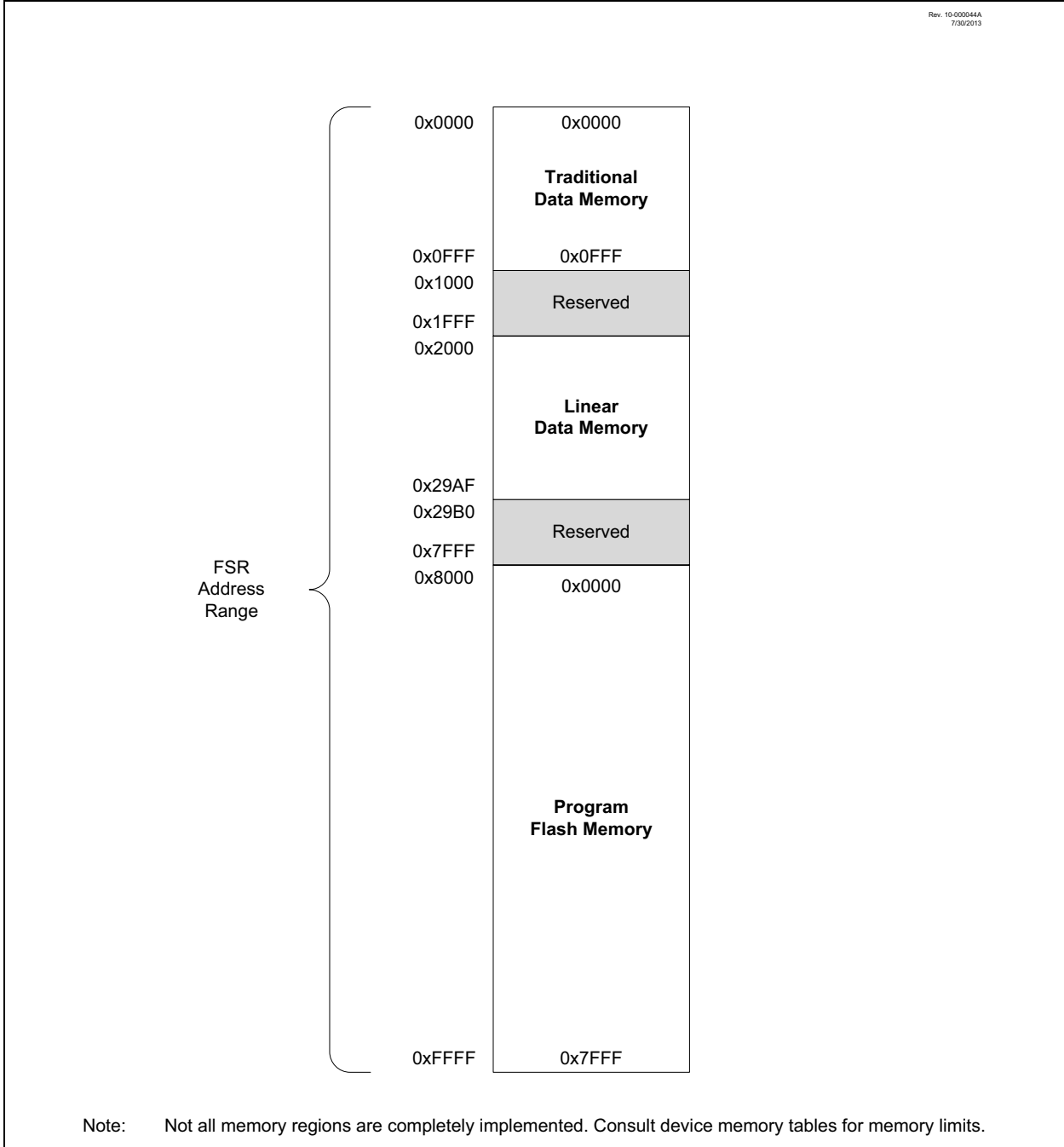

PIC16LF1554/1559

3.5.1 TRADITIONAL DATA MEMORY

The traditional data memory is a region from FSR address 0x000 to FSR address 0xFFF. The addresses correspond to the absolute addresses of all SFR, GPR and common registers.

FIGURE 3-10: TRADITIONAL DATA MEMORY MAP

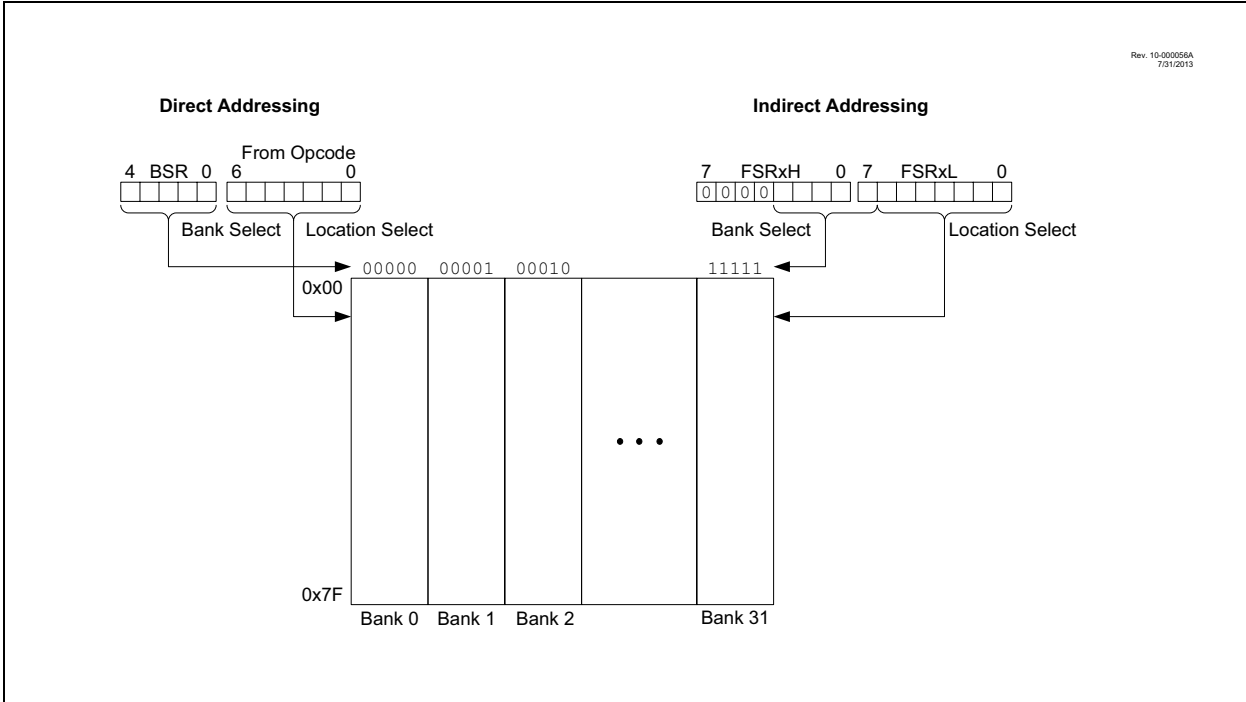

3.5.2 LINEAR DATA MEMORY

The linear data memory is the region from FSR address 0x2000 to FSR address 0x29AF. This region is a virtual region that points back to the 80-byte blocks of GPR memory in all the banks.

Unimplemented memory reads as 0x00. Use of the linear data memory region allows buffers to be larger than 80 bytes because incrementing the FSR beyond one bank will go directly to the GPR memory of the next bank.

The 16 bytes of common memory are not included in the linear data memory region.

FIGURE 3-11: LINEAR DATA MEMORY MAP

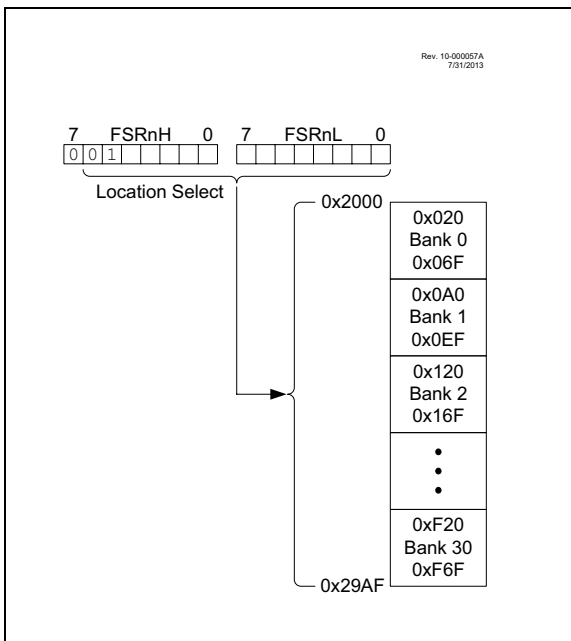

3.5.3 PROGRAM FLASH MEMORY

To make constant data access easier, the entire program Flash memory is mapped to the upper half of the FSR address space. When the MSb of FSRnH is set, the lower 15 bits are the address in program memory which will be accessed through INDF. Only the lower eight bits of each memory location is accessible via INDF. Writing to the program Flash memory cannot be accomplished via the FSR/INDF interface. All instructions that access program Flash memory via the FSR/INDF interface will require one additional instruction cycle to complete.

FIGURE 3-12: PROGRAM FLASH MEMORY MAP

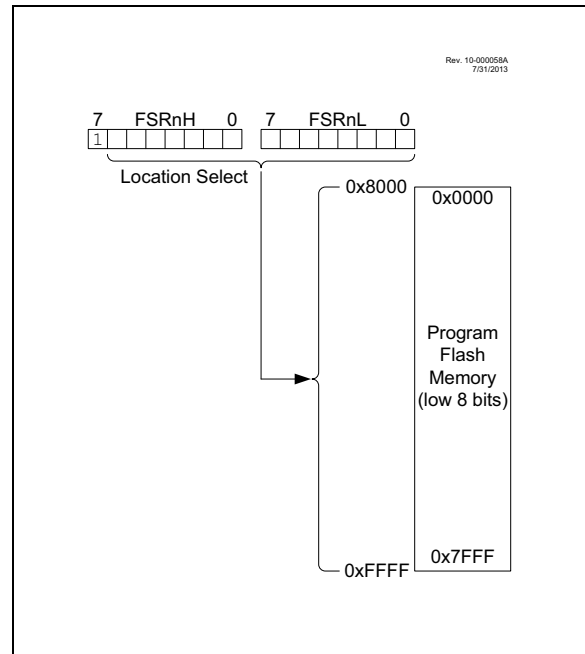

PIC16LF1554/1559

4.0 DEVICE CONFIGURATION

Device configuration consists of Configuration Words, Code Protection and Device ID.

4.1 Configuration Words

There are several Configuration Word bits that allow different oscillator and memory protection options. These are implemented as Configuration Word 1 at 8007h and Configuration Word 2 at 8008h.

Note: The $\overline{\text{DEBUG}}$ bit in Configuration Words is managed automatically by device development tools including debuggers and programmers. For normal device operation, this bit should be maintained as a '1'.

4.2 Register Definitions: Configuration Words

REGISTER 4-1: CONFIG1: CONFIGURATION WORD 1

U-1	U-1	R/P-1	R/P-1	R/P-1	U-1
—	—	CLKOUTEN	BOREN<1:0>		—
bit 13					bit 8

R/P-1	R/P-1	R/P-1	R/P-1	R/P-1	U-1	R/P-1	R/P-1
CP	MCLRE	PWRTE	WDTE<1:0>		—	FOSC<1:0>	
bit 7							bit 0

Legend:

R = Readable bit P = Programmable bit U = Unimplemented bit, read as '1'
 '0' = Bit is cleared '1' = Bit is set -n = Value when blank or after Bulk Erase

bit 13-12 **Unimplemented:** Read as '1'

bit 11 **CLKOUTEN:** Clock Out Enable bit
 1 = CLKOUT function is disabled. I/O function on the CLKOUT pin
 0 = CLKOUT function is enabled on the CLKOUT pin

bit 10-9 **BOREN<1:0>:** Brown-Out Reset Enable bits⁽¹⁾
 11 = BOR enabled
 10 = BOR enabled during operation and disabled in Sleep
 01 = BOR controlled by SBOREN bit of the BORCON register
 00 = BOR disabled

bit 8 **Unimplemented:** Read as '1'

bit 7 **CP:** Code Protection bit⁽²⁾
 1 = Program memory code protection is disabled
 0 = Program memory code protection is enabled

bit 6 **MCLRE:** MCLR/VPP Pin Function Select bit
If LVP bit = 1:
 This bit is ignored.
If LVP bit = 0:
 1 = MCLR/VPP pin function is MCLR; Weak pull-up enabled.
 0 = MCLR/VPP pin function is digital input; MCLR internally disabled; Weak pull-up under control of WPUA3 bit.

bit 5 **PWRTE:** Power-Up Timer Enable bit
 1 = PWRT disabled
 0 = PWRT enabled

bit 4-3 **WDTE<1:0>:** Watchdog Timer Enable bits
 11 = WDT enabled
 10 = WDT enabled while running and disabled in Sleep
 01 = WDT controlled by the SWDTEN bit in the WDTCON register
 00 = WDT disabled

bit 2 **Unimplemented:** Read as '1'

bit 1-0 **FOSC<1:0>:** Oscillator Selection bits
 11 = ECH: External Clock, High-Power mode: on CLKIN pin
 10 = ECM: External Clock, Medium-Power mode: on CLKIN pin
 01 = ECL: External Clock, Low-Power mode: on CLKIN pin
 00 = INTOSC oscillator: I/O function on CLKIN

- Note 1:** Enabling Brown-out Reset does not automatically enable Power-up Timer.
Note 2: Once enabled, code-protect can only be disabled by bulk erasing the device.

PIC16LF1554/1559

REGISTER 4-2: CONFIG2: CONFIGURATION WORD 2

R/P-1	R/P-1	R/P-1	R/P-1	R/P-1	U-1
LVP	$\overline{\text{DEBUG}}$	$\overline{\text{LPBOR}}$	BORV	STVREN	—
bit 13					bit 8

U-1	U-1	U-1	U-1	U-1	U-1	R/P-1	R/P-1
—	—	—	—	—	—	WRT<1:0>	
bit 7						bit 0	

Legend:

R = Readable bit P = Programmable bit U = Unimplemented bit, read as '1'
 '0' = Bit is cleared '1' = Bit is set -n = Value when blank or after Bulk Erase

- bit 13 **LVP:** Low-Voltage Programming Enable bit⁽¹⁾
 1 = Low-voltage programming enabled
 0 = High-voltage on MCLR must be used for programming
- bit 12 **DEBUG:** In-Circuit Debugger Mode bit⁽²⁾
 1 = In-Circuit Debugger disabled, ICSPCLK and ICSPDAT are general purpose I/O pins
 0 = In-Circuit Debugger enabled, ICSPCLK and ICSPDAT are dedicated to the debugger
- bit 11 **LPBOR:** Low-Power BOR Enable bit
 1 = Low-Power Brown-out Reset is disabled
 0 = Low-Power Brown-out Reset is enabled
- bit 10 **BORV:** Brown-Out Reset Voltage Selection bit⁽³⁾
 1 = Brown-out Reset voltage (V_{BOR}), low trip point selected
 0 = Brown-out Reset voltage (V_{BOR}), high trip point selected
- bit 9 **STVREN:** Stack Overflow/Underflow Reset Enable bit
 1 = Stack Overflow or Underflow will cause a Reset
 0 = Stack Overflow or Underflow will not cause a Reset
- bit 8-2 **Unimplemented:** Read as '1'
- bit 1-0 **WRT<1:0>:** Flash Memory Self-Write Protection bits
 4 kW Flash memory (PIC16LF1554 only)
 11 = Write protection off
 10 = 000h to 1FFh write protected, 200h to FFFh may be modified
 01 = 000h to 7FFh write protected, 800h to FFFh may be modified
 00 = 000h to FFFh write protected, no addresses may be modified
 8 kW Flash memory (PIC16LF1559 only)
 11 = Write protection off
 10 = 000h to 01FFh write protected, 0200h to 1FFFh may be modified
 01 = 000h to 0FFFh write protected, 1000h to 1FFFh may be modified
 00 = 000h to 1FFFh write protected, no addresses may be modified

- Note 1:** The LVP bit cannot be programmed to '0' when Programming mode is entered via LVP.
Note 2: The DEBUG bit in Configuration Words is managed automatically by device development tools including debuggers and programmers. For normal device operation, this bit should be maintained as a '1'.
Note 3: See V_{BOR} parameter for specific trip point voltages.

4.3 Code Protection

Code protection allows the device to be protected from unauthorized access. Internal access to the program memory is unaffected by any code protection setting.

4.3.1 PROGRAM MEMORY PROTECTION

The entire program memory space is protected from external reads and writes by the \overline{CP} bit in Configuration Words. When $\overline{CP} = 0$, external reads and writes of program memory are inhibited and a read will return all '0's. The CPU can continue to read program memory, regardless of the protection bit settings. Writing the program memory is dependent upon the write protection setting. See [Section 4.4 "Write Protection"](#) for more information.

4.4 Write Protection

Write protection allows the device to be protected from unintended self-writes. Applications, such as bootloader software, can be protected while allowing other regions of the program memory to be modified.

The WRT<1:0> bits in Configuration Words define the size of the program memory block that is protected.

4.7 Register Definitions: Device ID

REGISTER 4-3: DEVID: DEVICE ID REGISTER

R	R	R	R	R	R
DEV<8:3>					
bit 13			bit 8		

R	R	R	R	R	R	R	R
DEV<2:0>			REV<4:0>				
bit 7			bit 0				

Legend:

R = Readable bit

'1' = Bit is set

'0' = Bit is cleared

bit 13-5 **DEV<8:0>**: Device ID bits

Device	DEVID<13:0> Values	
	DEV<8:0>	REV<4:0>
PIC16LF1554	0010 1111 000	x xxxx
PIC16LF1559	0010 1111 001	x xxxx

bit 4-0 **REV<4:0>**: Revision ID bits

These bits are used to identify the revision (see Table above under DEV<8:0>).

4.5 User ID

Four memory locations (8000h-8003h) are designated as ID locations where the user can store checksum or other code identification numbers. These locations are readable and writable during normal execution. See [Section 10.4 "User ID, Device ID and Configuration Word Access"](#) for more information on accessing these memory locations. For more information on checksum calculation, see the "*PIC16LF1554/1559 Memory Programming Specification*" (DS40001743).

4.6 Device ID and Revision ID

The memory location 8006h is where the Device ID and Revision ID are stored. The upper nine bits hold the Device ID. The lower five bits hold the Revision ID. See [Section 10.4 "User ID, Device ID and Configuration Word Access"](#) for more information on accessing these memory locations.

Development tools, such as device programmers and debuggers, may be used to read the Device ID and Revision ID.

PIC16LF1554/1559

5.0 OSCILLATOR MODULE

5.1 Overview

The oscillator module has a wide variety of clock sources and selection features that allow it to be used in a wide range of applications while maximizing performance and minimizing power consumption. Figure 5-1 illustrates a block diagram of the oscillator module.

Clock sources can be supplied from external clock oscillators. In addition, the system clock source can be supplied from one of two internal oscillators and PLL circuits, with a choice of speeds selectable via software. Additional clock features include:

- Selectable system clock source between external or internal sources via software.

The oscillator module can be configured in one of the following clock modes.

1. ECL – External Clock Low-Power mode (0 MHz to 0.5 MHz)
2. ECM – External Clock Medium-Power mode (0.5 MHz to 4 MHz)
3. ECH – External Clock High-Power mode (4 MHz to 20 MHz)
4. INTOSC – Internal oscillator (31 kHz to 32 MHz)

Clock source modes are selected by the FOSC<1:0> bits in the Configuration Words. The FOSC bits determine the type of oscillator that will be used when the device is first powered.

The EC clock mode relies on an external logic level signal as the device clock source.

The INTOSC internal oscillator block produces low and high-frequency clock sources, designated LFINTOSC and HFINTOSC (see Internal Oscillator Block, Figure 5-1). A wide selection of device clock frequencies may be derived from these clock sources.

FIGURE 5-1: SIMPLIFIED PIC® MCU CLOCK SOURCE BLOCK DIAGRAM

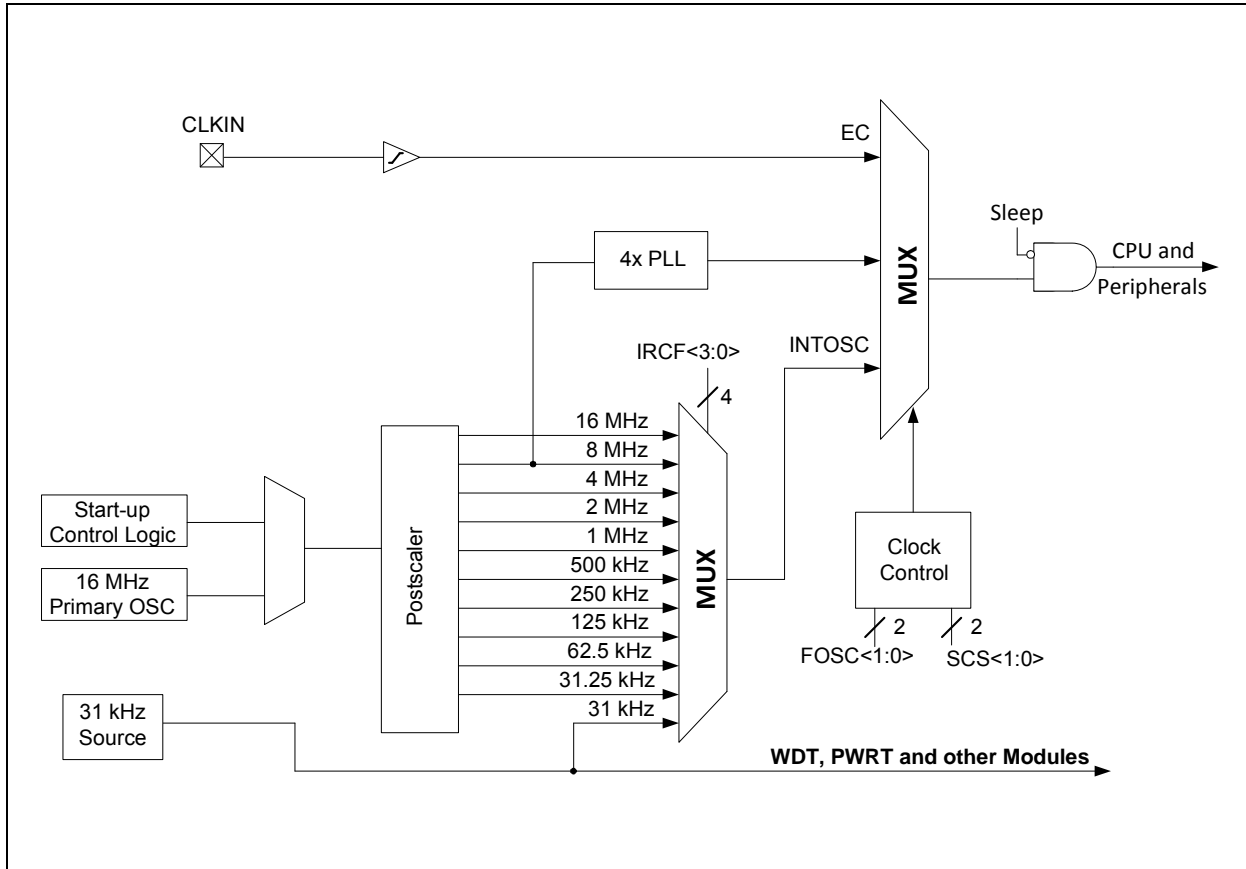

5.2 Clock Source Types

Clock sources can be classified as external or internal.

External clock sources rely on external circuitry for the clock source to function. Examples are: oscillator modules (EC mode).

Internal clock sources are contained within the oscillator module. The oscillator block has two internal oscillators that are used to generate two system clock sources: the 16 MHz High-Frequency Internal Oscillator (HFINTOSC) and the 31 kHz Low-Frequency Internal Oscillator (LFINTOSC).

The system clock can be selected between external or internal clock sources via the System Clock Select (SCS) bits in the OSCCON register. See [Section 5.3 “Clock Switching”](#) for additional information.

5.2.1 EXTERNAL CLOCK SOURCES

An external clock source can be used as the device system clock by performing one of the following actions:

- Program the FOSC<1:0> bits in the Configuration Words to select an external clock source that will be used as the default system clock upon a device Reset.
- Clear the SCS<1:0> bits in the OSCCON register to switch the system clock source to:
 - An external clock source determined by the value of the FOSC bits.

See [Section 5.3 “Clock Switching”](#) for more information.

5.2.1.1 EC Mode

The External Clock (EC) mode allows an externally generated logic level signal to be the system clock source. When operating in this mode, an external clock source is connected to the CLKIN input. CLKOUT is available for general purpose I/O or CLKOUT. [Figure 5-2](#) shows the pin connections for EC mode.

EC mode has three power modes to select from through Configuration Words:

- High power, 4-20 MHz (FOSC = 11)
- Medium power, 0.5-4 MHz (FOSC = 10)
- Low power, 0-0.5 MHz (FOSC = 01)

When EC mode is selected, there is no delay in operation after a Power-on Reset (POR) or wake-up from Sleep. Because the PIC® MCU design is fully static, stopping the external clock input will have the effect of halting the device while leaving all data intact. Upon restarting the external clock, the device will resume operation as if no time had elapsed.

FIGURE 5-2: EXTERNAL CLOCK (EC) MODE OPERATION

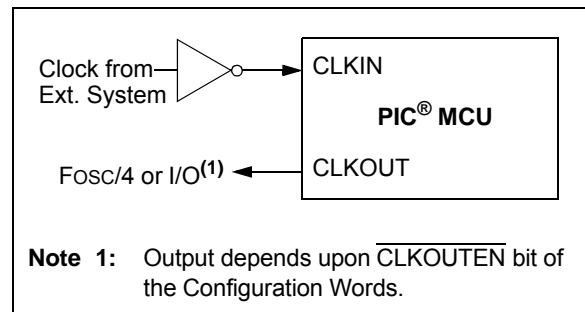

PIC16LF1554/1559

5.2.2 INTERNAL CLOCK SOURCES

The device may be configured to use the internal oscillator block as the system clock by performing either of the following actions:

- Program the FOSC<1:0> bits in Configuration Words to select the INTOSC clock source, which will be used as the default system clock upon a device Reset.
- Set the SCS<1:0> bits in the OSCCON register to '1x' to switch the system clock source to the internal oscillator during run-time. See [Section 5.3 "Clock Switching"](#) for more information.

In INTOSC mode, the CLKIN pin is available for general purpose I/O. The CLKOUT pin is available for general purpose I/O or CLKOUT.

The function of the CLKOUT pin is determined by the CLKOUTEN bit in Configuration Words.

The internal oscillator block has two independent oscillators.

1. The HFINTOSC (High-Frequency Internal Oscillator) is factory calibrated and operates at 16 MHz.
2. The LFINTOSC (Low-Frequency Internal Oscillator) is uncalibrated and operates at 31 kHz.

5.2.2.1 HFINTOSC

The High-Frequency Internal Oscillator (HFINTOSC) is a factory calibrated 16 MHz internal clock source.

The outputs of the HFINTOSC connects to a prescaler and multiplexer (see [Figure 5-1](#)). One of multiple frequencies derived from the HFINTOSC can be selected via software using the IRCF<3:0> bits of the OSCCON register. See [Section 5.2.2.4 "Internal Oscillator Clock Switch Timing"](#) for more information.

The HFINTOSC is enabled by:

- Configure the IRCF<3:0> bits of the OSCCON register for the desired HF frequency, and
- FOSC<1:0> = 00, or
- Set the System Clock Source (SCS) bits of the OSCCON register to '1x'.

A fast start-up oscillator allows internal circuits to power-up and stabilize before switching to HFINTOSC.

The High-Frequency Internal Oscillator Ready bit (HFIOFR) of the OSCSTAT register indicates when the HFINTOSC is running.

The High-Frequency Internal Oscillator Stable bit (HFIOFS) of the OSCSTAT register indicates when the HFINTOSC is running within 0.5% of its final value.

5.2.2.2 LFINTOSC

The Low-Frequency Internal Oscillator (LFINTOSC) is an uncalibrated 31 kHz internal clock source.

The output of the LFINTOSC connects to a multiplexer (see [Figure 5-1](#)). Select 31 kHz, via software, using the IRCF<3:0> bits of the OSCCON register. See [Section 5.2.2.4 "Internal Oscillator Clock Switch Timing"](#) for more information. The LFINTOSC is also the source for the Power-up Timer (PWRT) and Watchdog Timer (WDT).

The LFINTOSC is enabled by selecting 31 kHz (IRCF<3:0> bits of the OSCCON register = 000x) as the system clock source (SCS bits of the OSCCON register = 1x), or when any of the following are enabled:

- Configure the IRCF<3:0> bits of the OSCCON register for the LF frequency, and
- FOSC<1:0> = 00, or
- Set the System Clock Source (SCS) bits of the OSCCON register to '1x'

Peripherals that use the LFINTOSC are:

- Power-up Timer (PWRT)
- Watchdog Timer (WDT)

The Low-Frequency Internal Oscillator Ready bit (LFIOFR) of the OSCSTAT register indicates when the LFINTOSC is running.

5.2.2.3 Internal Oscillator Frequency Selection

The system clock speed can be selected via software using the Internal Oscillator Frequency Select bits IRCF<3:0> of the OSCCON register.

The outputs of the 16 MHz HFINTOSC postscaler and the LFINTOSC connect to a multiplexer (see [Figure 5-1](#)). The Internal Oscillator Frequency Select bits IRCF<3:0> of the OSCCON register select the frequency. One of the following frequencies can be selected via software:

- 32 MHz (requires 4x PLL)
- 16 MHz
- 8 MHz
- 4 MHz
- 2 MHz
- 1 MHz
- 500 kHz (default after Reset)
- 250 kHz
- 125 kHz
- 62.5 kHz
- 31.25 kHz
- 31 kHz (LFINTOSC)

Note: Following any Reset, the IRCF<3:0> bits of the OSCCON register are set to '0111' and the frequency selection is set to 500 kHz. The user can modify the IRCF bits to select a different frequency.

The IRCF<3:0> bits of the OSCCON register allow duplicate selections for some frequencies. These duplicate choices can offer system design trade-offs. Lower power consumption can be obtained when changing oscillator sources for a given frequency. Faster transition times can be obtained between frequency changes that use the same oscillator source.

5.2.2.4 Internal Oscillator Clock Switch Timing

When switching between the HFINTOSC and the LFINTOSC, the new oscillator may already be shut down to save power (see [Figure 5-3](#)). If this is the case, there is a delay after the IRCF<3:0> bits of the OSCCON register are modified before the frequency selection takes place. The OSCSTAT register will reflect the current active status of the HFINTOSC and LFINTOSC oscillators. The sequence of a frequency selection is as follows:

1. IRCF<3:0> bits of the OSCCON register are modified.
2. If the new clock is shut down, a clock start-up delay is started.
3. Clock switch circuitry waits for a falling edge of the current clock.
4. Clock switch is complete.

See [Figure 5-3](#) for more details.

If the internal oscillator speed is switched between two clocks of the same source, there is no start-up delay before the new frequency is selected.

Start-up delay specifications are located in the oscillator tables of [Section 25.0 "Electrical Specifications"](#).

5.2.2.5 32 MHz Internal Oscillator Frequency Selection

The Internal Oscillator Block can be used with the 4x PLL to produce a 32 MHz internal system clock source. The following settings are required to use the 32 MHz internal clock source:

- The FOSC bits in Configuration Word 1 must be set to use the INTOSC source as the device system clock (FOSC<1:0> = 00).
- The SCS bits in the OSCCON register must be cleared to use the clock determined by FOSC<1:0> in Configuration Word 1 (SCS<1:0> = 00).
- The IRCF bits in the OSCCON register must be set to the 8 MHz HFINTOSC set to use (IRCF<3:0> = 1110).
- The SPLLEN bit in the OSCCON register must be set to enable the 4x PLL.

The 4x PLL is not available for use with the internal oscillator when the SCS bits of the OSCCON register are set to '1x'. The SCS bits must be set to '00' to use the 4x PLL with the internal oscillator.

PIC16LF1554/1559

FIGURE 5-3: INTERNAL OSCILLATOR SWITCH TIMING

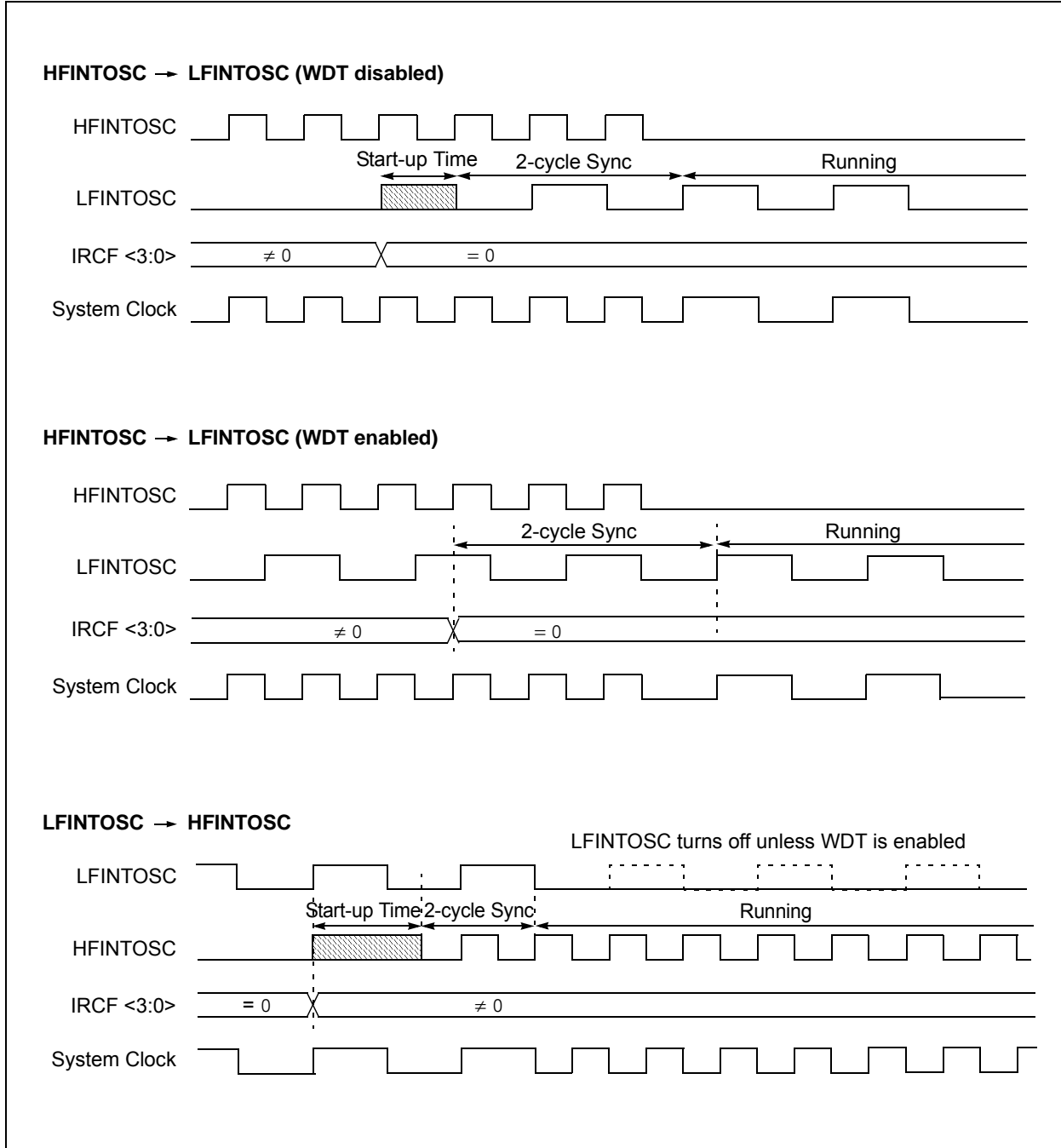

5.3 Clock Switching

The system clock source can be switched between external and internal clock sources via software using the System Clock Select (SCS) bits of the OSCCON register. The following clock sources can be selected using the SCS bits:

- Default system oscillator determined by FOSC bits in Configuration Words
- Internal Oscillator Block (INTOSC)

5.3.1 SYSTEM CLOCK SELECT (SCS) BITS

The System Clock Select (SCS) bits of the OSCCON register selects the system clock source that is used for the CPU and peripherals.

- When the SCS bits of the OSCCON register = 00, the system clock source is determined by value of the FOSC<1:0> bits in the Configuration Words.
- When the SCS bits of the OSCCON register = 1x, the system clock source is chosen by the internal oscillator frequency selected by the IRCF<3:0> bits of the OSCCON register. After a Reset, the SCS bits of the OSCCON register are always cleared.

When switching between clock sources, a delay is required to allow the new clock to stabilize. These oscillator delays are shown in [Table 5-1](#).

TABLE 5-1: OSCILLATOR SWITCHING DELAYS

Switch From	Switch To	Frequency	Oscillator Delay
Sleep/POR	LFINTOSC	31 kHz	2 cycles
	HFINTOSC	31.25 kHz-32 MHz	
	EC	DC – 20 MHz	
LFINTOSC	EC	DC – 20 MHz	1 cycle of each
Any clock source	HFINTOSC	31.25 kHz-16 MHz	2 μ s (approx.)
Any clock source	LFINTOSC	31 kHz	1 cycle of each

PIC16LF1554/1559

5.4 Register Definitions: Oscillator Control

REGISTER 5-1: OSCCON: OSCILLATOR CONTROL REGISTER

R/W-0/0	R/W-0/0	R/W-1/1	R/W-1/1	R/W-1/1	U-0	R/W-0/0	R/W-0/0
SPLLEN	IRCF<3:0>			—	SCS<1:0>		
bit 7							bit 0

Legend:

R = Readable bit	W = Writable bit	U = Unimplemented bit, read as '0'
u = Bit is unchanged	x = Bit is unknown	-n/n = Value at POR and BOR/Value at all other Resets
'1' = Bit is set	'0' = Bit is cleared	

bit 7 **SPLLEN:** Software PLL Enable bit
 1 = 4x PLL Is enabled
 0 = 4x PLL is disabled

bit 6-3 **IRCF<3:0>:** Internal Oscillator Frequency Select bits
 1111 = 16 MHz
 1110 = 8 MHz
 1101 = 4 MHz
 1100 = 2 MHz
 1011 = 1 MHz
 1010 = 500 kHz⁽¹⁾
 1001 = 250 kHz⁽¹⁾
 1000 = 125 kHz⁽¹⁾
 0111 = 500 kHz (default upon Reset)
 0110 = 250 kHz
 0101 = 125 kHz
 0100 = 62.5 kHz
 001x = 31.25 kHz
 000x = 31 kHz (LFINTOSC)

bit 2 **Unimplemented:** Read as '0'

bit 1-0 **SCS<1:0>:** System Clock Select bits
 1x = Internal oscillator block
 01 = Reserved
 00 = Clock determined by FOSC<1:0> in Configuration Words

Note 1: Duplicate frequency derived from HFINTOSC.

REGISTER 5-2: OSCSTAT: OSCILLATOR STATUS REGISTER

U-0	R-0/q	U-0	R-0/q	U-0	U-0	R-0/q	R-0/q
—	PLLSR	—	HFIOFR	—	—	LFIOFR	HFIOFS
bit 7							bit 0

Legend:

R = Readable bit	W = Writable bit	U = Unimplemented bit, read as '0'
u = Bit is unchanged	x = Bit is unknown	-n/n = Value at POR and BOR/Value at all other Resets
'1' = Bit is set	'0' = Bit is cleared	q = Conditional

bit 7	Unimplemented: Read as '0'
bit 6	PLLSR: 4x PLL Ready bit 1 = 4x PLL is ready 0 = 4x PLL is not ready
bit 5	Unimplemented: Read as '0'
bit 4	HFIOFR: High-Frequency Internal Oscillator Ready bit 1 = 16 MHz Internal Oscillator (HFINTOSC) is ready 0 = 16 MHz Internal Oscillator (HFINTOSC) is not ready
bit 3-2	Unimplemented: Read as '0'
bit 1	LFIOFR: Low-Frequency Internal Oscillator Ready bit 1 = 31 kHz Internal Oscillator (LFINTOSC) is ready 0 = 31 kHz Internal Oscillator (LFINTOSC) is not ready
bit 0	HFIOFS: High-Frequency Internal Oscillator Stable bit 1 = 16 MHz Internal Oscillator (HFINTOSC) is stable 0 = 16 MHz Internal Oscillator (HFINTOSC) is not yet stable

TABLE 5-2: SUMMARY OF REGISTERS ASSOCIATED WITH CLOCK SOURCES

Name	Bit 7	Bit 6	Bit 5	Bit 4	Bit 3	Bit 2	Bit 1	Bit 0	Register on Page
OSCCON	SPLLEN	IRCF<3:0>			—	SCS<1:0>		62	
OSCSTAT	—	PLLSR	—	HFIOFR	—	—	LFIOFR	HFIOFS	63

Legend: — = unimplemented location, read as '0'. Shaded cells are not used by clock sources.

TABLE 5-3: SUMMARY OF CONFIGURATION WORD WITH CLOCK SOURCES

Name	Bits	Bit -/7	Bit -/6	Bit 13/5	Bit 12/4	Bit 11/3	Bit 10/2	Bit 9/1	Bit 8/0	Register on Page
CONFIG1	13:8	—	—	—	—	CLKOUTEN	BOREN<1:0>		—	53
	7:0	\overline{CP}	MCLRE	\overline{PWRTE}	WDTE<1:0>		—	FOSC<1:0>		

Legend: — = unimplemented location, read as '0'. Shaded cells are not used by clock sources.

PIC16LF1554/1559

6.0 RESETS

There are multiple ways to reset this device:

- Power-On Reset (POR)
- Brown-Out Reset (BOR)
- Low-Power Brown-Out Reset (LPBOR)
- MCLR Reset
- WDT Reset
- RESET instruction
- Stack Overflow
- Stack Underflow
- Programming mode exit

To allow VDD to stabilize, an optional Power-up Timer can be enabled to extend the Reset time after a BOR or POR event.

A simplified block diagram of the on-chip Reset circuit is shown in [Figure 6-1](#).

FIGURE 6-1: SIMPLIFIED BLOCK DIAGRAM OF ON-CHIP RESET CIRCUIT

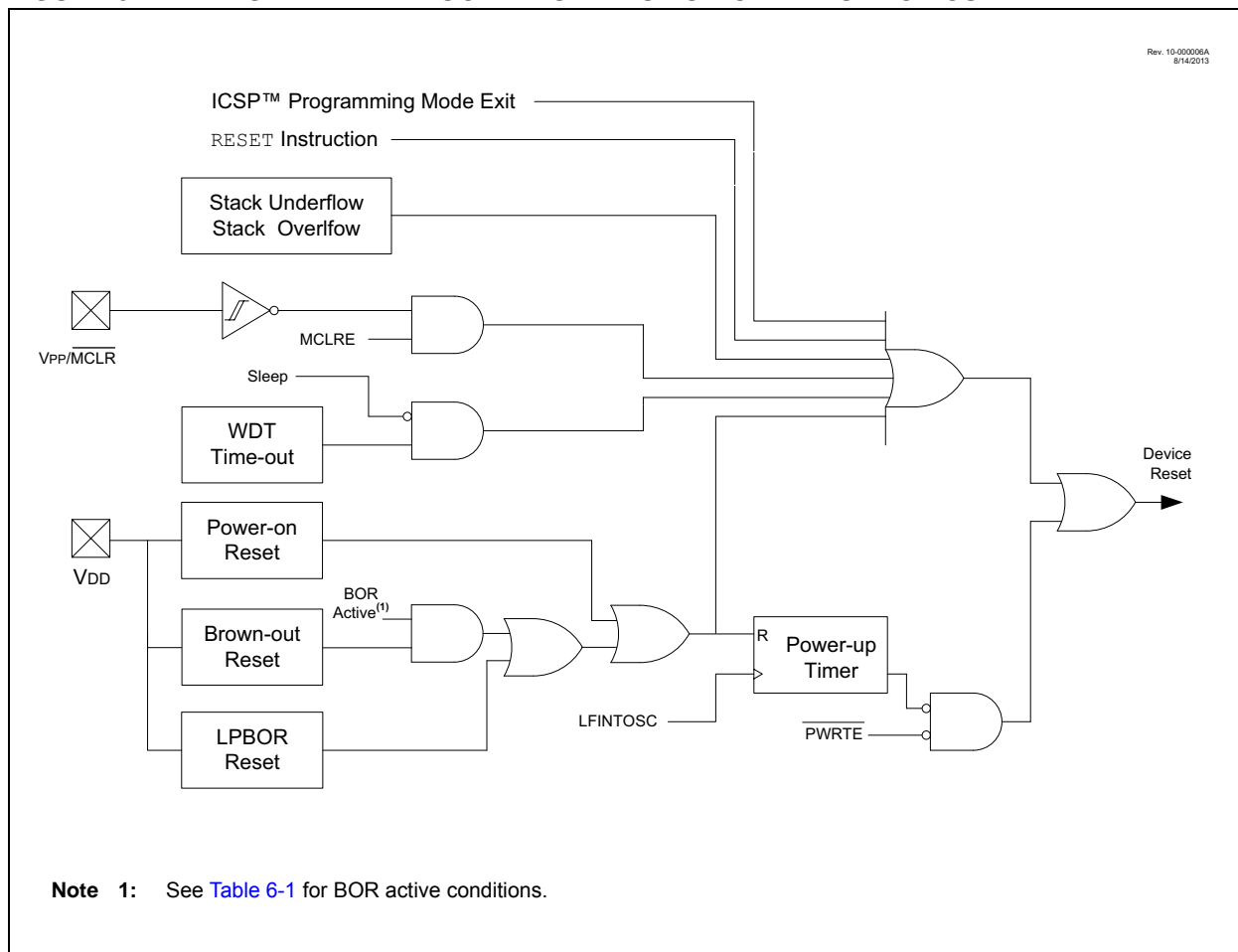

6.1 Power-on Reset (POR)

The POR circuit holds the device in Reset until VDD has reached an acceptable level for minimum operation. Slow rising VDD, fast operating speeds or analog performance may require greater than minimum VDD. The PWRT, BOR or MCLR features can be used to extend the start-up period until all device operation conditions have been met.

6.1.1 POWER-UP TIMER (PWRT)

The Power-up Timer provides a nominal 64 ms time-out on POR or Brown-out Reset.

The device is held in Reset as long as PWRT is active. The PWRT delay allows additional time for the VDD to rise to an acceptable level. The Power-up Timer is enabled by clearing the PWRTEN bit in Configuration Words.

The Power-up Timer starts after the release of the POR and BOR.

For additional information, refer to Application Note AN607, "Power-up Trouble Shooting" (DS00000607).

6.2 Brown-out Reset (BOR)

The BOR circuit holds the device in Reset when VDD reaches a selectable minimum level. Between the POR and BOR, complete voltage range coverage for execution protection can be implemented.

The Brown-out Reset module has four operating modes controlled by the BOREN<1:0> bits in Configuration Words. The four operating modes are:

- BOR is always on
- BOR is off when in Sleep
- BOR is controlled by software
- BOR is always off

Refer to [Table 6-1](#) for more information.

The Brown-out Reset voltage level is selectable by configuring the BORV bit in Configuration Words.

A VDD noise rejection filter prevents the BOR from triggering on small events. If VDD falls below VBOR for a duration greater than parameter TBORDC, the device will reset. See [Figure 6-2](#) for more information.

TABLE 6-1: BOR OPERATING MODES

BOREN<1:0>	SBOREN	Device Mode	BOR Mode	Instruction Execution upon: Release of POR or Wake-up from Sleep
11	X	X	Active	Waits for BOR ready ⁽¹⁾ (BORRDY = 1)
10	X	Awake	Active	Waits for BOR ready (BORRDY = 1)
		Sleep	Disabled	
01	1	X	Active	Waits for BOR ready ⁽¹⁾ (BORRDY = 1)
	0	X	Disabled	Begins immediately (BORRDY = x)
00	X	X	Disabled	

Note 1: In these specific cases, "release of POR" and "wake-up from Sleep," there is no delay in start-up. The BOR ready flag, (BORRDY = 1), will be set before the CPU is ready to execute instructions because the BOR circuit is forced on by the BOREN<1:0> bits.

6.2.1 BOR IS ALWAYS ON

When the BOREN bits of Configuration Words are programmed to '11', the BOR is always on. The device start-up will be delayed until the BOR is ready and VDD is higher than the BOR threshold.

BOR protection is active during Sleep. The BOR does not delay wake-up from Sleep.

6.2.2 BOR IS OFF IN SLEEP

When the BOREN bits of Configuration Words are programmed to '10', the BOR is on, except in Sleep. The device start-up will be delayed until the BOR is ready and VDD is higher than the BOR threshold.

BOR protection is not active during Sleep. The device wake-up will be delayed until the BOR is ready.

6.2.3 BOR CONTROLLED BY SOFTWARE

When the BOREN bits of Configuration Words are programmed to '01', the BOR is controlled by the SBOREN bit of the BORCON register. The device start-up is not delayed by the BOR ready condition or the VDD level.

BOR protection begins as soon as the BOR circuit is ready. The status of the BOR circuit is reflected in the BORRDY bit of the BORCON register.

BOR protection is unchanged by Sleep.

PIC16LF1554/1559

FIGURE 6-2: BROWN-OUT SITUATIONS

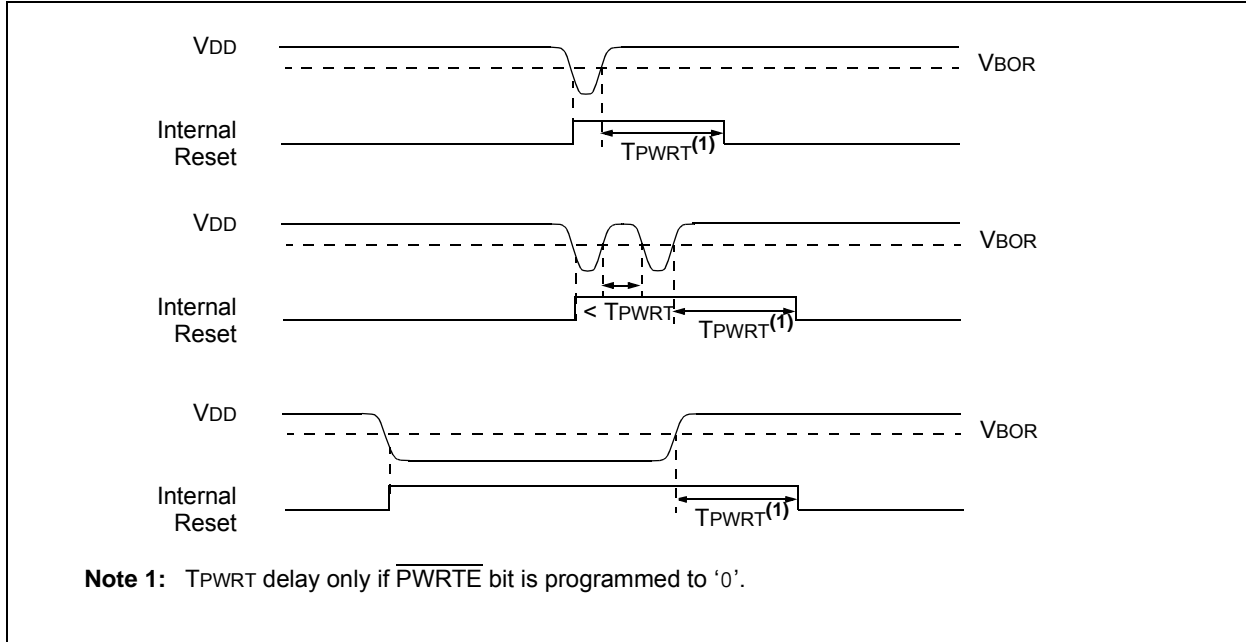

6.3 Register Definitions: BOR Control

REGISTER 6-1: BORCON: BROWN-OUT RESET CONTROL REGISTER

R/W-1/u	R/W-0/u	U-0	U-0	U-0	U-0	U-0	R-q/u
SBOREN	BORFS	—	—	—	—	—	BORRDY
bit 7							bit 0

Legend:

R = Readable bit	W = Writable bit	U = Unimplemented bit, read as '0'
u = Bit is unchanged	x = Bit is unknown	-n/n = Value at POR and BOR/Value at all other Resets
'1' = Bit is set	'0' = Bit is cleared	q = Value depends on condition

- bit 7 **SBOREN:** Software Brown-Out Reset Enable bit
If BOREN <1:0> in Configuration Words = 01:
 1 = BOR Enabled
 0 = BOR Disabled
If BOREN <1:0> in Configuration Words ≠ 01:
 SBOREN is read/write, but has no effect on the BOR
- bit 6 **BORFS:** Brown-Out Reset Fast Start bit⁽¹⁾
If BOREN <1:0> = 10 (Disabled in Sleep) or BOREN <1:0> = 01 (Under software control):
 1 = Band gap is forced on always (covers sleep/wake-up/operating cases)
 0 = Band gap operates normally, and may turn off
If BOREN <1:0> = 11 (Always on) or BOREN <1:0> = 00 (Always off)
 BORFS is Read/Write, but has no effect.
- bit 5-1 **Unimplemented:** Read as '0'
- bit 0 **BORRDY:** Brown-Out Reset Circuit Ready Status bit
 1 = The Brown-out Reset circuit is active
 0 = The Brown-out Reset circuit is inactive

Note 1: BOREN<1:0> bits are located in Configuration Words.

6.4 Low-Power Brown-out Reset (LPBOR)

The Low-Power Brown-Out Reset (LPBOR) operates like the BOR to detect low voltage conditions on the VDD pin. When too low of a voltage is detected, the device is held in Reset. When this occurs, a register bit (BOR) is changed to indicate that a BOR Reset has occurred. The BOR bit in PCON is used for both BOR and the LPBOR. Refer to [Register 6-2](#).

The LPBOR voltage threshold (VLPBOR) has a wider tolerance than the BOR (VBOR), but requires much less current (LPBOR current) to operate. The LPBOR is intended for use when the BOR is configured as disabled (BOREN = 00) or disabled in Sleep mode (BOREN = 10).

Refer to [Figure 6-1](#) to see how the LPBOR interacts with other modules.

6.4.1 ENABLING LPBOR

The LPBOR is controlled by the LPBOR bit of Configuration Words. When the device is erased, the LPBOR module defaults to disabled.

6.5 MCLR

The MCLR is an optional external input that can reset the device. The MCLR function is controlled by the MCLRE bit of Configuration Words and the LVP bit of Configuration Words ([Table 6-2](#)).

TABLE 6-2: MCLR CONFIGURATION

MCLRE	LVP	MCLR
0	0	Disabled
1	0	Enabled
x	1	Enabled

6.5.1 MCLR ENABLED

When MCLR is enabled and the pin is held low, the device is held in Reset. The MCLR pin is connected to VDD through an internal weak pull-up.

The device has a noise filter in the MCLR Reset path. The filter will detect and ignore small pulses.

Note: A Reset does not drive the MCLR pin low.

6.5.2 MCLR DISABLED

When MCLR is disabled, the pin functions as a general purpose input and the internal weak pull-up is under software control. See [Section 11.3 “PORTA Registers”](#) for more information.

6.6 Watchdog Timer (WDT) Reset

The Watchdog Timer generates a Reset if the firmware does not issue a CLRWDT instruction within the time-out period. The TO and PD bits in the STATUS register are changed to indicate the WDT Reset. See [Section 9.0 “Watchdog Timer \(WDT\)”](#) for more information.

6.7 RESET Instruction

A RESET instruction will cause a device Reset. The RI bit in the PCON register will be set to ‘0’. See [Table 6-4](#) for default conditions after a RESET instruction has occurred.

6.8 Stack Overflow/Underflow Reset

The device can reset when the Stack Overflows or Underflows. The STKOVF or STKUNF bits of the PCON register indicate the Reset condition. These Resets are enabled by setting the STVREN bit in Configuration Words. See [Section 3.4.2 “Overflow/Underflow Reset”](#) for more information.

6.9 Programming Mode Exit

Upon exit of Programming mode, the device will behave as if a POR had just occurred.

6.10 Power-up Timer

The Power-up Timer optionally delays device execution after a BOR or POR event. This timer is typically used to allow VDD to stabilize before allowing the device to start running.

The Power-up Timer is controlled by the PWRTEN bit of Configuration Words.

6.11 Start-up Sequence

Upon the release of a POR or BOR, the following must occur before the device will begin executing:

1. Power-up Timer runs to completion (if enabled).
2. MCLR must be released (if enabled).

The total time-out will vary based on oscillator configuration and Power-up Timer configuration. See [Section 5.0 “Oscillator Module”](#) for more information.

The Power-up Timer runs independently of MCLR Reset. If MCLR is kept low long enough, the Power-up Timer will expire. Upon bringing MCLR high, the device will begin execution after 10 FOSC cycles (see [Figure 6-3](#)). This is useful for testing purposes or to synchronize more than one device operating in parallel.

PIC16LF1554/1559

FIGURE 6-3: RESET START-UP SEQUENCE

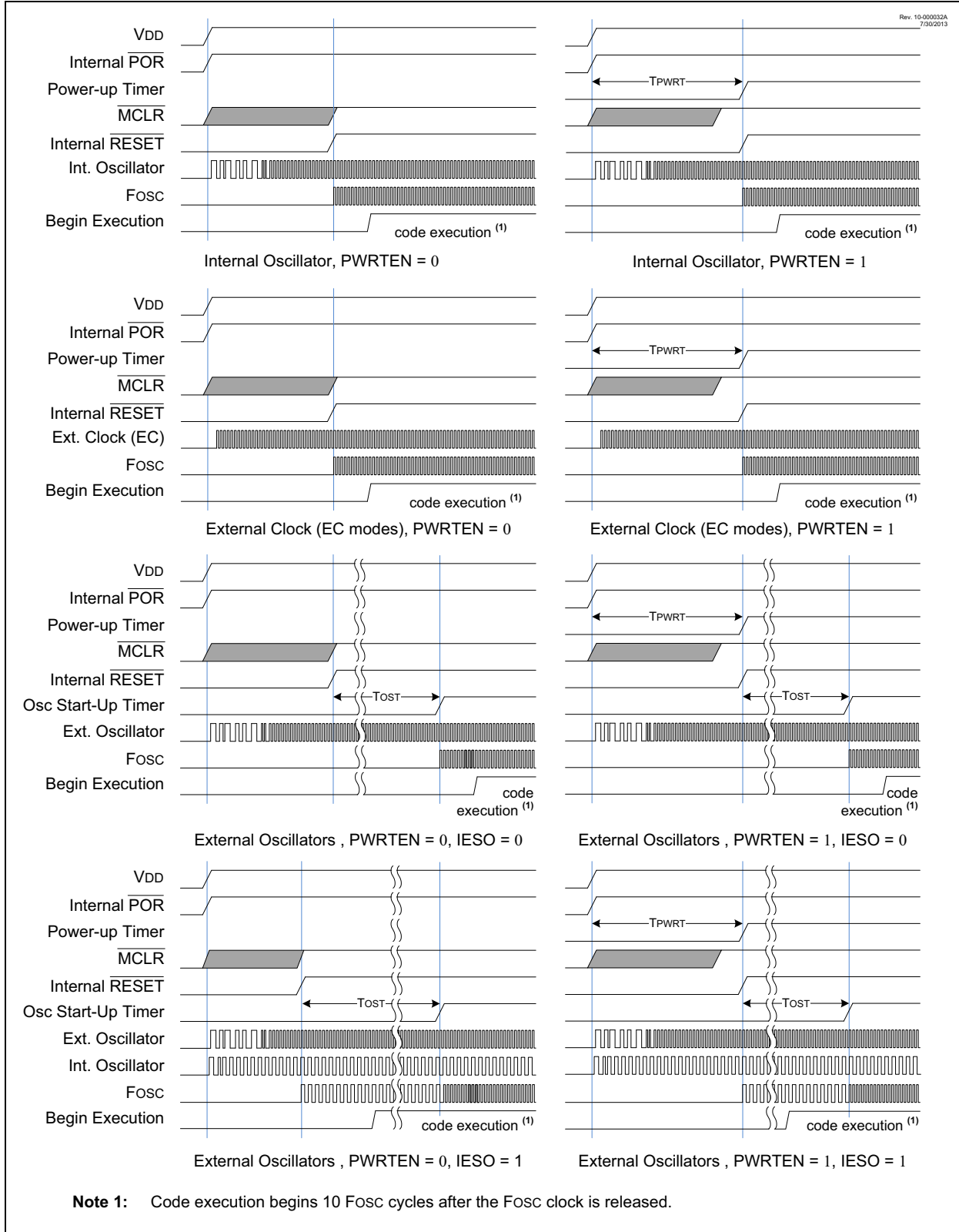

6.12 Determining the Cause of a Reset

Upon any Reset, multiple bits in the STATUS and PCON registers are updated to indicate the cause of the Reset. Table 6-3 and Table 6-4 show the Reset conditions of these registers.

TABLE 6-3: RESET STATUS BITS AND THEIR SIGNIFICANCE

STKOVF	STKUNF	RWD \overline{T}	RMCLR	RI	POR	BOR	TO	PD	Condition
0	0	1	1	1	0	x	1	1	Power-on Reset
0	0	1	1	1	0	x	0	x	Illegal, \overline{TO} is set on \overline{POR}
0	0	1	1	1	0	x	x	0	Illegal, \overline{PD} is set on \overline{POR}
0	0	u	1	1	u	0	1	1	Brown-out Reset
u	u	0	u	u	u	u	0	u	WDT Reset
u	u	u	u	u	u	u	0	0	WDT Wake-up from Sleep
u	u	u	u	u	u	u	1	0	Interrupt Wake-up from Sleep
u	u	u	0	u	u	u	u	u	\overline{MCLR} Reset during normal operation
u	u	u	0	u	u	u	1	0	\overline{MCLR} Reset during Sleep
u	u	u	u	0	u	u	u	u	RESET Instruction Executed
1	u	u	u	u	u	u	u	u	Stack Overflow Reset (STVREN = 1)
u	1	u	u	u	u	u	u	u	Stack Underflow Reset (STVREN = 1)

TABLE 6-4: RESET CONDITION FOR SPECIAL REGISTERS

Condition	Program Counter	STATUS Register	PCON Register
Power-on Reset	0000h	---1 1000	00-- 110x
\overline{MCLR} Reset during normal operation	0000h	---u uuuu	uu-- 0uuu
\overline{MCLR} Reset during Sleep	0000h	---1 0uuu	uu-- 0uuu
WDT Reset	0000h	---0 uuuu	uu-- uuuu
WDT Wake-up from Sleep	PC + 1	---0 0uuu	uu-- uuuu
Brown-out Reset	0000h	---1 1uuu	00-- 11u0
Interrupt Wake-up from Sleep	PC + 1 ⁽¹⁾	---1 0uuu	uu-- uuuu
RESET Instruction Executed	0000h	---u uuuu	uu-- u0uu
Stack Overflow Reset (STVREN = 1)	0000h	---u uuuu	1u-- uuuu
Stack Underflow Reset (STVREN = 1)	0000h	---u uuuu	u1-- uuuu

Legend: u = unchanged, x = unknown, - = unimplemented bit, reads as '0'.

Note 1: When the wake-up is due to an interrupt and the Global Interrupt Enable bit (GIE) is set, the return address is pushed on the stack and PC is loaded with the interrupt vector (0004h) after execution of PC + 1.

PIC16LF1554/1559

6.13 Power Control (PCON) Register

The Power Control (PCON) register contains flag bits to differentiate between a:

- Power-On Reset ($\overline{\text{POR}}$)
- Brown-Out Reset ($\overline{\text{BOR}}$)
- Reset Instruction Reset ($\overline{\text{RI}}$)
- MCLR Reset ($\overline{\text{RMCLR}}$)
- Watchdog Timer Reset ($\overline{\text{RWDT}}$)
- Stack Underflow Reset (STKUNF)
- Stack Overflow Reset (STKOVF)

The PCON register bits are shown in [Register 6-2](#).

6.14 Register Definitions: Power Control

REGISTER 6-2: PCON: POWER CONTROL REGISTER

R/W/HS-0/q	R/W/HS-0/q	U-0	R/W/HC-1/q	R/W/HC-1/q	R/W/HC-1/q	R/W/HC-q/u	R/W/HC-q/u
STKOVF	STKUNF	—	$\overline{\text{RWDT}}$	$\overline{\text{RMCLR}}$	$\overline{\text{RI}}$	$\overline{\text{POR}}$	$\overline{\text{BOR}}$
bit 7							bit 0

Legend:

HC = Bit is cleared by hardware	HS = Bit is set by hardware
R = Readable bit	W = Writable bit
u = Bit is unchanged	U = Unimplemented bit, read as '0'
'1' = Bit is set	x = Bit is unknown
	-n/n = Value at POR and BOR/Value at all other Resets
	q = Value depends on condition

bit 7	<p>STKOVF: Stack Overflow Flag bit</p> <p>1 = A Stack Overflow occurred</p> <p>0 = A Stack Overflow has not occurred or cleared by firmware</p>
bit 6	<p>STKUNF: Stack Underflow Flag bit</p> <p>1 = A Stack Underflow occurred</p> <p>0 = A Stack Underflow has not occurred or cleared by firmware</p>
bit 5	Unimplemented: Read as '0'
bit 4	<p>$\overline{\text{RWDT}}$: Watchdog Timer Reset Flag bit</p> <p>1 = A Watchdog Timer Reset has not occurred or set by firmware</p> <p>0 = A Watchdog Timer Reset has occurred (cleared by hardware)</p>
bit 3	<p>$\overline{\text{RMCLR}}$: MCLR Reset Flag bit</p> <p>1 = A MCLR Reset has not occurred or set by firmware</p> <p>0 = A MCLR Reset has occurred (cleared by hardware)</p>
bit 2	<p>$\overline{\text{RI}}$: RESET Instruction Flag bit</p> <p>1 = A RESET instruction has not been executed or set by firmware</p> <p>0 = A RESET instruction has been executed (cleared by hardware)</p>
bit 1	<p>$\overline{\text{POR}}$: Power-On Reset Status bit</p> <p>1 = No Power-on Reset occurred</p> <p>0 = A Power-on Reset occurred (must be set in software after a Power-on Reset occurs)</p>
bit 0	<p>$\overline{\text{BOR}}$: Brown-Out Reset Status bit</p> <p>1 = No Brown-out Reset occurred</p> <p>0 = A Brown-out Reset occurred (must be set in software after a Power-on Reset or Brown-out Reset occurs)</p>

TABLE 6-5: SUMMARY OF REGISTERS ASSOCIATED WITH RESETS⁽¹⁾

Name	Bit 7	Bit 6	Bit 5	Bit 4	Bit 3	Bit 2	Bit 1	Bit 0	Register on Page
BORCON	SBOREN	BORFS	—	—	—	—	—	BORRDY	66
PCON	STKOVF	STKUNF	—	$\overline{\text{RWDT}}$	$\overline{\text{RMCLR}}$	$\overline{\text{RI}}$	$\overline{\text{POR}}$	$\overline{\text{BOR}}$	70
STATUS	—	—	—	$\overline{\text{TO}}$	$\overline{\text{PD}}$	Z	DC	C	22
WDTCON	—	—	WDTPS<4:0>					SWDTEN	86

Legend: — = unimplemented bit, reads as '0'. Shaded cells are not used by Resets.

Note 1: Other (non Power-up) Resets include $\overline{\text{MCLR}}$ Reset and Watchdog Timer Reset during normal operation.

TABLE 6-6: SUMMARY OF CONFIGURATION WORD WITH RESETS

Name	Bits	Bit -/7	Bit -/6	Bit 13/5	Bit 12/4	Bit 11/3	Bit 10/2	Bit 9/1	Bit 8/0	Register on Page
CONFIG1	13:8	—	—	—	—	$\overline{\text{CLKOUTEN}}$	BOREN<1:0>		—	53
	7:0	$\overline{\text{CP}}$	MCLRE	$\overline{\text{PWRTE}}$	WDTE<1:0>		—	FOSC<1:0>		
CONFIG2	13:8	—	—	LVP	$\overline{\text{DEBUG}}$	$\overline{\text{LPBOR}}$	BORV	STVREN	—	54
	7:0	—	—	—	—	—	—	WRT<1:0>		

Legend: — = unimplemented location, read as '0'. Shaded cells are not used by Resets.

PIC16LF1554/1559

7.0 INTERRUPTS

The interrupt feature allows certain events to preempt normal program flow. Firmware is used to determine the source of the interrupt and act accordingly. Some interrupts can be configured to wake the MCU from Sleep mode.

This chapter contains the following information for interrupts:

- Operation
- Interrupt latency
- Interrupts during Sleep
- INT pin
- Automatic context saving

Many peripherals produce interrupts. Refer to the corresponding chapters for details.

A block diagram of the interrupt logic is shown in [Figure 7-1](#).

FIGURE 7-1: INTERRUPT LOGIC

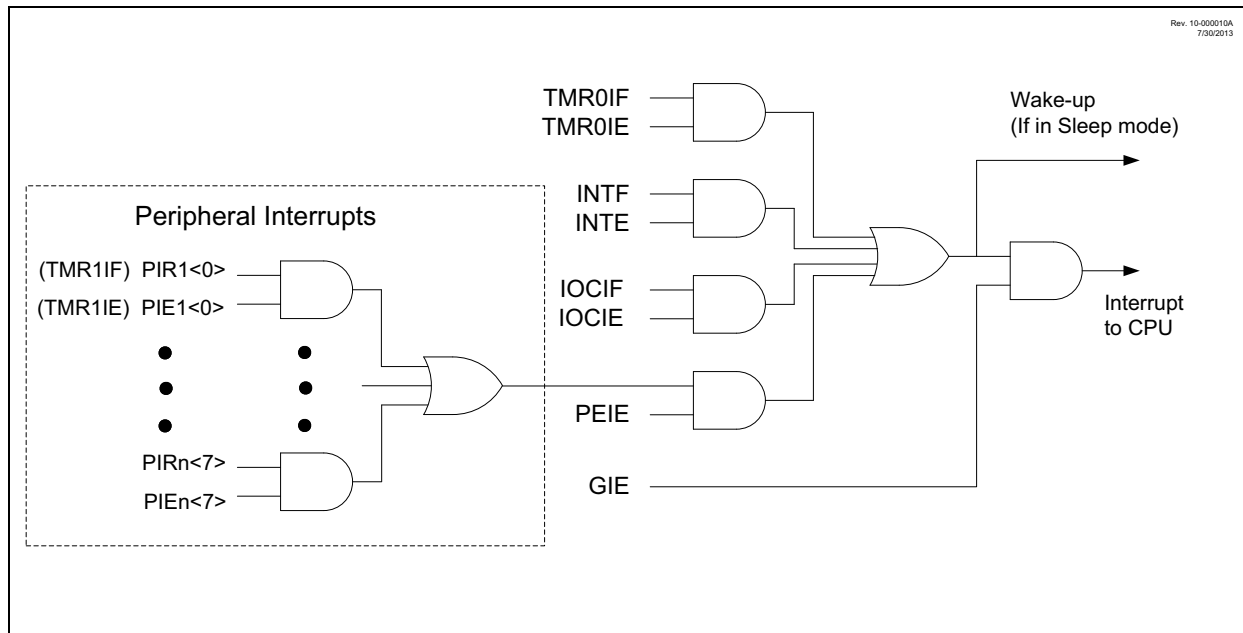

7.1 Operation

Interrupts are disabled upon any device Reset. They are enabled by setting the following bits:

- GIE bit of the INTCON register
- Interrupt enable bit(s) for the specific interrupt event(s)
- PEIE bit of the INTCON register (if the interrupt enable bit of the interrupt event is contained in the PIE1, PIE2 and PIE3 registers)

The INTCON, PIR1, PIR2 and PIR3 registers record individual interrupts via interrupt flag bits. Interrupt flag bits will be set, regardless of the status of the GIE, PEIE and individual interrupt enable bits.

The following events happen when an interrupt event occurs while the GIE bit is set:

- Current prefetched instruction is flushed
- GIE bit is cleared
- Current Program Counter (PC) is pushed onto the stack
- Critical registers are automatically saved to the shadow registers (See “[Section 7.5 “Automatic Context Saving”](#).”)
- PC is loaded with the interrupt vector 0004h

The firmware within the Interrupt Service Routine (ISR) should determine the source of the interrupt by polling the interrupt flag bits. The interrupt flag bits must be cleared before exiting the ISR to avoid repeated interrupts. Because the GIE bit is cleared, any interrupt that occurs while executing the ISR will be recorded through its interrupt flag, but will not cause the processor to redirect to the interrupt vector.

The `RETFIE` instruction exits the ISR by popping the previous address from the stack, restoring the saved context from the shadow registers and setting the GIE bit.

For additional information on a specific interrupt's operation, refer to its peripheral chapter.

Note 1: Individual interrupt flag bits are set, regardless of the state of any other enable bits.

2: All interrupts will be ignored while the GIE bit is cleared. Any interrupt occurring while the GIE bit is clear will be serviced when the GIE bit is set again.

PIC16LF1554/1559

7.2 Interrupt Latency

Interrupt latency is defined as the time from when the interrupt event occurs to the time code execution at the interrupt vector begins. The latency for synchronous interrupts is three or four instruction cycles. For asynchronous interrupts, the latency is three to five instruction cycles, depending on when the interrupt occurs. See [Figure 7-2](#) and [Figure 7-3](#) for more details.

FIGURE 7-2: INTERRUPT LATENCY

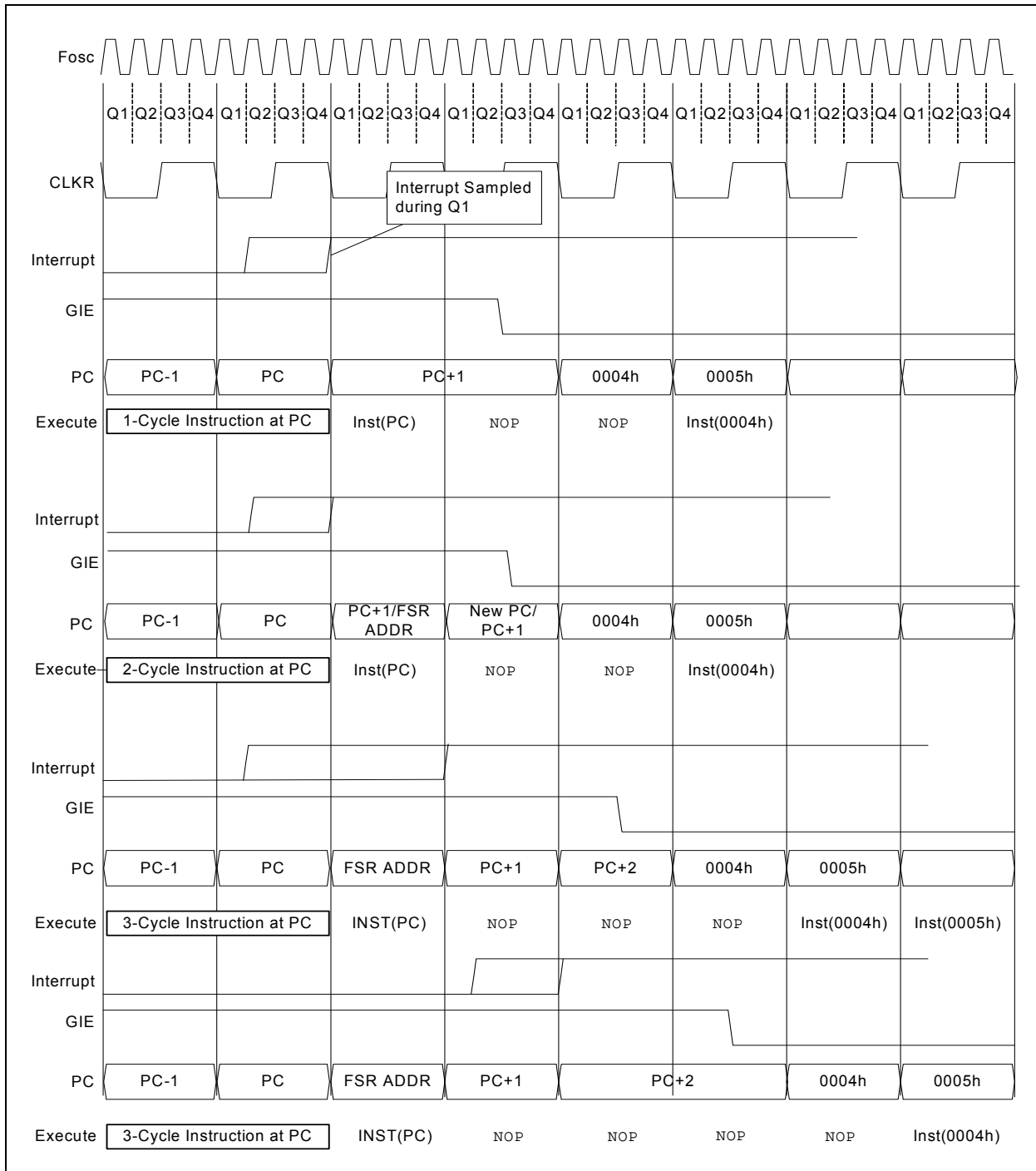
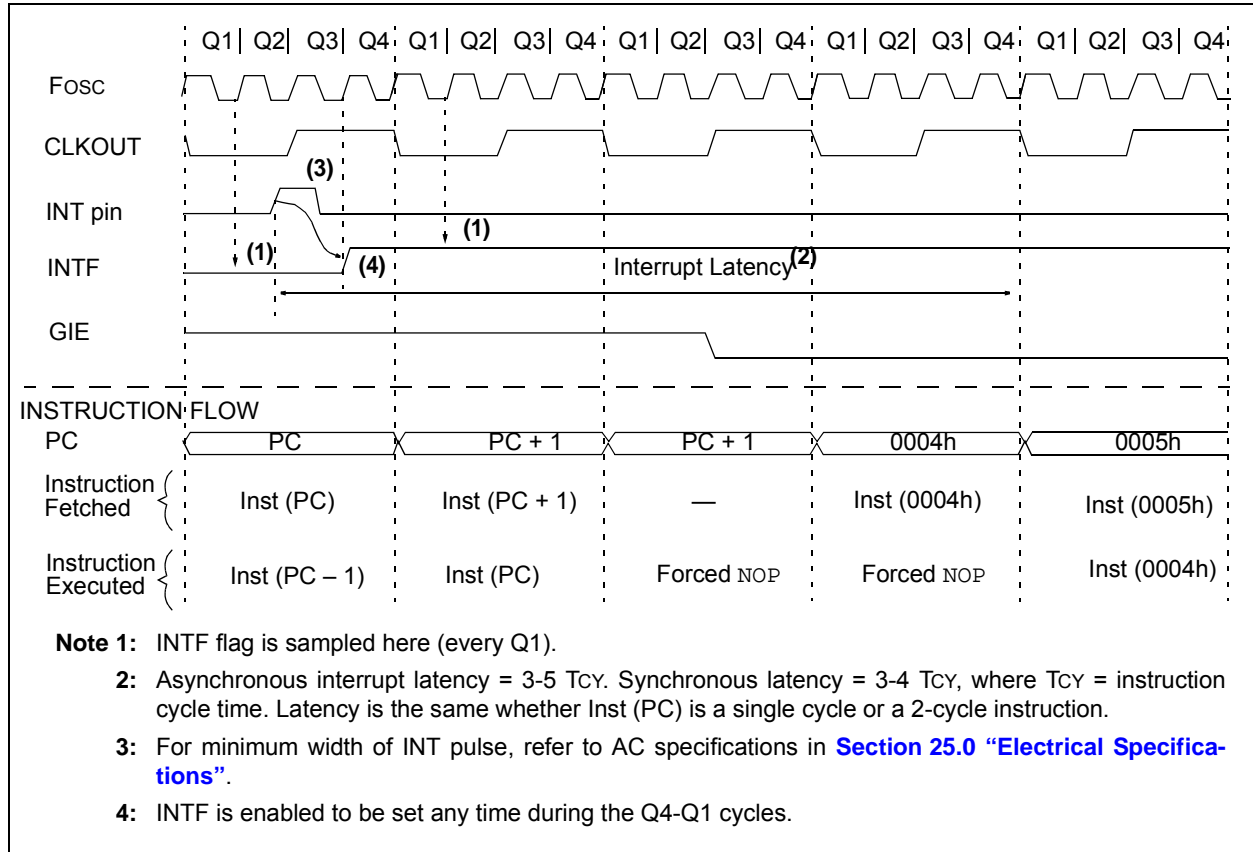

FIGURE 7-3: INT PIN INTERRUPT TIMING



7.3 Interrupts During Sleep

Some interrupts can be used to wake from Sleep. To wake from Sleep, the peripheral must be able to operate without the system clock. The interrupt source must have the appropriate interrupt enable bit(s) set prior to entering Sleep.

On waking from Sleep, if the GIE bit is also set, the processor will branch to the interrupt vector. Otherwise, the processor will continue executing instructions after the `SLEEP` instruction. The instruction directly after the `SLEEP` instruction will always be executed before branching to the ISR. Refer to [Section 8.0 “Power-Down Mode \(Sleep\)”](#) for more details.

7.4 INT Pin

The INT pin can be used to generate an asynchronous edge-triggered interrupt. This interrupt is enabled by setting the INTE bit of the INTCON register. The INTEDG bit of the OPTION_REG register determines on which edge the interrupt will occur. When the INTEDG bit is set, the rising edge will cause the interrupt. When the INTEDG bit is clear, the falling edge will cause the interrupt. The INTF bit of the INTCON register will be set when a valid edge appears on the INT pin. If the GIE and INTE bits are also set, the processor will redirect program execution to the interrupt vector.

7.5 Automatic Context Saving

Upon entering an interrupt, the return PC address is saved on the stack. Additionally, the following registers are automatically saved in the shadow registers:

- W register
- STATUS register (except for \overline{TO} and \overline{PD})
- BSR register
- FSR registers
- PCLATH register

Upon exiting the Interrupt Service Routine, these registers are automatically restored. Any modifications to these registers during the ISR will be lost. If modifications to any of these registers are desired, the corresponding shadow register should be modified and the value will be restored when exiting the ISR. The shadow registers are available in Bank 31 and are readable and writable. Depending on the user's application, other registers may also need to be saved.

7.6 Register Definitions: Interrupt Control

REGISTER 7-1: INTCON: INTERRUPT CONTROL REGISTER

R/W-0/0	R/W-0/0	R/W-0/0	R/W-0/0	R/W-0/0	R/W-0/0	R/W-0/0	R-0/0
GIE ⁽¹⁾	PEIE ⁽²⁾	TMR0IE	INTE	IOCIE	TMR0IF	INTF	IOCIF ⁽³⁾
bit 7							bit 0

Legend:

R = Readable bit	W = Writable bit	U = Unimplemented bit, read as '0'
u = Bit is unchanged	x = Bit is unknown	-n/n = Value at POR and BOR/Value at all other Resets
'1' = Bit is set	'0' = Bit is cleared	

- bit 7 **GIE:** Global Interrupt Enable bit⁽¹⁾
1 = Enables all active interrupts
0 = Disables all interrupts
- bit 6 **PEIE:** Peripheral Interrupt Enable bit⁽²⁾
1 = Enables all active peripheral interrupts
0 = Disables all peripheral interrupts
- bit 5 **TMR0IE:** Timer0 Overflow Interrupt Enable bit
1 = Enables the Timer0 interrupt
0 = Disables the Timer0 interrupt
- bit 4 **INTE:** INT External Interrupt Enable bit
1 = Enables the INT external interrupt
0 = Disables the INT external interrupt
- bit 3 **IOCIE:** Interrupt-on-Change Enable bit
1 = Enables the interrupt-on-change
0 = Disables the interrupt-on-change
- bit 2 **TMR0IF:** Timer0 Overflow Interrupt Flag bit
1 = TMR0 register has overflowed
0 = TMR0 register did not overflow
- bit 1 **INTF:** INT External Interrupt Flag bit
1 = The INT external interrupt occurred
0 = The INT external interrupt did not occur
- bit 0 **IOCIF:** Interrupt-on-Change Interrupt Flag bit⁽³⁾
1 = When at least one of the interrupt-on-change pins changed state
0 = None of the interrupt-on-change pins have changed state

Note 1: Interrupt flag bits are set when an interrupt condition occurs, regardless of the state of its corresponding enable bit or the Global Interrupt Enable bit, GIE of the INTCON register. User software should ensure the appropriate interrupt flag bits are clear prior to enabling an interrupt.

2: Bit PEIE of the INTCON register must be set to enable any peripheral interrupt.

3: The IOCIF flag bit is read-only and cleared when all the interrupt-on-change flags in the IOCxF registers have been cleared by software.

PIC16LF1554/1559

REGISTER 7-2: PIE1: PERIPHERAL INTERRUPT ENABLE REGISTER 1

R/W-0/0	R/W-0/0	R/W-0/0	R/W-0/0	R/W-0/0	U-0	R/W-0/0	R/W-0/0
TMR1GIE	AD1IE	RCIE	TXIE	SSP1IE	—	TMR2IE	TMR1IE
bit 7							bit 0

Legend:

R = Readable bit	W = Writable bit	U = Unimplemented bit, read as '0'
u = Bit is unchanged	x = Bit is unknown	-n/n = Value at POR and BOR/Value at all other Resets
'1' = Bit is set	'0' = Bit is cleared	

- bit 7 **TMR1GIE:** Timer1 Gate Interrupt Enable bit
1 = Enables the Timer1 gate acquisition interrupt
0 = Disables the Timer1 gate acquisition interrupt
- bit 6 **AD1IE:** Analog-to-Digital Converter (ADC1) Interrupt Enable bit
1 = Enables the ADC interrupt
0 = Disables the ADC interrupt
- bit 5 **RCIE:** USART Receive Interrupt Enable bit
1 = Enables the USART receive interrupt
0 = Disables the USART receive interrupt
- bit 4 **TXIE:** USART Transmit Interrupt Enable bit
1 = Enables the USART transmit interrupt
0 = Disables the USART transmit interrupt
- bit 3 **SSP1IE:** Synchronous Serial Port (MSSP) Interrupt Enable bit
1 = Enables the MSSP interrupt
0 = Disables the MSSP interrupt
- bit 2 **Unimplemented:** Read as '0'
- bit 1 **TMR2IE:** TMR2 to PR2 Match Interrupt Enable bit
1 = Enables the Timer2 to PR2 match interrupt
0 = Disables the Timer2 to PR2 match interrupt
- bit 0 **TMR1IE:** Timer1 Overflow Interrupt Enable bit
1 = Enables the Timer1 overflow interrupt
0 = Disables the Timer1 overflow interrupt

Note: Bit PEIE of the INTCON register must be set to enable any peripheral interrupt.

REGISTER 7-3: PIE2: PERIPHERAL INTERRUPT ENABLE REGISTER 2

U-0	R/W-0/0	U-0	U-0	R/W-0/0	U-0	U-0	U-0
—	AD2IE	—	—	BCLIE	—	—	—
bit 7							bit 0

Legend:

R = Readable bit

W = Writable bit

U = Unimplemented bit, read as '0'

u = Bit is unchanged

x = Bit is unknown

-n/n = Value at POR and BOR/Value at all other Resets

'1' = Bit is set

'0' = Bit is cleared

- bit 7 **Unimplemented:** Read as '0'
- bit 6 **AD2IE:** Analog-to-Digital Converter (ADC) 2 Interrupt Enable bit
1 = Enables the ADC interrupt
0 = Disables the ADC interrupt
- bit 5-4 **Unimplemented:** Read as '0'
- bit 3 **BCLIE:** MSSP Bus Collision Interrupt Enable bit
1 = Enables the MSSP Bus Collision Interrupt
0 = Disables the MSSP Bus Collision Interrupt
- bit 2-0 **Unimplemented:** Read as '0'

Note: Bit PEIE of the INTCON register must be set to enable any peripheral interrupt.

PIC16LF1554/1559

REGISTER 7-4: PIR1: PERIPHERAL INTERRUPT REQUEST REGISTER 1

R/W-0/0	R/W-0/0	R/W-0/0	R/W-0/0	R/W-0/0	U-0	R/W-0/0	R/W-0/0
TMR1GIF	AD1IF	RCIF	TXIF	SSP1IF	—	TMR2IF	TMR1IF
bit 7							bit 0

Legend:

R = Readable bit	W = Writable bit	U = Unimplemented bit, read as '0'
u = Bit is unchanged	x = Bit is unknown	-n/n = Value at POR and BOR/Value at all other Resets
'1' = Bit is set	'0' = Bit is cleared	

- bit 7 **TMR1GIF:** Timer1 Gate Interrupt Flag bit
1 = Interrupt is pending
0 = Interrupt is not pending
- bit 6 **AD1IF:** ADC 1 Interrupt Flag bit
1 = Interrupt is pending
0 = Interrupt is not pending
- bit 5 **RCIF:** USART Receive Interrupt Flag bit
1 = Interrupt is pending
0 = Interrupt is not pending
- bit 4 **TXIF:** USART Transmit Interrupt Flag bit
1 = Interrupt is pending
0 = Interrupt is not pending
- bit 3 **SSP1IF:** Synchronous Serial Port (MSSP) Interrupt Flag bit
1 = Interrupt is pending
0 = Interrupt is not pending
- bit 2 **Unimplemented:** Read as '0'
- bit 1 **TMR2IF:** Timer2 to PR2 Interrupt Flag bit
1 = Interrupt is pending
0 = Interrupt is not pending
- bit 0 **TMR1IF:** Timer1 Overflow Interrupt Flag bit
1 = Interrupt is pending
0 = Interrupt is not pending

Note: Interrupt flag bits are set when an interrupt condition occurs, regardless of the state of its corresponding enable bit or the Global Interrupt Enable bit, GIE of the INTCON register. User software should ensure the appropriate interrupt flag bits are clear prior to enabling an interrupt.

REGISTER 7-5: PIR2: PERIPHERAL INTERRUPT REQUEST REGISTER 2

U-0	R/W-0/0	U-0	U-0	R/W-0/0	U-0	U-0	U-0
—	AD2IF	—	—	BCLIF	—	—	—
bit 7							bit 0

Legend:

R = Readable bit W = Writable bit U = Unimplemented bit, read as '0'
u = Bit is unchanged x = Bit is unknown -n/n = Value at POR and BOR/Value at all other Resets
'1' = Bit is set '0' = Bit is cleared

bit 7 **Unimplemented:** Read as '0'
bit 6 **AD2IF:** ADC 2 Interrupt Flag bit
 1 = Interrupt is pending
 0 = Interrupt is not pending
bit 5-4 **Unimplemented:** Read as '0'
bit 3 **BCLIF:** MSSP Bus Collision Interrupt Flag bit
 1 = Interrupt is pending
 0 = Interrupt is not pending
bit 2-0 **Unimplemented:** Read as '0'

Note: Interrupt flag bits are set when an interrupt condition occurs, regardless of the state of its corresponding enable bit or the Global Interrupt Enable bit, GIE of the INTCON register. User software should ensure the appropriate interrupt flag bits are clear prior to enabling an interrupt.

TABLE 7-1: SUMMARY OF REGISTERS ASSOCIATED WITH INTERRUPTS

Name	Bit 7	Bit 6	Bit 5	Bit 4	Bit 3	Bit 2	Bit 1	Bit 0	Register on Page
INTCON	GIE	PEIE	TMR0IE	INTE	IOCIE	TMR0IF	INTF	IOCIF	77
OPTION_REG	$\overline{\text{WPUEN}}$	INTEDG	TMR0CS	TMR0SE	PSA	PS<2:0>			166
PIE1	TMR1GIE	AD1IE	RCIE	TXIE	SSP1IE	—	TMR2IE	TMR1IE	78
PIE2	—	AD2IE	—	—	BCLIE	—	—	—	79
PIR1	TMR1GIF	AD1IF	RCIF	TXIF	SSP1IF	—	TMR2IF	TMR1IF	80
PIR2	—	AD2IF	—	—	BCLIF	—	—	—	81

Legend: — = unimplemented location, read as '0'. Shaded cells are not used by interrupts.

PIC16LF1554/1559

8.0 POWER-DOWN MODE (SLEEP)

The Power-Down mode is entered by executing a `SLEEP` instruction.

Upon entering Sleep mode, the following conditions exist:

1. WDT will be cleared but keeps running, if enabled for operation during Sleep.
2. \overline{PD} bit of the STATUS register is cleared.
3. \overline{TO} bit of the STATUS register is set.
4. CPU clock is disabled.
5. 31 kHz LFINTOSC is unaffected and peripherals that operate from it may continue operation in Sleep.
6. Timer1 and peripherals that operate from Timer1 continue operation in Sleep when the Timer1 clock source selected is:
 - LFINTOSC
 - T1CKI
 - Timer1 oscillator
7. ADC is unaffected, if the dedicated FRC oscillator is selected.
8. I/O ports maintain the status they had before `SLEEP` was executed (driving high, low or high-impedance).
9. Resets other than WDT are not affected by Sleep mode.

Refer to individual chapters for more details on peripheral operation during Sleep.

To minimize current consumption, the following conditions should be considered:

- I/O pins should not be floating
- External circuitry sinking current from I/O pins
- Internal circuitry sourcing current from I/O pins
- Current draw from pins with internal weak pull-ups
- Modules using 31 kHz LFINTOSC

I/O pins that are high-impedance inputs should be pulled to V_{DD} or V_{SS} externally to avoid switching currents caused by floating inputs.

Examples of internal circuitry that might be sourcing current include the FVR module. See [Section 13.0 “Fixed Voltage Reference \(FVR\)”](#) for more information on this module.

8.1 Wake-up from Sleep

The device can wake-up from Sleep through one of the following events:

1. External Reset input on \overline{MCLR} pin, if enabled
2. BOR Reset, if enabled
3. POR Reset
4. Watchdog Timer, if enabled
5. Any external interrupt
6. Interrupts by peripherals capable of running during Sleep (see individual peripheral for more information)

The first three events will cause a device Reset. The last three events are considered a continuation of program execution. To determine whether a device Reset or wake-up event occurred, refer to [Section 6.12 “Determining the Cause of a Reset”](#).

When the `SLEEP` instruction is being executed, the next instruction ($PC + 1$) is prefetched. For the device to wake-up through an interrupt event, the corresponding interrupt enable bit must be enabled. Wake-up will occur regardless of the state of the GIE bit. If the GIE bit is disabled, the device continues execution at the instruction after the `SLEEP` instruction. If the GIE bit is enabled, the device executes the instruction after the `SLEEP` instruction, the device will then call the Interrupt Service Routine. In cases where the execution of the instruction following `SLEEP` is not desirable, the user should have a `NOP` after the `SLEEP` instruction.

The WDT is cleared when the device wakes up from Sleep, regardless of the source of wake-up.

8.1.1 WAKE-UP USING INTERRUPTS

When global interrupts are disabled (GIE cleared) and any interrupt source has both its interrupt enable bit and interrupt flag bit set, one of the following will occur:

- If the interrupt occurs **before** the execution of a `SLEEP` instruction
 - `SLEEP` instruction will execute as a NOP.
 - WDT and WDT prescaler will not be cleared
 - \overline{TO} bit of the STATUS register will not be set
 - \overline{PD} bit of the STATUS register will not be cleared.
- If the interrupt occurs **during or after** the execution of a `SLEEP` instruction
 - `SLEEP` instruction will be completely executed
 - Device will immediately wake-up from Sleep
 - WDT and WDT prescaler will be cleared
 - \overline{TO} bit of the STATUS register will be set
 - \overline{PD} bit of the STATUS register will be cleared

Even if the flag bits were checked before executing a `SLEEP` instruction, it may be possible for flag bits to become set before the `SLEEP` instruction completes. To determine whether a `SLEEP` instruction executed, test the \overline{PD} bit. If the \overline{PD} bit is set, the `SLEEP` instruction was executed as a NOP.

TABLE 8-1: SUMMARY OF REGISTERS ASSOCIATED WITH POWER-DOWN MODE

Name	Bit 7	Bit 6	Bit 5	Bit 4	Bit 3	Bit 2	Bit 1	Bit 0	Register on Page
INTCON	GIE	PEIE	TMR0IE	INTE	IOCFIE	TMR0IF	INTF	IOCFIF	77
IOCAF	—	—	IOCAF5	IOCAF4	IOCAF3	IOCAF2	IOCAF1	IOCAF0	120
IOCAN	—	—	IOCAN5	IOCAN4	IOCAN3	IOCAN2	IOCAN1	IOCAN0	120
IOCAP	—	—	IOCAP5	IOCAP4	IOCAP3	IOCAP2	IOCAP1	IOCAP0	120
IOCBF ⁽¹⁾	IOCBF7	IOCBF6	IOCBF5	IOCBF4	—	—	—	—	121
IOCBN ⁽¹⁾	IOCBN7	IOCBN6	IOCBN5	IOCBN4	—	—	—	—	121
IOCBP ⁽¹⁾	IOCBP7	IOCBP6	IOCBP5	IOCBP4	—	—	—	—	121
PIE1	TMR1GIE	AD1IE	RCIE	TXIE	SSP1IE	—	TMR2IE	TMR1IE	78
PIE2	—	AD2IE	—	—	BCLIE	—	—	—	79
PIR1	TMR1GIF	AD1IF	RCIF	TXIF	SSP1IF	—	TMR2IF	TMR1IF	80
PIR2	—	AD2IF	—	—	BCLIF	—	—	—	81
STATUS	—	—	—	\overline{TO}	\overline{PD}	Z	DC	C	22
WDTCON	—	—	WDTPS<4:0>					SWDTEN	86

Legend: — = unimplemented, read as '0'. Shaded cells are not used in Power-Down mode.

Note 1: These registers are only available for PIC16LF1559.

PIC16LF1554/1559

9.0 WATCHDOG TIMER (WDT)

The Watchdog Timer is a system timer that generates a Reset if the firmware does not issue a `CLRWDT` instruction within the time-out period. The Watchdog Timer is typically used to recover the system from unexpected events.

The WDT has the following features:

- Independent clock source
- Multiple operating modes
 - WDT is always on
 - WDT is off when in Sleep
 - WDT is controlled by software
 - WDT is always off
- Configurable time-out period is from 1 ms to 256 seconds (nominal)
- Multiple Reset conditions
- Operation during Sleep

FIGURE 9-1: WATCHDOG TIMER BLOCK DIAGRAM

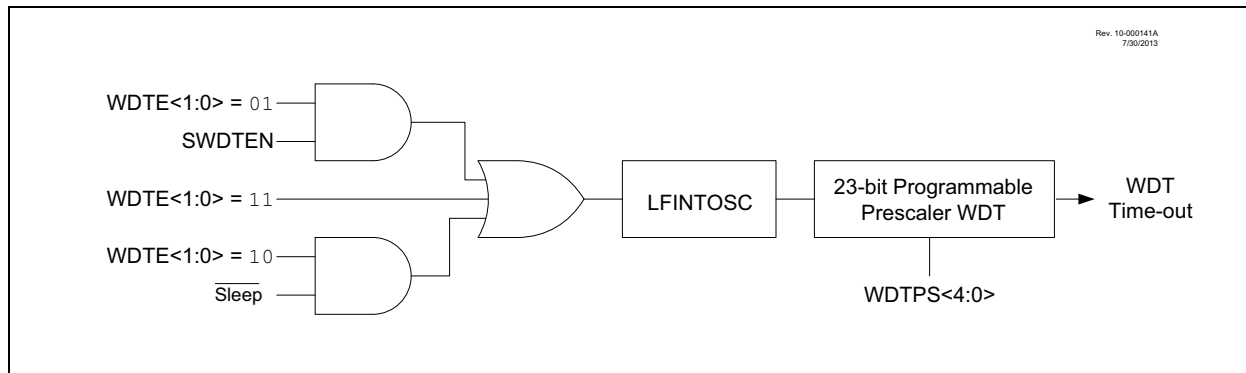

9.1 Independent Clock Source

The WDT derives its time base from the 31 kHz LFINTOSC internal oscillator. Time intervals in this chapter are based on a nominal interval of 1 ms. See [Section 25.0 “Electrical Specifications”](#) for the LFINTOSC tolerances.

9.2 WDT Operating Modes

The Watchdog Timer module has four operating modes controlled by the WDTE<1:0> bits in Configuration Words. See [Table 9-1](#).

9.2.1 WDT IS ALWAYS ON

When the WDTE bits of Configuration Words are set to ‘11’, the WDT is always on.

WDT protection is active during Sleep.

9.2.2 WDT IS OFF IN SLEEP

When the WDTE bits of Configuration Words are set to ‘10’, the WDT is on, except in Sleep.

WDT protection is not active during Sleep.

9.2.3 WDT CONTROLLED BY SOFTWARE

When the WDTE bits of Configuration Words are set to ‘01’, the WDT is controlled by the SWDTEN bit of the WDTCON register.

WDT protection is unchanged by Sleep. See [Table 9-1](#) for more details.

TABLE 9-1: WDT OPERATING MODES

WDTE<1:0>	SWDTEN	Device Mode	WDT Mode
11	x	X	Active
10	x	Awake	Active
		Sleep	Disabled
01	1	X	Active
	0	X	Disabled
00	x	X	Disabled

TABLE 9-2: WDT CLEARING CONDITIONS

Conditions	WDT
WDTE<1:0> = 00	Cleared
WDTE<1:0> = 01 and SWDTEN = 0	
WDTE<1:0> = 10 and enter Sleep	
CLRWDT Command	
Oscillator Fail Detected	
Exit Sleep + System Clock = T1OSC, EXTRC, INTOSC, EXTCLK	Cleared until the end of OST
Exit Sleep + System Clock = XT, HS, LP	
Change INTOSC divider (IRCF bits)	Unaffected

9.3 Time-out Period

The WDTPS bits of the WDTCON register set the time-out period from 1 ms to 256 seconds (nominal). After a Reset, the default time-out period is two seconds.

9.4 Clearing the WDT

The WDT is cleared when any of the following conditions occur:

- Any Reset
- CLRWDT instruction is executed
- Device enters Sleep
- Device wakes up from Sleep
- Oscillator fail
- WDT is disabled
- Oscillator Start-up Timer (OST) is running

See [Table 9-2](#) for more information.

9.5 Operation During Sleep

When the device enters Sleep, the WDT is cleared. If the WDT is enabled during Sleep, the WDT resumes counting. When the device exits Sleep, the WDT is cleared again.

The WDT remains clear until the OST, if enabled, completes. See [Section 5.0 “Oscillator Module”](#) for more information on the OST.

When a WDT time-out occurs while the device is in Sleep, no Reset is generated. Instead, the device wakes up and resumes operation. The TO and PD bits in the STATUS register are changed to indicate the event. The RWDT bit in the PCON register can also be used. See [Section 3.0 “Memory Organization”](#) for more information.

PIC16LF1554/1559

9.6 Register Definitions: Watchdog Control

REGISTER 9-1: WDTCON: WATCHDOG TIMER CONTROL REGISTER

U-0	U-0	R/W-0/0	R/W-1/1	R/W-0/0	R/W-1/1	R/W-1/1	R/W-0/0
—	—	WDTPS<4:0>				SWDTEN	
bit 7						bit 0	

Legend:

R = Readable bit	W = Writable bit	U = Unimplemented bit, read as '0'
u = Bit is unchanged	x = Bit is unknown	-n/n = Value at POR and BOR/Value at all other Resets
'1' = Bit is set	'0' = Bit is cleared	

bit 7-6 **Unimplemented:** Read as '0'

bit 5-1 **WDTPS<4:0>:** Watchdog Timer Period Select bits⁽¹⁾

Bit Value = Prescale Rate

11111 = Reserved. Results in minimum interval (1:32)

•

•

•

10011 = Reserved. Results in minimum interval (1:32)

10010 = 1:8388608 (2^{23}) (Interval 256s nominal)

10001 = 1:4194304 (2^{22}) (Interval 128s nominal)

10000 = 1:2097152 (2^{21}) (Interval 64s nominal)

01111 = 1:1048576 (2^{20}) (Interval 32s nominal)

01110 = 1:524288 (2^{19}) (Interval 16s nominal)

01101 = 1:262144 (2^{18}) (Interval 8s nominal)

01100 = 1:131072 (2^{17}) (Interval 4s nominal)

01011 = 1:65536 (Interval 2s nominal) (Reset value)

01010 = 1:32768 (Interval 1s nominal)

01001 = 1:16384 (Interval 512 ms nominal)

01000 = 1:8192 (Interval 256 ms nominal)

00111 = 1:4096 (Interval 128 ms nominal)

00110 = 1:2048 (Interval 64 ms nominal)

00101 = 1:1024 (Interval 32 ms nominal)

00100 = 1:512 (Interval 16 ms nominal)

00011 = 1:256 (Interval 8 ms nominal)

00010 = 1:128 (Interval 4 ms nominal)

00001 = 1:64 (Interval 2 ms nominal)

00000 = 1:32 (Interval 1 ms nominal)

bit 0 **SWDTEN:** Software Enable/Disable for Watchdog Timer bit

If WDTE<1:0> = 1x:

This bit is ignored.

If WDTE<1:0> = 01:

1 = WDT is turned on

0 = WDT is turned off

If WDTE<1:0> = 00:

This bit is ignored.

Note 1: Times are approximate. WDT time is based on 31 kHz LFINTOSC.

TABLE 9-3: SUMMARY OF REGISTERS ASSOCIATED WITH WATCHDOG TIMER

Name	Bit 7	Bit 6	Bit 5	Bit 4	Bit 3	Bit 2	Bit 1	Bit 0	Register on Page
OSCCON	SPLLEN	IRCF<3:0>			—		SCS<1:0>		62
PCON	STKOVF	STKUNF	—	\overline{RWDT}	\overline{RMCLR}	\overline{RI}	\overline{POR}	\overline{BOR}	70
STATUS	—	—	—	\overline{TO}	\overline{PD}	Z	DC	C	22
WDTCON	—	—	WDTPS<4:0>					SWDTEN	86

Legend: x = unknown, u = unchanged, — = unimplemented locations read as '0'. Shaded cells are not used by Watchdog Timer.

TABLE 9-4: SUMMARY OF CONFIGURATION WORD WITH WATCHDOG TIMER

Name	Bits	Bit -/7	Bit -/6	Bit 13/5	Bit 12/4	Bit 11/3	Bit 10/2	Bit 9/1	Bit 8/0	Register on Page
CONFIG1	13:8	—	—	—	—	$\overline{CLKOUTEN}$	BOREN<1:0>		—	53
	7:0	\overline{CP}	MCLRE	\overline{PWRTE}	WDTE<1:0>		—	FOSC<1:0>		

Legend: — = unimplemented location, read as '0'. Shaded cells are not used by Watchdog Timer.

PIC16LF1554/1559

10.0 FLASH PROGRAM MEMORY CONTROL

The Flash program memory is readable and writable during normal operation over the full VDD range. Program memory is indirectly addressed using Special Function Registers (SFRs). The SFRs used to access program memory are:

- PMCON1
- PMCON2
- PMDATL
- PMDATH
- PMADRL
- PMADRH

When accessing the program memory, the PMDATH:PMDATL register pair forms a 2-byte word that holds the 14-bit data for read/write, and the PMADRH:PMADRL register pair forms a 2-byte word that holds the 15-bit address of the program memory location being read.

The write time is controlled by an on-chip timer. The write/erase voltages are generated by an on-chip charge pump rated to operate over the operating voltage range of the device.

The Flash program memory can be protected in two ways; by code protection (\overline{CP} bit in Configuration Words) and write protection (WRT<1:0> bits in Configuration Words).

Code protection ($\overline{CP} = 0$)⁽¹⁾, disables access, reading and writing, to the Flash program memory via external device programmers. Code protection does not affect the self-write and erase functionality. Code protection can only be reset by a device programmer performing a Bulk Erase to the device, clearing all Flash program memory, Configuration bits and User IDs.

Write protection prohibits self-write and erase to a portion or all of the Flash program memory, as defined by the bits WRT<1:0>. Write protection does not affect a device programmers ability to read, write or erase the device.

Note 1: Code protection of the entire Flash program memory array is enabled by clearing the \overline{CP} bit of Configuration Words.

10.1 PMADRL and PMADRH Registers

The PMADRH:PMADRL register pair can address up to a maximum of 32K words of program memory. When selecting a program address value, the MSB of the address is written to the PMADRH register and the LSB is written to the PMADRL register.

10.1.1 PMCON1 AND PMCON2 REGISTERS

PMCON1 is the control register for Flash program memory accesses.

Control bits RD and WR initiate read and write, respectively. These bits cannot be cleared, only set, in software. They are cleared by hardware at completion of the read or write operation. The inability to clear the WR bit in software prevents the accidental, premature termination of a write operation.

The WREN bit, when set, will allow a write operation to occur. On power-up, the WREN bit is clear. The WRERR bit is set when a write operation is interrupted by a Reset during normal operation. In these situations, following Reset, the user can check the WRERR bit and execute the appropriate error handling routine.

The PMCON2 register is a write-only register. Attempting to read the PMCON2 register will return all '0's.

To enable writes to the program memory, a specific pattern (the unlock sequence), must be written to the PMCON2 register. The required unlock sequence prevents inadvertent writes to the program memory write latches and Flash program memory.

10.2 Flash Program Memory Overview

It is important to understand the Flash program memory structure for erase and programming operations. Flash program memory is arranged in rows. A row consists of a fixed number of 14-bit program memory words. A row is the minimum size that can be erased by user software.

After a row has been erased, the user can reprogram all or a portion of this row. Data to be written into the program memory row is written to 14-bit wide data write latches. These write latches are not directly accessible to the user, but may be loaded via sequential writes to the PMDATH:PMDATL register pair.

Note: If the user wants to modify only a portion of a previously programmed row, then the contents of the entire row must be read and saved in RAM prior to the erase. Then, new data and retained data can be written into the write latches to reprogram the row of Flash program memory. However, any unprogrammed locations can be written without first erasing the row. In this case, it is not necessary to save and rewrite the other previously programmed locations.

See [Table 10-1](#) for Erase Row size and the number of write latches for Flash program memory.

TABLE 10-1: FLASH MEMORY ORGANIZATION BY DEVICE

Device	Row Erase (words)	Write Latches (words)
PIC16LF1554	32	32
PIC16LF1559		

10.2.1 READING THE FLASH PROGRAM MEMORY

To read a program memory location, the user must:

1. Write the desired address to the PMADRH:PMADRL register pair.
2. Clear the CFGS bit of the PMCON1 register.
3. Then, set control bit RD of the PMCON1 register.

Once the read control bit is set, the program memory Flash controller will use the second instruction cycle to read the data. This causes the second instruction immediately following the “BSF PMCON1, RD” instruction to be ignored. The data is available in the very next cycle, in the PMDATH:PMDATL register pair; therefore, it can be read as two bytes in the following instructions.

PMDATH:PMDATL register pair will hold this value until another read or until it is written to by the user.

Note: The two instructions following a program memory read are required to be NOPs. This prevents the user from executing a 2-cycle instruction on the next instruction after the RD bit is set.

FIGURE 10-1: FLASH PROGRAM MEMORY READ FLOWCHART

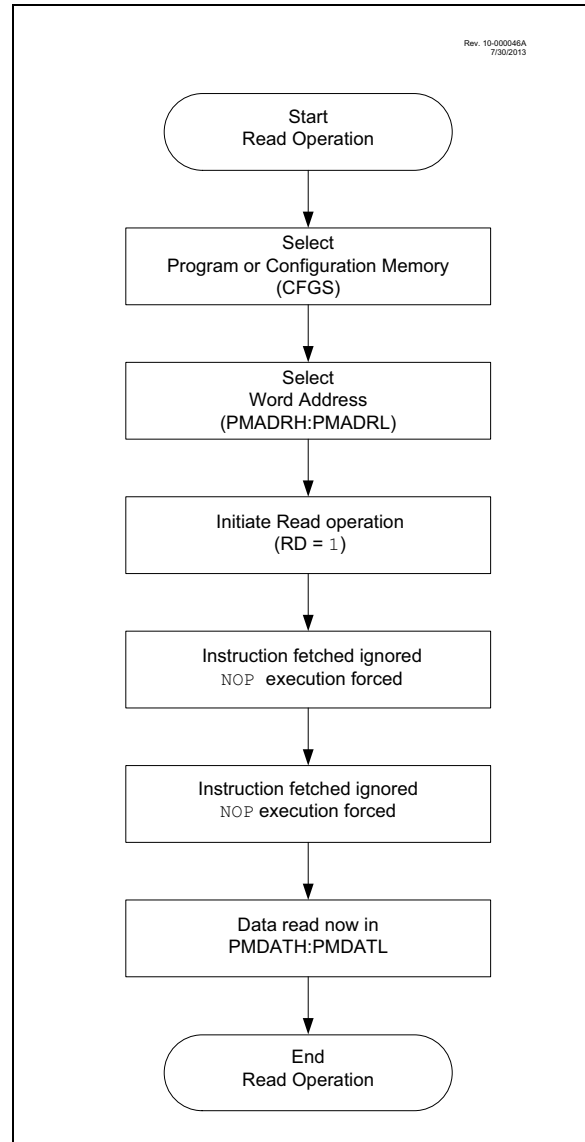

PIC16LF1554/1559

FIGURE 10-2: FLASH PROGRAM MEMORY READ CYCLE EXECUTION

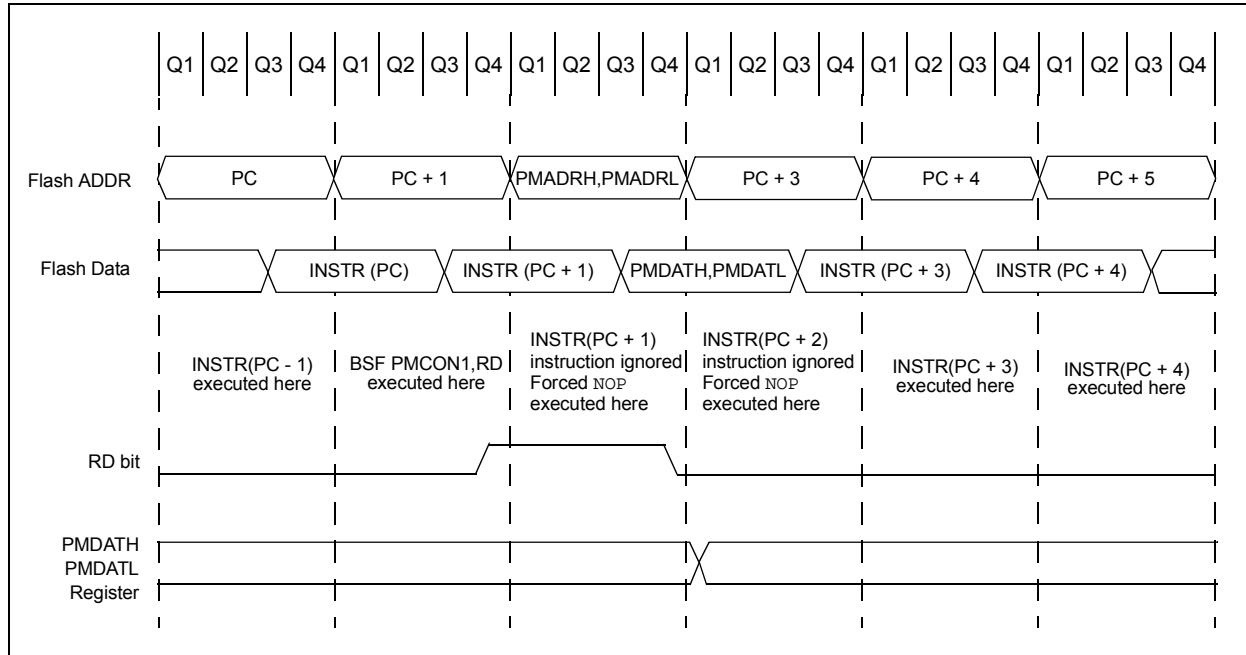

EXAMPLE 10-1: FLASH PROGRAM MEMORY READ

```

* This code block will read 1 word of program
* memory at the memory address:
  PROG_ADDR_HI : PROG_ADDR_LO
* data will be returned in the variables;
*  PROG_DATA_HI, PROG_DATA_LO

  BANKSEL  PMADRL          ; Select Bank for PMCON registers
  MOVLW   PROG_ADDR_LO    ;
  MOVWF   PMADRL          ; Store LSB of address
  MOVLW   PROG_ADDR_HI    ;
  MOVWF   PMADRH          ; Store MSB of address

  BCF     PMCON1,CFGS     ; Do not select Configuration Space
  BSF     PMCON1,RD       ; Initiate read
  NOP     ; Ignored (Figure 10-2)
  NOP     ; Ignored (Figure 10-2)

  MOVF    PMDATL,W        ; Get LSB of word
  MOVWF   PROG_DATA_LO   ; Store in user location
  MOVF    PMDATH,W        ; Get MSB of word
  MOVWF   PROG_DATA_HI   ; Store in user location

```

10.2.2 FLASH MEMORY UNLOCK SEQUENCE

The unlock sequence is a mechanism that protects the Flash program memory from unintended self-write programming or erasing. The sequence must be executed and completed without interruption to successfully complete any of the following operations:

- Row Erase
- Load program memory write latches
- Write of program memory write latches to program memory
- Write of program memory write latches to User IDs

The unlock sequence consists of the following steps:

1. Write 55h to PMCON2
2. Write AAh to PMCON2
3. Set the WR bit in PMCON1
4. NOP instruction
5. NOP instruction

Once the WR bit is set, the processor will always force two NOP instructions. When an Erase Row or Program Row operation is being performed, the processor will stall internal operations (typical 2 ms), until the operation is complete and then resume with the next instruction. When the operation is loading the program memory write latches, the processor will always force the two NOP instructions and continue uninterrupted with the next instruction.

Since the unlock sequence must not be interrupted, global interrupts should be disabled prior to the unlock sequence and re-enabled after the unlock sequence is completed.

FIGURE 10-3: FLASH PROGRAM MEMORY UNLOCK SEQUENCE FLOWCHART

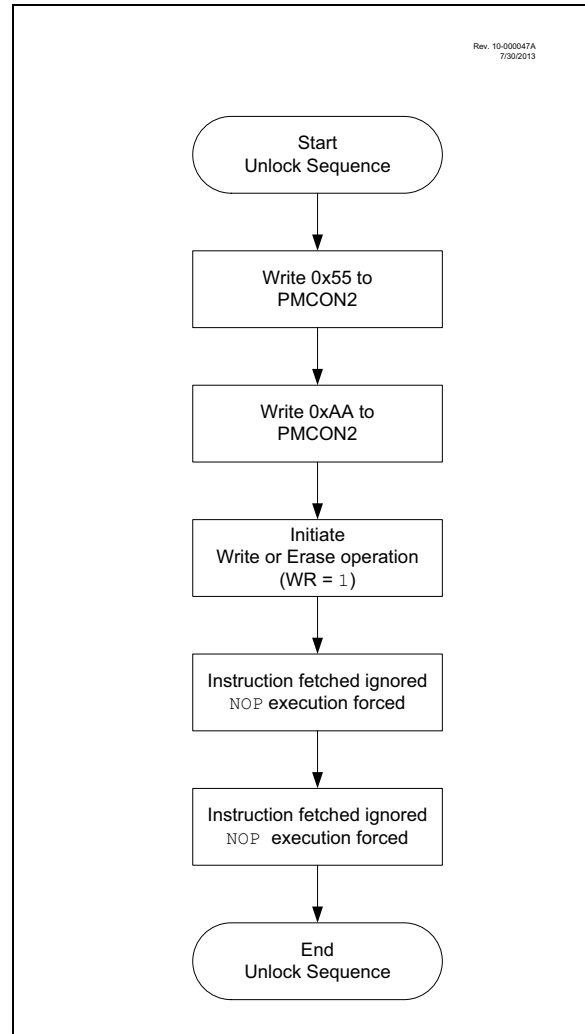

PIC16LF1554/1559

10.2.3 ERASING FLASH PROGRAM MEMORY

While executing code, program memory can only be erased by rows. To erase a row:

1. Load the PMADRH:PMADRL register pair with any address within the row to be erased.
2. Clear the CFGS bit of the PMCON1 register.
3. Set the FREE and WREN bits of the PMCON1 register.
4. Write 55h, then AAh, to PMCON2 (Flash programming unlock sequence).
5. Set control bit WR of the PMCON1 register to begin the erase operation.

See [Example 10-2](#).

After the “BSF PMCON1, WR” instruction, the processor requires two cycles to set up the erase operation. The user must place two NOP instructions immediately following the WR bit set instruction. The processor will halt internal operations for the typical 2 ms erase time. This is not Sleep mode as the clocks and peripherals will continue to run. After the erase cycle, the processor will resume operation with the third instruction after the PMCON1 write instruction.

FIGURE 10-4: FLASH PROGRAM MEMORY ERASE FLOWCHART

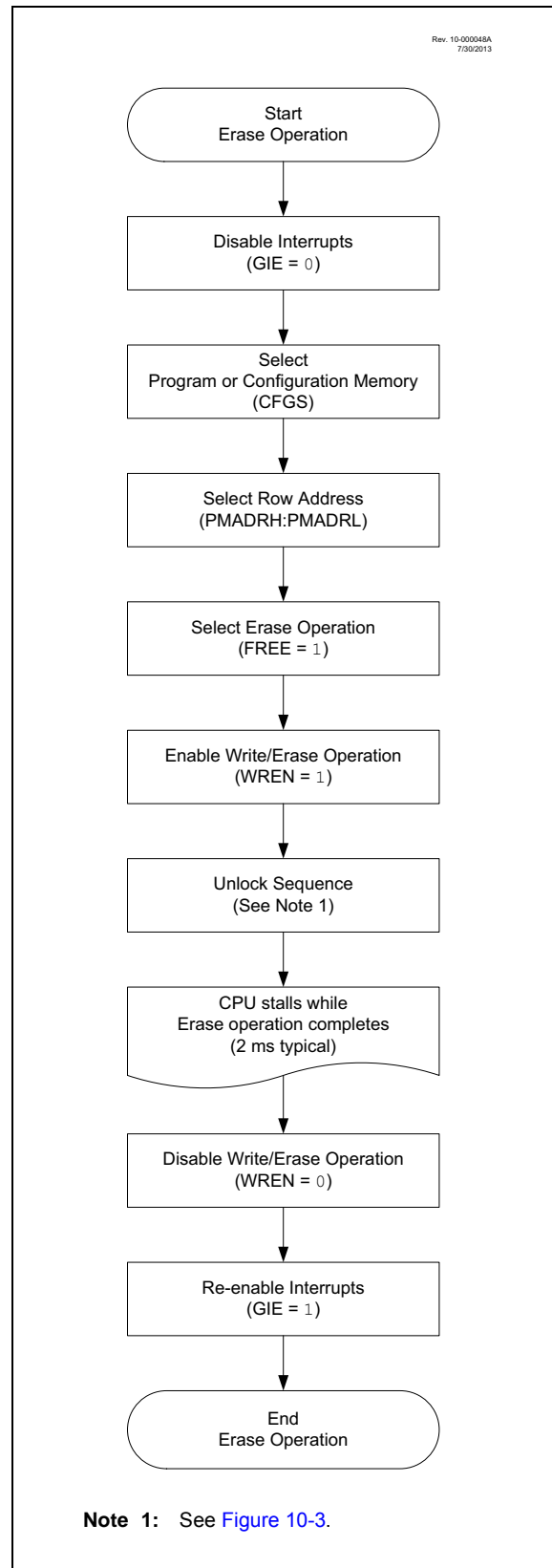

EXAMPLE 10-2: ERASING ONE ROW OF PROGRAM MEMORY

```

; This row erase routine assumes the following:
; 1. A valid address within the erase row is loaded in ADDRH:ADDRL
; 2. ADDRH and ADDRL are located in shared data memory 0x70 - 0x7F (common RAM)

        BCF      INTCON,GIE      ; Disable ints so required sequences will execute properly
        BANKSEL PMADRL
        MOVF     ADDRL,W         ; Load lower 8 bits of erase address boundary
        MOVWF   PMADRL
        MOVF     ADDRH,W        ; Load upper 6 bits of erase address boundary
        MOVWF   PMADRH
        BCF      PMCON1,CFG5     ; Not configuration space
        BSF      PMCON1,FREE     ; Specify an erase operation
        BSF      PMCON1,WREN     ; Enable writes

        MOVLW   55h             ; Start of required sequence to initiate erase
        MOVWF   PMCON2          ; Write 55h
        MOVLW   0AAh           ;
        MOVWF   PMCON2          ; Write AAh
        BSF      PMCON1,WR      ; Set WR bit to begin erase
        NOP
        NOP                     ; NOP instructions are forced as processor starts
        NOP                     ; row erase of program memory.
        ;
        ; The processor stalls until the erase process is complete
        ; after erase processor continues with 3rd instruction

        BCF      PMCON1,WREN     ; Disable writes
        BSF      INTCON,GIE     ; Enable interrupts
    
```

Required Sequence

PIC16LF1554/1559

10.2.4 WRITING TO FLASH PROGRAM MEMORY

Program memory is programmed using the following steps:

1. Load the address in PMADRH:PMADRL of the row to be programmed.
2. Load each write latch with data.
3. Initiate a programming operation.
4. Repeat steps 1 through 3 until all data is written.

Before writing to program memory, the word(s) to be written must be erased or previously unwritten. Program memory can only be erased one row at a time. No automatic erase occurs upon the initiation of the write.

Program memory can be written one or more words at a time. The maximum number of words written at one time is equal to the number of write latches. See [Figure 10-5](#) (row writes to program memory with 32 write latches) for more details.

The write latches are aligned to the Flash row address boundary defined by the upper 10-bits of PMADRH:PMADRL, (PMADRH<6:0>:PMADRL<7:5>) with the lower five bits of PMADRL, (PMADRL<4:0>) determining the write latch being loaded. Write operations do not cross these boundaries. At the completion of a program memory write operation, the data in the write latches is reset to contain 0x3FFF.

The following steps should be completed to load the write latches and program a row of program memory. These steps are divided into two parts. First, each write latch is loaded with data from the PMDATH:PMDATL using the unlock sequence with LWLO = 1. When the last word to be loaded into the write latch is ready, the LWLO bit is cleared and the unlock sequence executed. This initiates the programming operation, writing all the latches into Flash program memory.

Note: The special unlock sequence is required to load a write latch with data or initiate a Flash programming operation. If the unlock sequence is interrupted, writing to the latches or program memory will not be initiated.

1. Set the WREN bit of the PMCON1 register.
2. Clear the CFGS bit of the PMCON1 register.
3. Set the LWLO bit of the PMCON1 register. When the LWLO bit of the PMCON1 register is '1', the write sequence will only load the write latches and will not initiate the write to Flash program memory.
4. Load the PMADRH:PMADRL register pair with the address of the location to be written.
5. Load the PMDATH:PMDATL register pair with the program memory data to be written.
6. Execute the unlock sequence ([Section 10.2.2 "Flash Memory Unlock Sequence"](#)). The write latch is now loaded.
7. Increment the PMADRH:PMADRL register pair to point to the next location.
8. Repeat steps 5 through 7 until all but the last write latch has been loaded.
9. Clear the LWLO bit of the PMCON1 register. When the LWLO bit of the PMCON1 register is '0', the write sequence will initiate the write to Flash program memory.
10. Load the PMDATH:PMDATL register pair with the program memory data to be written.
11. Execute the unlock sequence ([Section 10.2.2 "Flash Memory Unlock Sequence"](#)). The entire program memory latch content is now written to Flash program memory.

Note: The program memory write latches are reset to the blank state (0x3FFF) at the completion of every write or erase operation. As a result, it is not necessary to load all the program memory write latches. Unloaded latches will remain in the blank state.

An example of the complete write sequence is shown in [Example 10-3](#). The initial address is loaded into the PMADRH:PMADRL register pair; the data is loaded using indirect addressing.

FIGURE 10-5: BLOCK WRITES TO FLASH PROGRAM MEMORY WITH 32 WRITE LATCHES

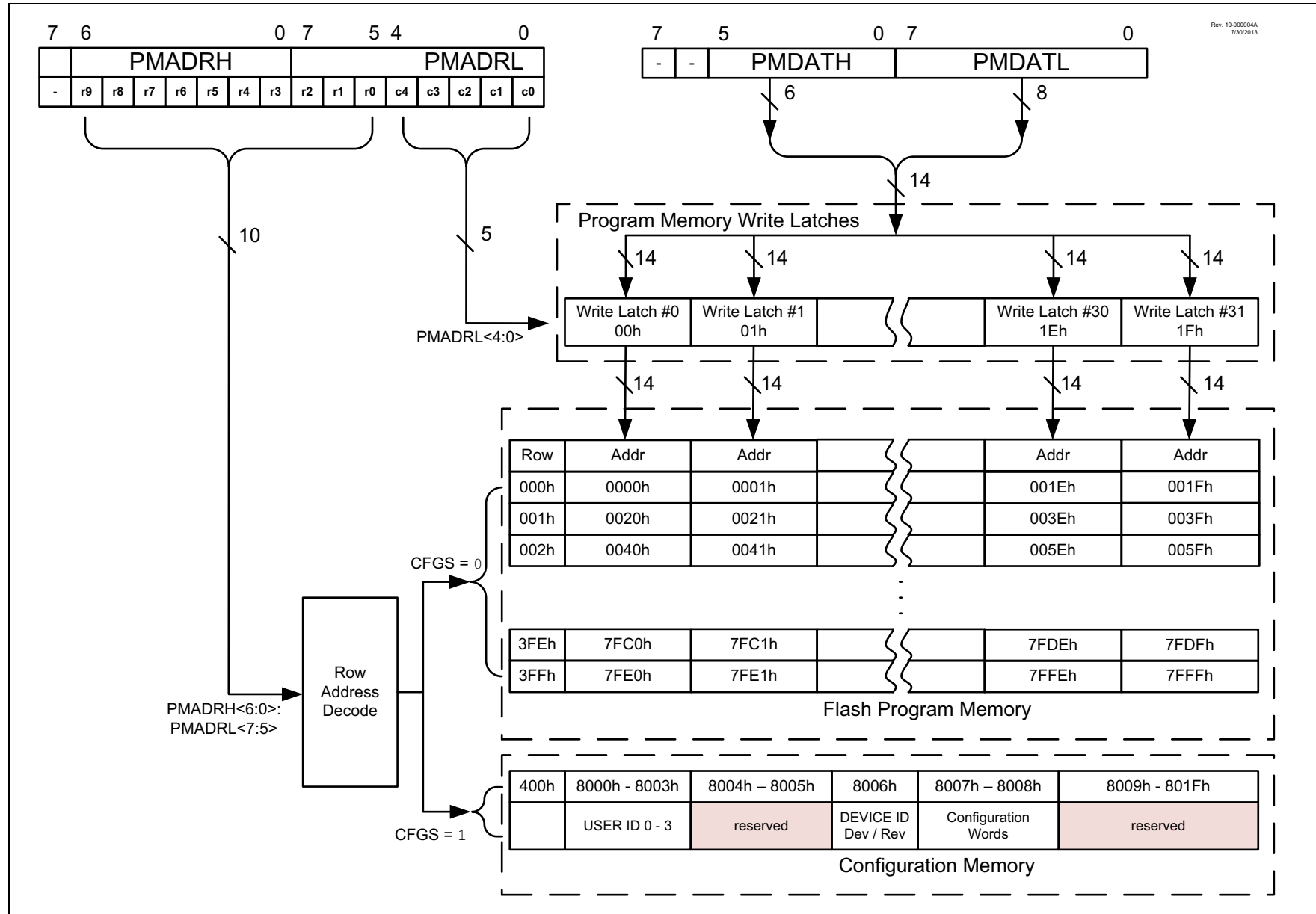

PIC16LF1554/1559

FIGURE 10-6: FLASH PROGRAM MEMORY WRITE FLOWCHART

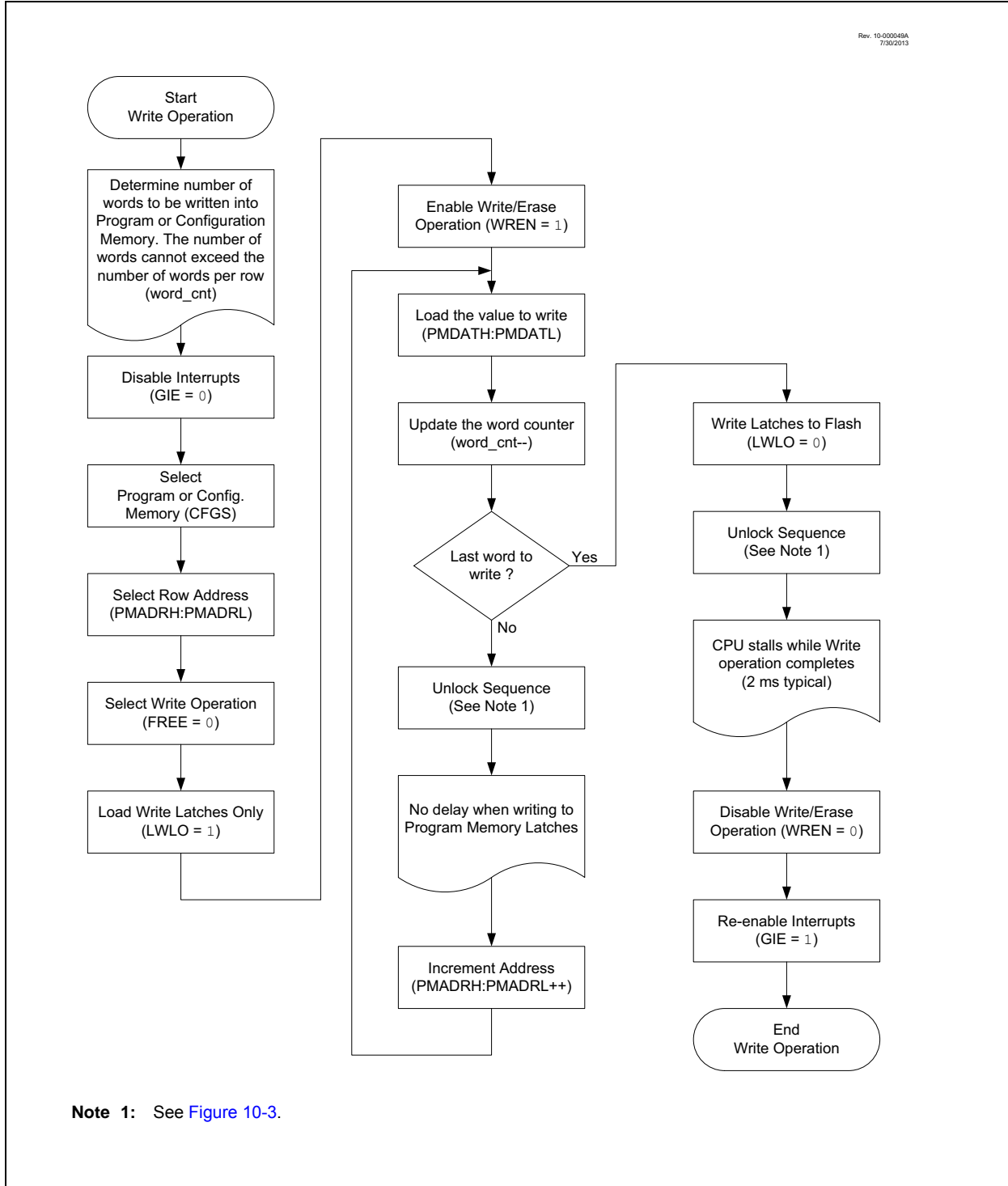

EXAMPLE 10-3: WRITING TO FLASH PROGRAM MEMORY (32 WRITE LATCHES)

```

; This write routine assumes the following:
; 1. 64 bytes of data are loaded, starting at the address in DATA_ADDR
; 2. Each word of data to be written is made up of two adjacent bytes in DATA_ADDR,
;    stored in little endian format
; 3. A valid starting address (the Least Significant bits = 00000) is loaded in ADDRH:ADDRL
; 4. ADDRH and ADDRL are located in shared data memory 0x70 - 0x7F (common RAM)
;
    BCF      INTCON,GIE      ; Disable ints so required sequences will execute properly
    BANKSEL PMADRH         ; Bank 3
    MOVF    ADDRH,W        ; Load initial address
    MOVWF   PMADRH        ;
    MOVF    ADDRL,W       ;
    MOVWF   PMADRL       ;
    MOVLW   LOW DATA_ADDR ; Load initial data address
    MOVWF   FSR0L        ;
    MOVLW   HIGH DATA_ADDR ; Load initial data address
    MOVWF   FSR0H        ;
    BCF     PMCON1,CFG5    ; Not configuration space
    BSF     PMCON1,WREN    ; Enable writes
    BSF     PMCON1,LWLO    ; Only Load Write Latches

LOOP
    MOVIW   FSR0++        ; Load first data byte into lower
    MOVWF   PMDATL       ;
    MOVIW   FSR0++        ; Load second data byte into upper
    MOVWF   PMDATH       ;

    MOVF    PMADRL,W     ; Check if lower bits of address are '00000'
    XORLW   0x1F         ; Check if we're on the last of 32 addresses
    ANDLW   0x1F         ;
    BTFSC   STATUS,Z     ; Exit if last of 32 words,
    GOTO    START_WRITE  ;

    Required Sequence
    MOVLW   55h          ; Start of required write sequence:
    MOVWF   PMCON2      ; Write 55h
    MOVLW   0AAh        ;
    MOVWF   PMCON2      ; Write AAh
    BSF     PMCON1,WR    ; Set WR bit to begin write
    NOP     ; NOP instructions are forced as processor
             ; loads program memory write latches
    NOP     ;

    INCF    PMADRL,F     ; Still loading latches Increment address
    GOTO    LOOP        ; Write next latches

START_WRITE
    BCF     PMCON1,LWLO  ; No more loading latches - Actually start Flash program
                     ; memory write

    Required Sequence
    MOVLW   55h          ; Start of required write sequence:
    MOVWF   PMCON2      ; Write 55h
    MOVLW   0AAh        ;
    MOVWF   PMCON2      ; Write AAh
    BSF     PMCON1,WR    ; Set WR bit to begin write
    NOP     ; NOP instructions are forced as processor writes
             ; all the program memory write latches simultaneously
             ; to program memory.
    NOP     ;
             ; After NOPs, the processor
             ; stalls until the self-write process is complete
             ; after write processor continues with 3rd instruction

    BCF     PMCON1,WREN  ; Disable writes
    BSF     INTCON,GIE   ; Enable interrupts

```

10.3 Modifying Flash Program Memory

When modifying existing data in a program memory row, and data within that row must be preserved, it must first be read and saved in a RAM image. Program memory is modified using the following steps:

1. Load the starting address of the row to be modified.
2. Read the existing data from the row into a RAM image.
3. Modify the RAM image to contain the new data to be written into program memory.
4. Load the starting address of the row to be rewritten.
5. Erase the program memory row.
6. Load the write latches with data from the RAM image.
7. Initiate a programming operation.

FIGURE 10-7: FLASH PROGRAM MEMORY MODIFY FLOWCHART

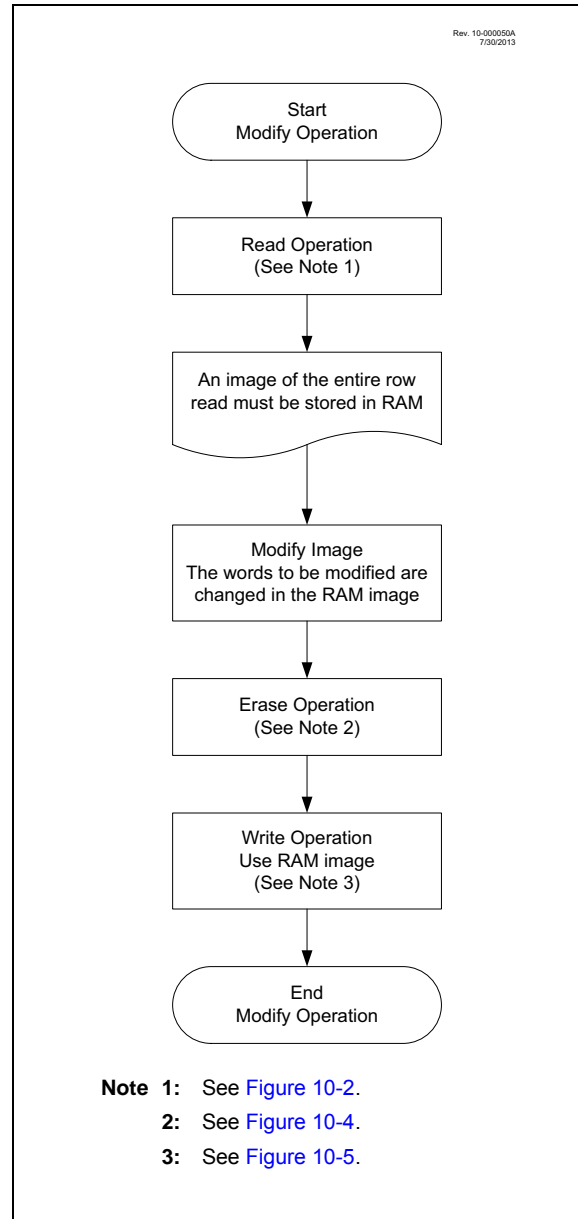

10.4 User ID, Device ID and Configuration Word Access

Instead of accessing program memory, the User ID's, Device ID/Revision ID and Configuration Words can be accessed when $CFGS = 1$ in the PMCON1 register. This is the region that would be pointed to by $PC<15> = 1$, but not all addresses are accessible. Different access may exist for reads and writes. Refer to [Table 10-2](#).

When read access is initiated on an address outside the parameters listed in [Table 10-2](#), the PMDATH:PMDATL register pair is cleared, reading back '0's.

TABLE 10-2: USER ID, DEVICE ID AND CONFIGURATION WORD ACCESS (CFGS = 1)

Address	Function	Read Access	Write Access
8000h-8003h	User IDs	Yes	Yes
8006h	Device ID/Revision ID	Yes	No
8007h-8008h	Configuration Words 1 and 2	Yes	No

EXAMPLE 10-4: CONFIGURATION WORD AND DEVICE ID ACCESS

```

* This code block will read 1 word of program memory at the memory address:
*   PROG_ADDR_LO (must be 00h-08h) data will be returned in the variables;
*   PROG_DATA_HI, PROG_DATA_LO

    BANKSEL    PMADRL        ; Select correct Bank
    MOVLW     PROG_ADDR_LO   ;
    MOVWF    PMADRL        ; Store LSB of address
    CLRF     PMADRH        ; Clear MSB of address

    BSF      PMCON1,CFGS    ; Select Configuration Space
    BCF      INTCON,GIE     ; Disable interrupts
    BSF      PMCON1,RD     ; Initiate read
    NOP
    NOP      ; Executed (See Figure 10-2)
    NOP      ; Ignored (See Figure 10-2)
    BSF      INTCON,GIE    ; Restore interrupts

    MOVF     PMDATL,W       ; Get LSB of word
    MOVWF    PROG_DATA_LO  ; Store in user location
    MOVF     PMDATH,W      ; Get MSB of word
    MOVWF    PROG_DATA_HI  ; Store in user location
    
```

PIC16LF1554/1559

10.5 Write Verify

It is considered good programming practice to verify that program memory writes agree with the intended value. Since program memory is stored as a full page then the stored program memory contents are compared with the intended data stored in RAM after the last write is complete.

FIGURE 10-8: FLASH PROGRAM MEMORY VERIFY FLOWCHART

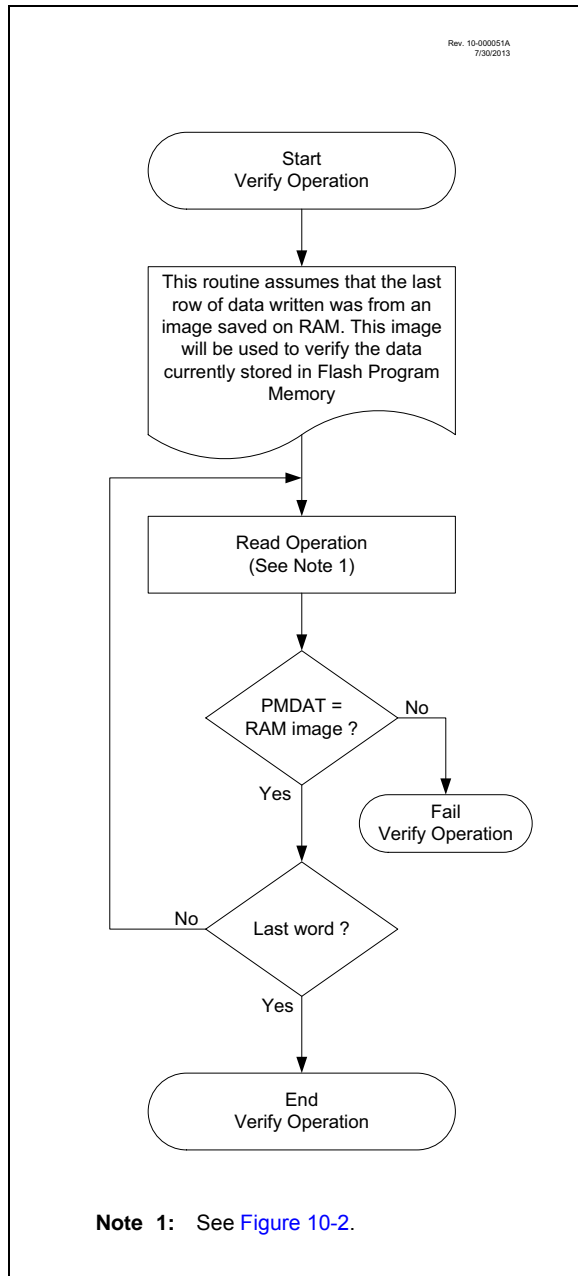

10.6 Register Definitions: Flash Program Memory Control

REGISTER 10-1: PMDATL: PROGRAM MEMORY DATA LOW BYTE REGISTER

R/W-x/u	R/W-x/u	R/W-x/u	R/W-x/u	R/W-x/u	R/W-x/u	R/W-x/u	R/W-x/u
PMDAT<7:0>							
bit 7							bit 0

Legend:

R = Readable bit	W = Writable bit	U = Unimplemented bit, read as '0'
u = Bit is unchanged	x = Bit is unknown	-n/n = Value at POR and BOR/Value at all other Resets
'1' = Bit is set	'0' = Bit is cleared	

bit 7-0 **PMDAT<7:0>**: Read/write value for Least Significant bits of program memory

REGISTER 10-2: PMDATH: PROGRAM MEMORY DATA HIGH BYTE REGISTER

U-0	U-0	R/W-x/u	R/W-x/u	R/W-x/u	R/W-x/u	R/W-x/u	R/W-x/u
—		PMDAT<13:8>					
bit 7							bit 0

Legend:

R = Readable bit	W = Writable bit	U = Unimplemented bit, read as '0'
u = Bit is unchanged	x = Bit is unknown	-n/n = Value at POR and BOR/Value at all other Resets
'1' = Bit is set	'0' = Bit is cleared	

bit 7-6 **Unimplemented**: Read as '0'

bit 5-0 **PMDAT<13:8>**: Read/write value for Most Significant bits of program memory

PIC16LF1554/1559

REGISTER 10-3: PMADRL: PROGRAM MEMORY ADDRESS LOW BYTE REGISTER

R/W-0/0	R/W-0/0	R/W-0/0	R/W-0/0	R/W-0/0	R/W-0/0	R/W-0/0	R/W-0/0
PMADR<7:0>							
bit 7							bit 0

Legend:

R = Readable bit	W = Writable bit	U = Unimplemented bit, read as '0'
u = Bit is unchanged	x = Bit is unknown	-n/n = Value at POR and BOR/Value at all other Resets
'1' = Bit is set	'0' = Bit is cleared	

bit 7-0 **PMADR<7:0>**: Specifies the Least Significant bits for program memory address

REGISTER 10-4: PMADRH: PROGRAM MEMORY ADDRESS HIGH BYTE REGISTER

U-1	R/W-0/0	R/W-0/0	R/W-0/0	R/W-0/0	R/W-0/0	R/W-0/0	R/W-0/0
—	PMADR<14:8>						
bit 7							bit 0

Legend:

R = Readable bit	W = Writable bit	U = Unimplemented bit, read as '0'
u = Bit is unchanged	x = Bit is unknown	-n/n = Value at POR and BOR/Value at all other Resets
'1' = Bit is set	'0' = Bit is cleared	

bit 7 **Unimplemented**: Read as '1'

bit 6-0 **PMADR<14:8>**: Specifies the Most Significant bits for program memory address

REGISTER 10-5: PMCON1: PROGRAM MEMORY CONTROL 1 REGISTER

U-1	R/W-0/0	R/W-0/0	R/W/HC-0/0	R/W/HC-x/q	R/W-0/0	R/S/HC-0/0	R/S/HC-0/0
—	CFGS	LWLO	FREE	WRERR	WREN	WR	RD
bit 7							bit 0

Legend:

R = Readable bit	W = Writable bit	U = Unimplemented bit, read as '0'
S = Bit can only be set	x = Bit is unknown	-n/n = Value at POR and BOR/Value at all other Resets
'1' = Bit is set	'0' = Bit is cleared	HC = Bit is cleared by hardware

- bit 7 **Unimplemented:** Read as '1'
- bit 6 **CFGS:** Configuration Select bit
 1 = Access Configuration, User ID and Device ID Registers
 0 = Access Flash program memory
- bit 5 **LWLO:** Load Write Latches Only bit⁽¹⁾
 1 = Only the addressed program memory write latch is loaded/updated on the next WR command
 0 = The addressed program memory write latch is loaded/updated and a write of all program memory write latches will be initiated on the next WR command
- bit 4 **FREE:** Program Flash Erase Enable bit
 1 = Performs an erase operation on the next WR command (hardware cleared upon completion)
 0 = Performs a write operation on the next WR command
- bit 3 **WRERR:** Program/Erase Error Flag bit⁽²⁾
 1 = Condition indicates an improper program or erase sequence attempt or termination (bit is set automatically on any set attempt (write '1') of the WR bit).
 0 = The program or erase operation completed normally.
- bit 2 **WREN:** Program/Erase Enable bit
 1 = Allows program/erase cycles
 0 = Inhibits programming/erasing of program Flash
- bit 1 **WR:** Write Control bit
 1 = Initiates a program Flash program/erase operation.
 The operation is self-timed and the bit is cleared by hardware once operation is complete.
 The WR bit can only be set (not cleared) in software.
 0 = Program/erase operation to the Flash is complete and inactive.
- bit 0 **RD:** Read Control bit
 1 = Initiates a program Flash read. Read takes one cycle. RD is cleared in hardware. The RD bit can only be set (not cleared) in software.
 0 = Does not initiate a program Flash read.

Note 1: The LWLO bit is ignored during a program memory erase operation (FREE = 1).

Note 2: The WRERR bit is automatically set by hardware when a program memory write or erase operation is started (WR = 1).

PIC16LF1554/1559

REGISTER 10-6: PMCON2: PROGRAM MEMORY CONTROL 2 REGISTER

W-0/0	W-0/0	W-0/0	W-0/0	W-0/0	W-0/0	W-0/0	W-0/0	W-0/0
Program Memory Control Register 2								
bit 7								bit 0

Legend:

R = Readable bit W = Writable bit U = Unimplemented bit, read as '0'
S = Bit can only be set x = Bit is unknown -n/n = Value at POR and BOR/Value at all other Resets
'1' = Bit is set '0' = Bit is cleared

bit 7-0 Flash Memory Unlock Pattern bits

To unlock writes, a 55h must be written first, followed by an AAh, before setting the WR bit of the PMCON1 register. The value written to this register is used to unlock the writes. There are specific timing requirements on these writes.

TABLE 10-3: SUMMARY OF REGISTERS ASSOCIATED WITH FLASH PROGRAM MEMORY

Name	Bit 7	Bit 6	Bit 5	Bit 4	Bit 3	Bit 2	Bit 1	Bit 0	Register on Page
INTCON	GIE	PEIE	TMR0IE	INTE	IOCIE	TMR0IF	INTF	IOCIF	77
PMCON1	— ⁽¹⁾	CFG5	LWLO	FREE	WRERR	WREN	WR	RD	103
PMCON2	Program Memory Control Register 2								104
PMADRL	PMADR<7:0>								102
PMADRH	— ⁽¹⁾	PMADR<14:8>							102
PMDATL	PMDAT<7:0>								101
PMDATH	—	—	PMDAT<13:8>						101

Legend: — = unimplemented location, read as '0'. Shaded cells are not used by Flash program memory.

Note 1: Unimplemented, read as '1'.

TABLE 10-4: SUMMARY OF CONFIGURATION WORD WITH FLASH PROGRAM MEMORY

Name	Bits	Bit -/7	Bit -/6	Bit 13/5	Bit 12/4	Bit 11/3	Bit 10/2	Bit 9/1	Bit 8/0	Register on Page
CONFIG1	13:8	—	—	—	—	CLKOUTEN	BOREN<1:0>		—	53
	7:0	CP	MCLRE	PWRTÉ	WDTE<1:0>		—	FOSC<1:0>		
CONFIG2	13:8	—	—	LVP	DEBUG	LPBOR	BORV	STVREN	—	54
	7:0	—	—	—	—	—	—	WRT<1:0>		

Legend: — = unimplemented location, read as '0'. Shaded cells are not used by Flash program memory.

11.0 I/O PORTS

Each port has three standard registers for its operation. These registers are:

- TRISx registers (data direction)
- PORTx registers (reads the levels on the pins of the device)
- LATx registers (output latch)

Some ports may have one or more of the following additional registers. These registers are:

- ANSELx (analog select)
- WPUx (weak pull-up)

In general, when a peripheral is enabled on a port pin, that pin cannot be used as a general purpose output. However, the pin can still be read.

TABLE 11-1: PORT AVAILABILITY PER DEVICE

Device	PORTA	PORTB	PORTC
PIC16LF1554	•	•	•
PIC16LF1559	•	•	•

The data latch (LATx registers) is useful for read-modify-write operations on the value that the I/O pins are driving.

A write operation to the LATx register has the same effect as a write to the corresponding PORTx register. A read of the LATx register reads of the values held in the I/O PORT latches, while a read of the PORTx register reads the actual I/O pin value.

Ports that support analog inputs have an associated ANSELx register. When an ANSELx bit is set, the digital input buffer associated with that bit is disabled. Disabling the input buffer prevents analog signal levels on the pin between a logic high and low from causing excessive current in the logic input circuitry. A simplified model of a generic I/O port, without the interfaces to other peripherals, is shown in [Figure 11-1](#).

FIGURE 11-1: GENERIC I/O PORT OPERATION

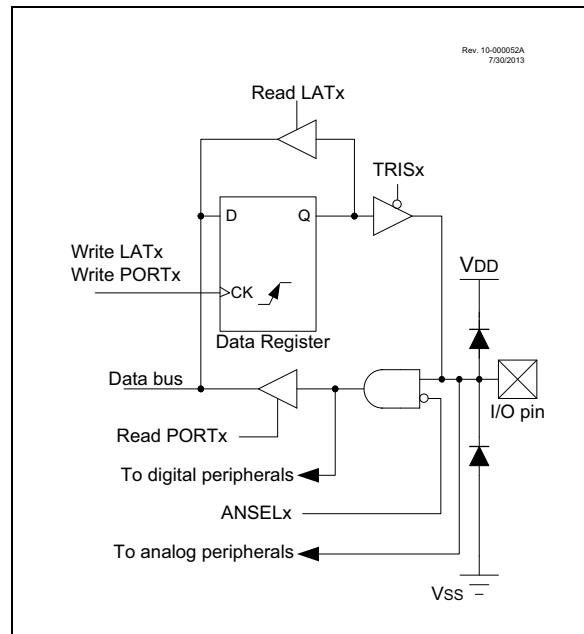

11.1 Alternate Pin Function

The Alternate Pin Function Control (APFCON) register is used to steer specific peripheral input and output functions between different pins. The APFCON register is shown in [Register 11-1](#). For this device family, the following functions can be moved between different pins.

- SS
- RX/DT
- TX/CK
- SDO
- SDA
- AD1GRDA
- AD1GRDB
- AD2GRDA
- AD2GRDB

These bits have no effect on the values of any TRISx register. PORTx and TRISx overrides will be routed to the correct pin. The unselected pin will be unaffected.

PIC16LF1554/1559

11.2 Register Definitions: Alternate Pin Function Control

REGISTER 11-1: APFCON: ALTERNATE PIN FUNCTION CONTROL REGISTER

R/W-0/0	R/W-0/0	R/W-0/0	R/W-0/0	U-0	R/W-0/0	R/W-0/0	R/W-0/0
RXDTSEL	SDOSEL	SSSEL	SDSEL	—	TXCKSEL	GRDBSEL	GRDASEL
bit 7							bit 0

Legend:

R = Readable bit	W = Writable bit	U = Unimplemented bit, read as '0'
u = Bit is unchanged	x = Bit is unknown	-n/n = Value at POR and BOR/Value at all other Resets
'1' = Bit is set	'0' = Bit is cleared	

- bit 7 **RXDTSEL:** Pin Selection bit⁽¹⁾
 0 = RX/DT function is on RC5
 1 = RX/DT function is on RA4
- bit 6 **SDOSEL:** Pin Selection bit⁽¹⁾
 0 = SDO function is on RC2
 1 = SDO function is on RA4
- bit 5 **SSSEL:** Pin Selection bit
 For 14 Pin Device (PIC16LF1554):
 0 = \overline{SS} function is on RA3
 1 = \overline{SS} function is on RC3
 For 20 Pin Device (PIC16LF1559):
 0 = \overline{SS} function is on RA3
 1 = \overline{SS} function is on RC6
- bit 4 **SDSEL:** Pin Selection bit
 For 14 Pin Device (PIC16LF1554):
 0 = SDA / SDI function is on RC1
 1 = SDA / SDI function is on RA3
 For 20 Pin Device (PIC16LF1559):
 0 = SDA / SDI function is on RB4
 1 = SDA / SDI function is on RA3
- bit 3 **Unimplemented:** Read as '0'
- bit 2 **TXCKSEL:** Pin Selection bit⁽¹⁾
 0 = TX/CK function is on RC4
 1 = TX/CK function is on RC3
- bit 1 **GRDBSEL:** Pin Selection bit
 0 = AD1GRDB function is on RC2, AD2GRDB function is on RC3
 1 = AD1GRDB function is on RC3, AD2GRDB function is on RC2
- bit 0 **GRDASEL:** Pin Selection bit
 0 = AD1GRDA function is on RC4, AD2GRDA function is on RC5
 1 = AD1GRDA function is on RC5, AD2GRDA function is on RC4

Note 1: Bit only implemented on PIC16LF1554.

11.3 PORTA Registers

11.3.1 DATA REGISTER

PORTA is a 6-bit wide, bidirectional port. The corresponding data direction register is TRISA (Register 11-3). Setting a TRISA bit (= 1) will make the corresponding PORTA pin an input (i.e., disable the output driver). Clearing a TRISA bit (= 0) will make the corresponding PORTA pin an output (i.e., enables output driver and puts the contents of the output latch on the selected pin). The exception is RA3, which is input-only and its TRISx bit will always read as '1'. Example 11-1 shows how to initialize an I/O port.

Reading the PORTA register (Register 11-2) reads the status of the pins, whereas writing to it will write to the PORT latch. All write operations are read-modify-write operations. Therefore, a write to a port implies that the port pins are read, this value is modified and then written to the PORT data latch (LATA).

11.3.2 DIRECTION CONTROL

The TRISA register (Register 11-3) controls the PORTA pin output drivers, even when they are being used as analog inputs. The user should ensure the bits in the TRISA register are maintained set when using them as analog inputs. I/O pins configured as analog input always read '0'.

11.3.3 ANALOG CONTROL

The ANSELA register (Register 11-5) is used to configure the Input mode of an I/O pin to analog. Setting the appropriate ANSELA bit high will cause all digital reads on the pin to be read as '0' and allow analog functions on the pin to operate correctly.

The state of the ANSELA bits has no effect on digital output functions. A pin with TRIS clear and ANSEL set will still operate as a digital output, but the Input mode will be analog. This can cause unexpected behavior when executing read-modify-write instructions on the affected port.

Note: The ANSELA bits default to the Analog mode after Reset. To use any pins as digital general purpose or peripheral inputs, the corresponding ANSELx bits must be initialized to '0' by user software.

EXAMPLE 11-1: INITIALIZING PORTA

```
BANKSEL PORTA      ;
CLRF PORTA         ;Init PORTA
BANKSEL LATA       ;Data Latch
CLRF LATA          ;
BANKSEL ANSELA    ;
CLRF ANSELA       ;digital I/O
BANKSEL TRISA     ;
MOVLW B'00111000' ;Set RA<5:3> as inputs
MOVWF TRISA       ;and set RA<2:0> as
                  ;outputs
```

11.3.4 PORTA FUNCTIONS AND OUTPUT PRIORITIES

Each PORTA pin is multiplexed with other functions. The pins, their combined functions and their output priorities are shown in Table 11-2.

When multiple outputs are enabled, the actual pin control goes to the peripheral with the highest priority.

Analog input functions, such as ADC and comparator inputs, are not shown in the priority lists. These inputs are active when the I/O pin is set for Analog mode using the ANSELx registers. Digital output functions may control the pin when it is in Analog mode with the priority shown below in Table 11-2.

TABLE 11-2: PORTA OUTPUT PRIORITY

Pin Name	Function Priority ⁽¹⁾
RA0	ICSPDAT RA0
RA1	RA1
RA2	RA2
RA3	RA3
RA4	CLKOUT RA4
RA5	RA5

Note 1: Priority listed from highest to lowest.

PIC16LF1554/1559

11.4 Register Definitions: PORTA

REGISTER 11-2: PORTA: PORTA REGISTER

U-0	U-0	R/W-x/x	R/W-x/x	R-x/x	R/W-x/x	R/W-x/x	R/W-x/x
—	—	RA5	RA4	RA3	RA2	RA1	RA0
bit 7							bit 0

Legend:

R = Readable bit W = Writable bit U = Unimplemented bit, read as '0'
u = Bit is unchanged x = Bit is unknown -n/n = Value at POR and BOR/Value at all other Resets
'1' = Bit is set '0' = Bit is cleared

bit 7-6 **Unimplemented:** Read as '0'
bit 5-0 **RA<5:0>:** PORTA I/O Value bits⁽¹⁾
 1 = Port pin is $\geq V_{IH}$
 0 = Port pin is $\leq V_{IL}$

Note 1: Writes to PORTA are actually written to corresponding LATA register. Reads from PORTA register is return of actual I/O pin values.

REGISTER 11-3: TRISA: PORTA TRI-STATE REGISTER

U-0	U-0	R/W-1/1	R/W-1/1	U-1	R/W-1/1	R/W-1/1	R/W-1/1
—	—	TRISA5	TRISA4	—	TRISA2	TRISA1	TRISA0
bit 7							bit 0

Legend:

R = Readable bit W = Writable bit U = Unimplemented bit, read as '0'
u = Bit is unchanged x = Bit is unknown -n/n = Value at POR and BOR/Value at all other Resets
'1' = Bit is set '0' = Bit is cleared

bit 7-6 **Unimplemented:** Read as '0'
bit 5-4 **TRISA<5:4>:** PORTA Tri-State Control bit
 1 = PORTA pin configured as an input (tri-stated)
 0 = PORTA pin configured as an output
bit 3 **Unimplemented:** Read as '1'
bit 2-0 **TRISA<2:0>:** PORTA Tri-State Control bit
 1 = PORTA pin configured as an input (tri-stated)
 0 = PORTA pin configured as an output

REGISTER 11-4: LATA: PORTA DATA LATCH REGISTER

U-0	U-0	R/W-x/u	R/W-x/u	U-0	R/W-x/u	R/W-x/u	R/W-x/u
—	—	LATA5	LATA4	—	LATA2	LATA1	LATA0
bit 7							bit 0

Legend:

R = Readable bit W = Writable bit U = Unimplemented bit, read as '0'
u = Bit is unchanged x = Bit is unknown -n/n = Value at POR and BOR/Value at all other Resets
'1' = Bit is set '0' = Bit is cleared

bit 7-6 **Unimplemented:** Read as '0'
bit 5-4 **LATA<5:4>:** RA<5:4> Output Latch Value bits⁽¹⁾
bit 3 **Unimplemented:** Read as '0'
bit 2-0 **LATA<2:0>:** RA<2:0> Output Latch Value bits⁽¹⁾

Note 1: Writes to PORTA are actually written to corresponding LATA register. Reads from PORTA register is return of actual I/O pin values.

REGISTER 11-5: ANSA: PORTA ANALOG SELECT REGISTER

U-0	U-0	R/W-1/1	R/W-1/1	U-0	R/W-1/1	R/W-1/1	R/W-1/1
—	—	ANSA5	ANSA4	—	ANSA2	ANSA1	ANSA0
bit 7							bit 0

Legend:

R = Readable bit W = Writable bit U = Unimplemented bit, read as '0'
u = Bit is unchanged x = Bit is unknown -n/n = Value at POR and BOR/Value at all other Resets
'1' = Bit is set '0' = Bit is cleared

bit 7-6 **Unimplemented:** Read as '0'
bit 5-4 **ANSA<5:4>:** Analog Select between Analog or Digital Function on pins RA4, respectively
1 = Analog input. Pin is assigned as analog input⁽¹⁾. Digital input buffer disabled.
0 = Digital I/O. Pin is assigned to port or digital special function.
bit 3 **Unimplemented:** Read as '0'
bit 2-0 **ANSA<2:0>:** Analog Select between Analog or Digital Function on pins RA<2:0>, respectively
1 = Analog input. Pin is assigned as analog input⁽¹⁾. Digital input buffer disabled.
0 = Digital I/O. Pin is assigned to port or digital special function.

Note 1: When setting a pin to an analog input, the corresponding TRIS bit must be set to Input mode in order to allow external control of the voltage on the pin.

PIC16LF1554/1559

REGISTER 11-6: WPUA: WEAK PULL-UP PORTA REGISTER^(1,2)

U-0	U-0	R/W-1/1	R/W-1/1	R/W-1/1	R/W-1/1	R/W-1/1	R/W-1/1
—	—	WPUA5	WPUA4	WPUA3	WPUA2	WPUA1	WPUA0
bit 7							bit 0

Legend:

R = Readable bit W = Writable bit U = Unimplemented bit, read as '0'
u = Bit is unchanged x = Bit is unknown -n/n = Value at POR and BOR/Value at all other Resets
'1' = Bit is set '0' = Bit is cleared

bit 7-6 **Unimplemented:** Read as '0'

bit 5-0 **WPUA<5:0>:** Weak Pull-up Register bits⁽³⁾

1 = Pull-up enabled
0 = Pull-up disabled

Note 1: Global $\overline{\text{WPUEN}}$ bit of the OPTION_REG register must be cleared for individual pull-ups to be enabled.

Note 2: The weak pull-up device is automatically disabled if the pin is configured as an output.

Note 3: For the WPUA3 bit, when MCLRE = 1, weak pull-up is internally enabled, but not reported here.

TABLE 11-3: SUMMARY OF REGISTERS ASSOCIATED WITH PORTA

Name	Bit 7	Bit 6	Bit 5	Bit 4	Bit 3	Bit 2	Bit 1	Bit 0	Register on Page
ANSELA	—	—	ANSA5	ANSA4	—	ANSA2	ANSA1	ANSA0	109
APFCON	RXDTSEL	SDOSEL	SSSEL	SDSEL	—	TXCKSEL	GRDBSEL	GRDASEL	106
LATA	—	—	LATA5	LATA4	—	LATA2	LATA1	LATA0	109
OPTION_REG	$\overline{\text{WPUEN}}$	INTEDG	TMR0CS	TMR0SE	PSA	PS<2:0>			166
PORTA	—	—	RA5	RA4	RA3	RA2	RA1	RA0	108
TRISA	—	—	TRISA5	TRISA4	— ⁽¹⁾	TRISA2	TRISA1	TRISA0	108
WPUA	—	—	WPUA5	WPUA4	WPUA3	WPUA2	WPUA1	WPUA0	110

Legend: x = unknown, u = unchanged, — = unimplemented locations read as '0'. Shaded cells are not used by PORTA.

Note 1: Unimplemented, read as '1'.

TABLE 11-4: SUMMARY OF CONFIGURATION WORD WITH PORTA

Name	Bits	Bit -/7	Bit -/6	Bit 13/5	Bit 12/4	Bit 11/3	Bit 10/2	Bit 9/1	Bit 8/0	Register on Page
CONFIG1	13:8	—	—	—	—	CLKOUTEN	BOREN<1:0>		—	53
	7:0	$\overline{\text{CP}}$	MCLRE	$\overline{\text{PWRTE}}$	WDTE<1:0>	—	FOSC<2:0>		—	

Legend: — = unimplemented location, read as '0'. Shaded cells are not used by PORTA.

11.5 PORTB Registers (PIC16LF1559 Only)

11.5.1 DATA REGISTER

PORTB is a 4-bit wide, bidirectional port. The corresponding data direction register is TRISB (Register 11-8). Setting a TRISB bit (= 1) will make the corresponding PORTB pin an input (i.e., disable the output driver). Clearing a TRISB bit (= 0) will make the corresponding PORTB pin an output (i.e., enables output driver and puts the contents of the output latch on the selected pin). Example 11-1 shows how to initialize an I/O port.

Reading the PORTB register (Register 11-7) reads the status of the pins, whereas writing to it will write to the PORT latch. All write operations are read-modify-write operations. Therefore, a write to a port implies that the port pins are read, this value is modified and then written to the PORT data latch (LATB).

11.5.2 DIRECTION CONTROL

The TRISB register (Register 11-8) controls the PORTB pin output drivers, even when they are being used as analog inputs. The user should ensure the bits in the TRISB register are maintained set when using them as analog inputs. I/O pins configured as analog input always read '0'.

11.5.3 ANALOG CONTROL

The ANSELB register (Register 11-10) is used to configure the Input mode of an I/O pin to analog. Setting the appropriate ANSELB bit high will cause all digital reads on the pin to be read as '0' and allow analog functions on the pin to operate correctly.

The state of the ANSELB bits has no effect on digital output functions. A pin with TRIS clear and ANSEL set will still operate as a digital output, but the Input mode will be analog. This can cause unexpected behavior when executing read-modify-write instructions on the affected port.

Note: The ANSELB bits default to the Analog mode after Reset. To use any pins as digital general purpose or peripheral inputs, the corresponding ANSELx bits must be initialized to '0' by user software.

11.5.4 PORTB FUNCTIONS AND OUTPUT PRIORITIES

Each PORTB pin is multiplexed with other functions. The pins, their combined functions and their output priorities are shown in Table 11-5.

When multiple outputs are enabled, the actual pin control goes to the peripheral with the highest priority.

Analog input functions, such as ADC and comparator inputs, are not shown in the priority lists. These inputs are active when the I/O pin is set for Analog mode using the ANSELx registers. Digital output functions may control the pin when it is in Analog mode with the priority shown below in Table 11-5.

TABLE 11-5: PORTB OUTPUT PRIORITY

Pin Name	Function Priority ⁽¹⁾
RB4	SDA RB4
RB5	RB5
RB6	SCL SCK RB6
RB7	TX RB7

Note 1: Priority listed from highest to lowest.

PIC16LF1554/1559

11.6 Register Definitions: PORTB

REGISTER 11-7: PORTB: PORTB REGISTER

R/W-x/x	R/W-x/x	R/W-x/x	R/W-x/x	U-0	U-0	U-0	U-0
RB7	RB6	RB5	RB4	—	—	—	—
bit 7							bit 0

Legend:

R = Readable bit W = Writable bit U = Unimplemented bit, read as '0'
u = Bit is unchanged x = Bit is unknown -n/n = Value at POR and BOR/Value at all other Resets
'1' = Bit is set '0' = Bit is cleared

bit 7-4 **RB<7:4>**: PORTB I/O Value bits⁽¹⁾
 1 = Port pin is $\geq V_{IH}$
 0 = Port pin is $\leq V_{IL}$

bit 3-0 **Unimplemented**: Read as '0'

Note 1: Writes to PORTB are actually written to corresponding LATB register. Reads from PORTB register is return of actual I/O pin values.

REGISTER 11-8: TRISB: PORTB TRI-STATE REGISTER

R/W-1/1	R/W-1/1	R/W-1/1	R/W-1/1	U-0	U-0	U-0	U-0
TRISB7	TRISB6	TRISB5	TRISB4	—	—	—	—
bit 7							bit 0

Legend:

R = Readable bit W = Writable bit U = Unimplemented bit, read as '0'
u = Bit is unchanged x = Bit is unknown -n/n = Value at POR and BOR/Value at all other Resets
'1' = Bit is set '0' = Bit is cleared

bit 7-4 **TRISB<7:4>**: PORTB Tri-State Control bits
 1 = PORTB pin configured as an input (tri-stated)
 0 = PORTB pin configured as an output

bit 3-0 **Unimplemented**: Read as '0'

REGISTER 11-9: LATB: PORTB DATA LATCH REGISTER

R/W-x/u	R/W-x/u	R/W-x/u	R/W-x/u	U-0	U-0	U-0	U-0
LATB7	LATB6	LATB5	LATB4	—	—	—	—
bit 7							bit 0

Legend:

R = Readable bit W = Writable bit U = Unimplemented bit, read as '0'
 u = Bit is unchanged x = Bit is unknown -n/n = Value at POR and BOR/Value at all other Resets
 '1' = Bit is set '0' = Bit is cleared

bit 7-4 **LATB<7:4>**: RB<7:4> Output Latch Value bits⁽¹⁾

bit 3-0 **Unimplemented**: Read as '0'

Note 1: Writes to PORTB are actually written to corresponding LATB register. Reads from PORTB register is return of actual I/O pin values.

REGISTER 11-10: ANSELB: PORTB ANALOG SELECT REGISTER

R/W-1/1	R/W-1/1	R/W-1/1	R/W-1/1	U-0	U-0	U-0	U-0
ANSB7	ANSB6	ANSB5	ANSB4	—	—	—	—
bit 7							bit 0

Legend:

R = Readable bit W = Writable bit U = Unimplemented bit, read as '0'
 u = Bit is unchanged x = Bit is unknown -n/n = Value at POR and BOR/Value at all other Resets
 '1' = Bit is set '0' = Bit is cleared

bit 7-4 **ANSB<7:4>**: Analog Select between Analog or Digital Function on pins RB<5:4>, respectively

1 = Analog input. Pin is assigned as analog input⁽¹⁾. Digital input buffer disabled.

0 = Digital I/O. Pin is assigned to port or digital special function.

bit 3-0 **Unimplemented**: Read as '0'

Note 1: When setting a pin to an analog input, the corresponding TRIS bit must be set to Input mode in order to allow external control of the voltage on the pin.

PIC16LF1554/1559

REGISTER 11-11: WPUB: WEAK PULL-UP PORTB REGISTER^(1,2)

R/W-1/1	R/W-1/1	R/W-1/1	R/W-1/1	U-0	U-0	U-0	U-0
WPUB7	WPUB6	WPUB5	WPUB4	—	—	—	—
bit 7							bit 0

Legend:

R = Readable bit W = Writable bit U = Unimplemented bit, read as '0'
u = Bit is unchanged x = Bit is unknown -n/n = Value at POR and BOR/Value at all other Resets
'1' = Bit is set '0' = Bit is cleared

bit 7-4 **WPUB<7:4>**: Weak Pull-up Register bits
 1 = Pull-up enabled
 0 = Pull-up disabled

bit 3-0 **Unimplemented**: Read as '0'

- Note 1:** Global $\overline{\text{WPUEN}}$ bit of the OPTION_REG register must be cleared for individual pull-ups to be enabled.
Note 2: The weak pull-up device is automatically disabled if the pin is configured as an output.

TABLE 11-6: SUMMARY OF REGISTERS ASSOCIATED WITH PORTB⁽¹⁾

Name	Bit 7	Bit 6	Bit 5	Bit 4	Bit 3	Bit 2	Bit 1	Bit 0	Register on Page
ANSELB	ANSB7	ANSB6	ANSB5	ANSB4	—	—	—	—	113
APFCON	RXDTSEL	SDOSEL	SSSEL	SDSEL	—	TXCKSEL	GRDBSEL	GRDASEL	106
LATB	LATB7	LATB6	LATB5	LATB4	—	—	—	—	113
OPTION_REG	$\overline{\text{WPUEN}}$	INTEDG	TMR0CS	TMR0SE	PSA	PS<2:0>			166
PORTB	RB7	RB6	RB5	RB4	—	—	—	—	112
TRISB	TRISB7	TRISB6	TRISB5	TRISB4	—	—	—	—	112
WPUB	WPUB7	WPUB6	WPUB5	WPUB4	—	—	—	—	114

Legend: x = unknown, u = unchanged, — = unimplemented locations read as '0'. Shaded cells are not used by PORTB.

Note 1: PIC16LF1559 only.

TABLE 11-7: SUMMARY OF CONFIGURATION WORD WITH PORTB

Name	Bits	Bit -/7	Bit -/6	Bit 13/5	Bit 12/4	Bit 11/3	Bit 10/2	Bit 9/1	Bit 8/0	Register on Page
CONFIG1	13:8	—	—	—	—	$\overline{\text{CLKOUTEN}}$	BOREN<1:0>		—	53
	7:0	$\overline{\text{CP}}$	MCLRE	$\overline{\text{PWRTE}}$	WDTE<1:0>		—	FOSC<1:0>		

Legend: — = unimplemented location, read as '0'. Shaded cells are not used by PORTB.

11.7 PORTC Registers

11.7.1 DATA REGISTER

PORTC is a 8-bit wide, bidirectional port. The corresponding data direction register is TRISC (Register 11-13). Setting a TRISC bit (= 1) will make the corresponding PORTC pin an input (i.e., disable the output driver). Clearing a TRISC bit (= 0) will make the corresponding PORTC pin an output (i.e., enable the output driver and put the contents of the output latch on the selected pin). Example 11-1 shows how to initialize an I/O port.

Reading the PORTC register (Register 11-12) reads the status of the pins, whereas writing to it will write to the PORT latch. All write operations are read-modify-write operations. Therefore, a write to a port implies that the port pins are read, this value is modified and then written to the PORT data latch (LATC).

11.7.2 DIRECTION CONTROL

The TRISC register (Register 11-13) controls the PORTC pin output drivers, even when they are being used as analog inputs. The user should ensure the bits in the TRISC register are maintained set when using them as analog inputs. I/O pins configured as analog input always read '0'.

11.7.3 ANALOG CONTROL

The ANSEL register (Register 11-15) is used to configure the Input mode of an I/O pin to analog. Setting the appropriate ANSEL bit high will cause all digital reads on the pin to be read as '0' and allow analog functions on the pin to operate correctly.

The state of the ANSEL bits has no effect on digital output functions. A pin with TRIS clear and ANSEL set will still operate as a digital output, but the Input mode will be analog. This can cause unexpected behavior when executing read-modify-write instructions on the affected port.

Note: The ANSEL bits default to the Analog mode after Reset. To use any pins as digital general purpose or peripheral inputs, the corresponding ANSELx bits must be initialized to '0' by user software.

11.7.4 PORTC FUNCTIONS AND OUTPUT PRIORITIES

Each PORTC pin is multiplexed with other functions. The pins, their combined functions and their output priorities are shown in Table 11-8.

When multiple outputs are enabled, the actual pin control goes to the peripheral with the highest priority.

Analog input and some digital input functions are not included in the output priority list. These input functions can remain active when the pin is configured as an output. Certain digital input functions override other port functions and are included in the output priority list.

TABLE 11-8: PORTC OUTPUT PRIORITY

Pin Name	Function Priority ⁽¹⁾
RC0	RC0
RC1	RC1
RC2	PWM1 RC2
RC4	RC4
RC5	RC5
RC6	RC6
RC7	SDO RC7

Note 1: Priority listed from highest to lowest.

PIC16LF1554/1559

11.8 Register Definitions: PORTC

REGISTER 11-12: PORTC: PORTC REGISTER

R/W-x/u	R/W-x/u	R/W-x/u	R/W-x/u	R/W-x/u	R/W-x/u	R/W-x/u	R/W-x/u
RC7 ⁽¹⁾	RC6 ⁽¹⁾	RC5	RC4	RC3	RC2	RC1	RC0
bit 7							bit 0

Legend:

R = Readable bit W = Writable bit U = Unimplemented bit, read as '0'
u = Bit is unchanged x = Bit is unknown -n/n = Value at POR and BOR/Value at all other Resets
'1' = Bit is set '0' = Bit is cleared

bit 7-0 **RC<7:0>**: PORTC General Purpose I/O Pin bits
1 = Port pin is $\geq V_{IH}$
0 = Port pin is $\leq V_{IL}$

Note 1: Functions not available on PIC16LF1554.

REGISTER 11-13: TRISC: PORTC TRI-STATE REGISTER

R/W-1/1	R/W-1/1	R/W-1/1	R/W-1/1	R/W-1/1	R/W-1/1	R/W-1/1	R/W-1/1
TRISC7 ⁽¹⁾	TRISC6 ⁽¹⁾	TRISC5	TRISC4	TRISC3	TRISC2	TRISC1	TRISC0
bit 7							bit 0

Legend:

R = Readable bit W = Writable bit U = Unimplemented bit, read as '0'
u = Bit is unchanged x = Bit is unknown -n/n = Value at POR and BOR/Value at all other Resets
'1' = Bit is set '0' = Bit is cleared

bit 7-0 **TRISC<7:0>**: PORTC Tri-State Control bits
1 = PORTC pin configured as an input (tri-stated)
0 = PORTC pin configured as an output

Note 1: Functions not available on PIC16LF1554.

REGISTER 11-14: LATC: PORTC DATA LATCH REGISTER

R/W-x/u	R/W-x/u	R/W-x/u	R/W-x/u	R/W-x/u	R/W-x/u	R/W-x/u	R/W-x/u
LATC7 ⁽¹⁾	LATC6 ⁽¹⁾	LATC5	LATC4	LATC3	LATC2	LATC1	LATC0
bit 7							bit 0

Legend:

R = Readable bit W = Writable bit U = Unimplemented bit, read as '0'
u = Bit is unchanged x = Bit is unknown -n/n = Value at POR and BOR/Value at all other Resets
'1' = Bit is set '0' = Bit is cleared

bit 7-0 **LATC<7:0>**: PORTC Output Latch Value bits⁽²⁾

Note 1: Functions not available on PIC16LF1554.

2: Writes to PORTC are actually written to corresponding LATC register. Reads from PORTC register is return of actual I/O pin values.

REGISTER 11-15: ANSEL: PORTC ANALOG SELECT REGISTER

R/W-1/1	R/W-1/1	R/W-1/1	R/W-1/1	R/W-1/1	R/W-1/1	R/W-1/1	R/W-1/1
ANSC7 ⁽¹⁾	ANSC6 ⁽¹⁾	ANSC5	ANSC4	ANSC3	ANSC2	ANSC1	ANSC0
bit 7							bit 0

Legend:

R = Readable bit W = Writable bit U = Unimplemented bit, read as '0'
u = Bit is unchanged x = Bit is unknown -n/n = Value at POR and BOR/Value at all other Resets
'1' = Bit is set '0' = Bit is cleared

bit 7-0 **ANSC<7:0>**: Analog Select between Analog or Digital Function on pins RC<7:0>, respectively
1 = Analog input. Pin is assigned as analog input⁽²⁾. Digital input buffer disabled.
0 = Digital I/O. Pin is assigned to port or digital special function.

Note 1: Functions not available on PIC16LF1554.

2: When setting a pin to an analog input, the corresponding TRIS bit must be set to Input mode in order to allow external control of the voltage on the pin.

TABLE 11-9: SUMMARY OF REGISTERS ASSOCIATED WITH PORTC

Name	Bit 7	Bit 6	Bit 5	Bit 4	Bit 3	Bit 2	Bit 1	Bit 0	Register on Page
ANSEL	ANSC7 ⁽¹⁾	ANSC6 ⁽¹⁾	ANSC5	ANSC4	ANSC3	ANSC2	ANSC1	ANSC0	117
LATC	LATC7 ⁽¹⁾	LATC6 ⁽¹⁾	LATC5	LATC4	LATC3	LATC2	LATC1	LATC0	117
PORTC	RC7 ⁽¹⁾	RC6 ⁽¹⁾	RC5	RC4	RC3	RC2	RC1	RC0	116
TRISC	TRISC7 ⁽¹⁾	TRISC6 ⁽¹⁾	TRISC5	TRISC4	TRISC3	TRISC2	TRISC1	TRISC0	116

Legend: x = unknown, u = unchanged, - = unimplemented locations read as '0'. Shaded cells are not used by PORTC.

Note 1: Functions not available on PIC16LF1554.

12.0 INTERRUPT-ON-CHANGE

The PORTA and PORTB pins can be configured to operate as Interrupt-On-Change (IOC) pins. An interrupt can be generated by detecting a signal that has either a rising edge or a falling edge. Any individual port pin, or combination of port pins, can be configured to generate an interrupt. The interrupt-on-change module has the following features:

- Interrupt-on-Change enable (Master Switch)
- Individual pin configuration
- Rising and falling edge detection
- Individual pin interrupt flags

Figure 12-1 is a block diagram of the IOC module.

12.1 Enabling the Module

To allow individual port pins to generate an interrupt, the IOCIE bit of the INTCON register must be set. If the IOCIE bit is disabled, the edge detection on the pin will still occur, but an interrupt will not be generated.

12.2 Individual Pin Configuration

For each port pin, a rising edge detector and a falling edge detector are present. To enable a pin to detect a rising edge, the associated bit of the IOCxP register is set. To enable a pin to detect a falling edge, the associated bit of the IOCxN register is set.

A pin can be configured to detect rising and falling edges simultaneously by setting both associated bits of the IOCxP and IOCxN registers, respectively.

12.3 Interrupt Flags

The IOCAF_x and IOCBF_x bits located in the IOCAF and IOCBF registers, respectively, are status flags that correspond to the interrupt-on-change pins of the associated port. If an expected edge is detected on an appropriately enabled pin, then the status flag for that pin will be set, and an interrupt will be generated if the IOCIE bit is set. The IOCIF bit of the INTCON register reflects the status of all IOCAF_x and IOCBF_x bits.

12.4 Clearing Interrupt Flags

The individual status flags, (IOCAF_x and IOCBF_x bits), can be cleared by resetting them to zero. If another edge is detected during this clearing operation, the associated status flag will be set at the end of the sequence, regardless of the value actually being written.

In order to ensure that no detected edge is lost while clearing flags, only AND operations masking out known changed bits should be performed. The following sequence is an example of what should be performed.

EXAMPLE 12-1: CLEARING INTERRUPT FLAGS (PORTA EXAMPLE)

```
MOVLW  0xff
XORWF  IOCAF, W
ANDWF  IOCAF, F
```

12.5 Operation in Sleep

The interrupt-on-change interrupt sequence will wake the device from Sleep mode, if the IOCIE bit is set.

If an edge is detected while in Sleep mode, the IOCxF register will be updated prior to the first instruction executed out of Sleep.

FIGURE 12-1: INTERRUPT-ON-CHANGE BLOCK DIAGRAM (PORTA EXAMPLE)

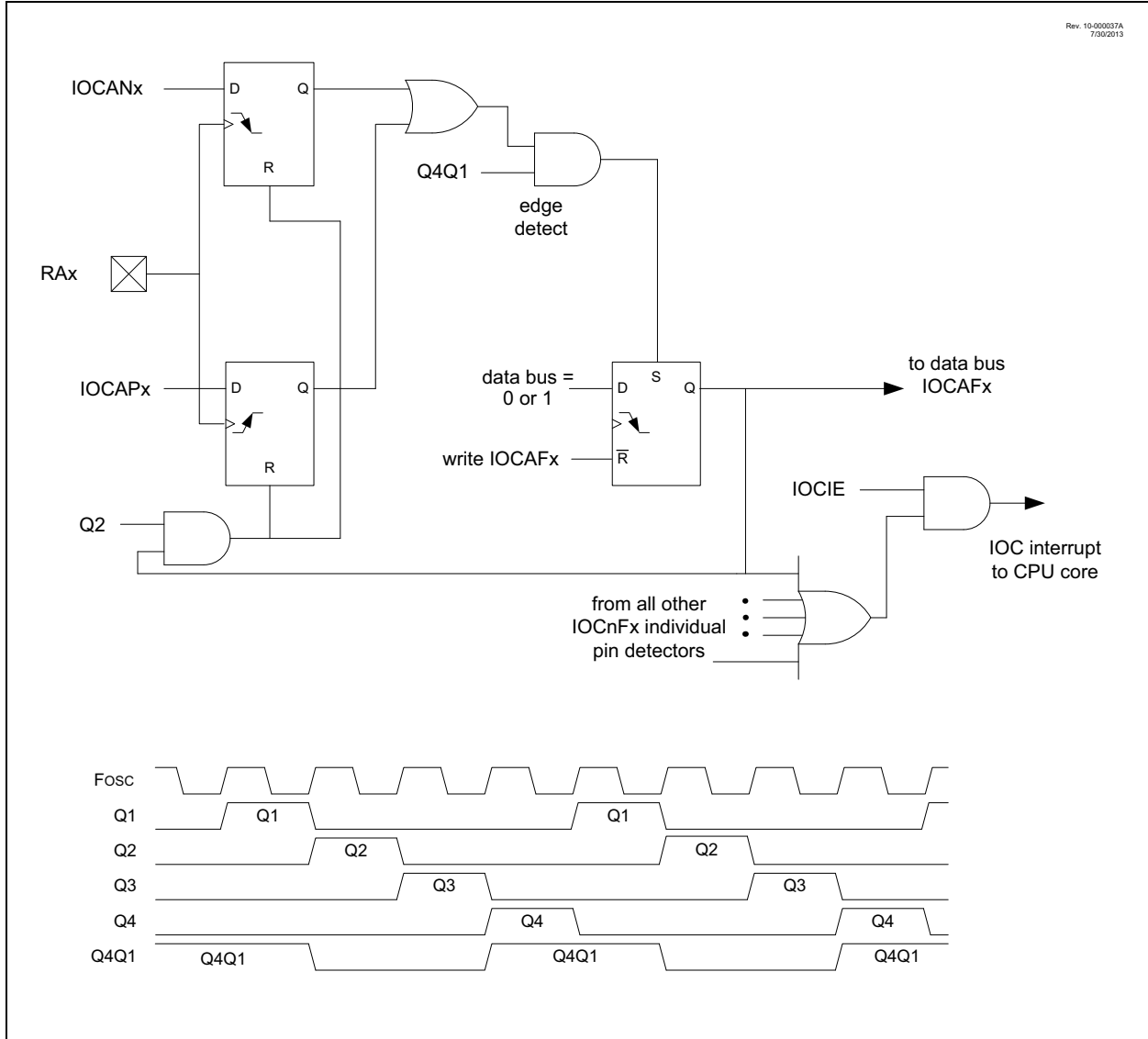

PIC16LF1554/1559

12.6 Register Definitions: Interrupt-on-Change Control

REGISTER 12-1: IOCAP: INTERRUPT-ON-CHANGE PORTA POSITIVE EDGE REGISTER

U-0	U-0	R/W-0/0	R/W-0/0	R/W-0/0	R/W-0/0	R/W-0/0	R/W-0/0
—	—	IOCAP5	IOCAP4	IOCAP3	IOCAP2	IOCAP1	IOCAP0
bit 7							bit 0

Legend:

R = Readable bit W = Writable bit U = Unimplemented bit, read as '0'
u = Bit is unchanged x = Bit is unknown -n/n = Value at POR and BOR/Value at all other Resets
'1' = Bit is set '0' = Bit is cleared

bit 7-6 **Unimplemented:** Read as '0'

bit 5-0 **IOCAP<5:0>:** Interrupt-on-Change PORTA Positive Edge Enable bits
1 = Interrupt-on-Change enabled on the pin for a positive going edge. IOCAF_x bit and IOCIF flag will be set upon detecting an edge.
0 = Interrupt-on-Change disabled for the associated pin.

REGISTER 12-2: IOCAN: INTERRUPT-ON-CHANGE PORTA NEGATIVE EDGE REGISTER

U-0	U-0	R/W-0/0	R/W-0/0	R/W-0/0	R/W-0/0	R/W-0/0	R/W-0/0
—	—	IOCAN5	IOCAN4	IOCAN3	IOCAN2	IOCAN1	IOCAN0
bit 7							bit 0

Legend:

R = Readable bit W = Writable bit U = Unimplemented bit, read as '0'
u = Bit is unchanged x = Bit is unknown -n/n = Value at POR and BOR/Value at all other Resets
'1' = Bit is set '0' = Bit is cleared

bit 7-6 **Unimplemented:** Read as '0'

bit 5-0 **IOCAN<5:0>:** Interrupt-on-Change PORTA Negative Edge Enable bits
1 = Interrupt-on-Change enabled on the pin for a negative going edge. IOCAF_x bit and IOCIF flag will be set upon detecting an edge.
0 = Interrupt-on-Change disabled for the associated pin.

REGISTER 12-3: IOCAF: INTERRUPT-ON-CHANGE PORTA FLAG REGISTER

U-0	U-0	R/W/HS-0/0	R/W/HS-0/0	R/W/HS-0/0	R/W/HS-0/0	R/W/HS-0/0	R/W/HS-0/0
—	—	IOCAF5	IOCAF4	IOCAF3	IOCAF2	IOCAF1	IOCAF0
bit 7							bit 0

Legend:

R = Readable bit W = Writable bit U = Unimplemented bit, read as '0'
u = Bit is unchanged x = Bit is unknown -n/n = Value at POR and BOR/Value at all other Resets
'1' = Bit is set '0' = Bit is cleared HS - Bit is set in hardware

bit 7-6 **Unimplemented:** Read as '0'

bit 5-0 **IOCAF<5:0>:** Interrupt-on-Change PORTA Flag bits
1 = An enabled change was detected on the associated pin.
Set when IOCAP_x = 1 and a rising edge was detected on RAX, or when IOCAN_x = 1 and a falling edge was detected on RAX.
0 = No change was detected, or the user cleared the detected change.

REGISTER 12-4: IOCBP: INTERRUPT-ON-CHANGE PORTB POSITIVE EDGE REGISTER

R/W-0/0	R/W-0/0	R/W-0/0	R/W-0/0	U-0	U-0	U-0	U-0
IOCBP7	IOCBP6	IOCBP5	IOCBP4	—	—	—	—
bit 7							bit 0

Legend:

R = Readable bit W = Writable bit U = Unimplemented bit, read as '0'
u = Bit is unchanged x = Bit is unknown -n/n = Value at POR and BOR/Value at all other Resets
'1' = Bit is set '0' = Bit is cleared

bit 7-4 **IOCBP<7:4>:** Interrupt-on-Change PORTB Positive Edge Enable bits
1 = Interrupt-on-Change enabled on the pin for a positive going edge. IOCBFx bit and IOCIF flag will be set upon detecting an edge.
0 = Interrupt-on-Change disabled for the associated pin.

bit 3-0 **Unimplemented:** Read as '0'

REGISTER 12-5: IOCBN: INTERRUPT-ON-CHANGE PORTB NEGATIVE EDGE REGISTER

R/W-0/0	R/W-0/0	R/W-0/0	R/W-0/0	U-0	U-0	U-0	U-0
IOCBN7	IOCBN6	IOCBN5	IOCBN4	—	—	—	—
bit 7							bit 0

Legend:

R = Readable bit W = Writable bit U = Unimplemented bit, read as '0'
u = Bit is unchanged x = Bit is unknown -n/n = Value at POR and BOR/Value at all other Resets
'1' = Bit is set '0' = Bit is cleared

bit 7-4 **IOCBN<7:4>:** Interrupt-on-Change PORTB Negative Edge Enable bits
1 = Interrupt-on-Change enabled on the pin for a negative going edge. IOCBFx bit and IOCIF flag will be set upon detecting an edge.
0 = Interrupt-on-Change disabled for the associated pin.

bit 3-0 **Unimplemented:** Read as '0'

REGISTER 12-6: IOCBF: INTERRUPT-ON-CHANGE PORTB FLAG REGISTER

R/W/HS-0/0	R/W/HS-0/0	R/W/HS-0/0	R/W/HS-0/0	U-0	U-0	U-0	U-0
IOCBF7	IOCBF6	IOCBF5	IOCBF4	—	—	—	—
bit 7							bit 0

Legend:

R = Readable bit W = Writable bit U = Unimplemented bit, read as '0'
u = Bit is unchanged x = Bit is unknown -n/n = Value at POR and BOR/Value at all other Resets
'1' = Bit is set '0' = Bit is cleared HS - Bit is set in hardware

bit 7-4 **IOCBF<7:4>:** Interrupt-on-Change PORTB Flag bits
1 = An enabled change was detected on the associated pin.
Set when IOCBPx = 1 and a rising edge was detected on RBx, or when IOCBNx = 1 and a falling edge was detected on RBx.
0 = No change was detected, or the user cleared the detected change.

bit 3-0 **Unimplemented:** Read as '0'

PIC16LF1554/1559

TABLE 12-1: SUMMARY OF REGISTERS ASSOCIATED WITH INTERRUPT-ON-CHANGE

Name	Bit 7	Bit 6	Bit 5	Bit 4	Bit 3	Bit 2	Bit 1	Bit 0	Register on Page
ANSELA	—	—	ANSA5	ANSA4	—	ANSA2	ANSA1	ANSA0	109
INTCON	GIE	PEIE	TMR0IE	INTE	IOCIE	TMR0IF	INTF	IOCIF	77
IOCAF	—	—	IOCAF5	IOCAF4	IOCAF3	IOCAF2	IOCAF1	IOCAF0	120
IOCAN	—	—	IOCAN5	IOCAN4	IOCAN3	IOCAN2	IOCAN1	IOCAN0	120
IOCAP	—	—	IOCAP5	IOCAP4	IOCAP3	IOCAP2	IOCAP1	IOCAP0	120
IOCBF	IOCBF7	IOCBF6	IOCBF5	IOCBF4	—	—	—	—	121
IOCBN	IOCBN7	IOCBN6	IOCBN5	IOCBN4	—	—	—	—	121
IOCBP	IOCBP7	IOCBP6	IOCBP5	IOCBP4	—	—	—	—	121
TRISA	—	—	TRISA5	TRISA4	— ⁽¹⁾	TRISA2	TRISA1	TRISA0	108
TRISB	TRISB7	TRISB6	TRISB5	TRISB4	—	—	—	—	112

Legend: — = unimplemented location, read as '0'. Shaded cells are not used by interrupt-on-change.

Note 1: Unimplemented, read as '1'.

13.0 FIXED VOLTAGE REFERENCE (FVR)

The Fixed Voltage Reference, or FVR, is a stable voltage reference, independent of V_{DD} , with 1.024V and 2.048V selectable output levels. The output of the FVR can be configured as the FVR input channel on the ADC.

The FVR can be enabled by setting the FVREN bit of the FVRCON register.

13.1 Independent Gain Amplifier

The output of the FVR supplied to the ADC is routed through a programmable gain amplifier. Each amplifier can be programmed for a gain of 1x or 2x, to produce the two possible voltage levels.

The ADFVR<1:0> bits of the FVRCON register are used to enable and configure the gain amplifier settings for the reference supplied to the ADC module. Reference [Section 15.0 “Analog-to-Digital Converter \(ADC\) Module”](#) for additional information.

13.2 FVR Stabilization Period

When the Fixed Voltage Reference module is enabled, it requires time for the reference and amplifier circuits to stabilize. Once the circuits stabilize and are ready for use, the FVRRDY bit of the FVRCON register will be set. See [Section 25.0 “Electrical Specifications”](#) for the minimum delay requirement.

FIGURE 13-1: VOLTAGE REFERENCE BLOCK DIAGRAM

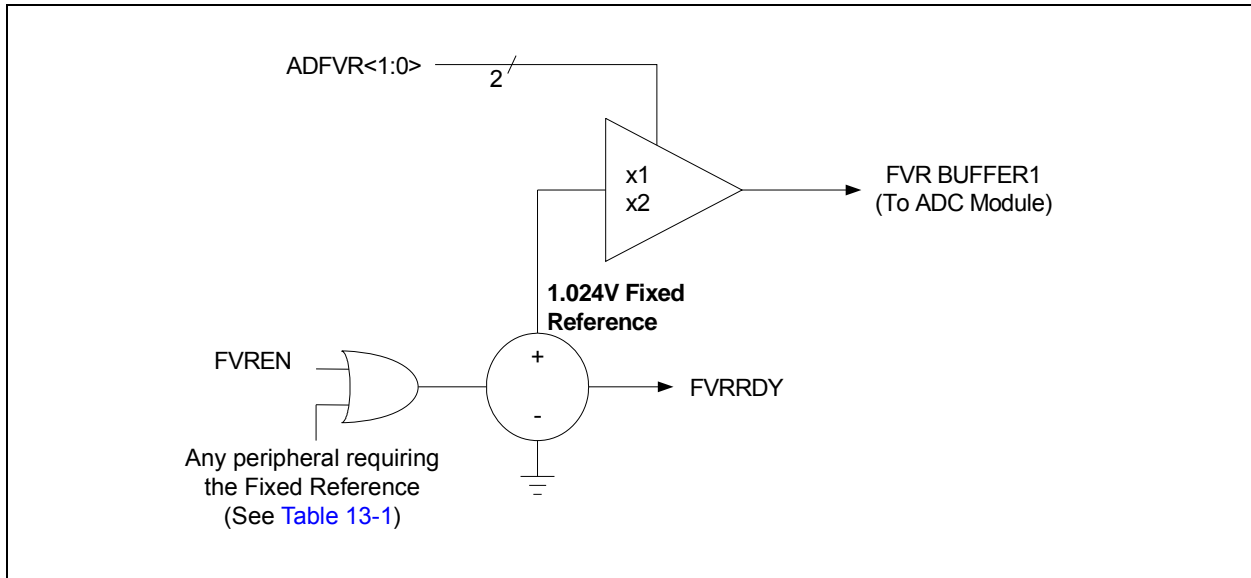

TABLE 13-1: PERIPHERALS REQUIRING THE FIXED VOLTAGE REFERENCE (FVR)

Peripheral	Conditions	Description
HFINTOSC	FOSC<1:0> = 00 and IRCF<3:0> = 000x	INTOSC is active and device is not in Sleep.
BOR	BOREN<1:0> = 11	BOR always enabled.
	BOREN<1:0> = 10 and BORFS = 1	BOR disabled in Sleep mode, BOR Fast Start enabled.
	BOREN<1:0> = 01 and BORFS = 1	BOR under software control, BOR Fast Start enabled.

PIC16LF1554/1559

13.3 Register Definitions: FVR Control

REGISTER 13-1: FVRCON: FIXED VOLTAGE REFERENCE CONTROL REGISTER

R/W-0/0	R-q/q	R/W-0/0	R/W-0/0	U-0	U-0	R/W-0/0	R/W-0/0
FVREN	FVRRDY	TSEN	TSRNG	—	—	ADFVR<1:0>	
bit 7							bit 0

Legend:

R = Readable bit	W = Writable bit	U = Unimplemented bit, read as '0'
u = Bit is unchanged	x = Bit is unknown	-n/n = Value at POR and BOR/Value at all other Resets
'1' = Bit is set	'0' = Bit is cleared	q = Value depends on condition

- bit 7 **FVREN:** Fixed Voltage Reference Enable bit
1 = Fixed Voltage Reference is enabled
0 = Fixed Voltage Reference is disabled
- bit 6 **FVRRDY:** Fixed Voltage Reference Ready Flag bit
1 = Fixed Voltage Reference output is ready for use
0 = Fixed Voltage Reference output is not ready or not enabled
- bit 5 **TSEN:** Temperature Indicator Enable bit⁽¹⁾
1 = Temperature Indicator is enabled
0 = Temperature Indicator is disabled
- bit 4 **TSRNG:** Temperature Indicator Range Selection bit⁽¹⁾
1 = VOUT = VDD - 4VT (High Range)
0 = VOUT = VDD - 2VT (Low Range)
- bit 3-2 **Unimplemented:** Read as '0'
- bit 1-0 **ADFVR<1:0>:** ADC Fixed Voltage Reference Selection bit
11 = ADC Fixed Voltage Reference Peripheral output is off
10 = ADC Fixed Voltage Reference Peripheral output is 2x (2.048V)⁽²⁾
01 = ADC Fixed Voltage Reference Peripheral output is 1x (1.024V)
00 = ADC Fixed Voltage Reference Peripheral output is off

- Note 1:** See [Section 14.0 “Temperature Indicator Module”](#) for additional information.
Note 2: Fixed Voltage Reference output cannot exceed VDD.

TABLE 13-2: SUMMARY OF REGISTERS ASSOCIATED WITH THE FIXED VOLTAGE REFERENCE

Name	Bit 7	Bit 6	Bit 5	Bit 4	Bit 3	Bit 2	Bit 1	Bit 0	Register on page
FVRCON	FVREN	FVRRDY	TSEN	TSRNG	—	—	ADFVR<1:0>		124

Legend: Shaded cells are unused by the Fixed Voltage Reference module.

14.0 TEMPERATURE INDICATOR MODULE

This family of devices is equipped with a temperature circuit designed to measure the operating temperature of the silicon die. The circuit's range of operating temperature falls between -40°C and $+85^{\circ}\text{C}$. The output is a voltage that is proportional to the device temperature. The output of the temperature indicator is internally connected to the device ADC.

The circuit may be used as a temperature threshold detector or a more accurate temperature indicator, depending on the level of calibration performed. A one-point calibration allows the circuit to indicate a temperature closely surrounding that point. A two-point calibration allows the circuit to sense the entire range of temperature more accurately. Reference Application Note AN1333, "Use and Calibration of the Internal Temperature Indicator" (DS01333) for more details regarding the calibration process.

14.1 Circuit Operation

Figure 14-1 shows a simplified block diagram of the temperature circuit. The proportional voltage output is achieved by measuring the forward voltage drop across multiple silicon junctions.

Equation 14-1 describes the output characteristics of the temperature indicator.

EQUATION 14-1: V_{OUT} RANGES

High Range: $V_{OUT} = V_{DD} - 4V_T$

Low Range: $V_{OUT} = V_{DD} - 2V_T$

The temperature sense circuit is integrated with the Fixed Voltage Reference (FVR) module. See Section 13.0 "Fixed Voltage Reference (FVR)" for more information.

The circuit is enabled by setting the TSEN bit of the FVRCON register. When disabled, the circuit draws no current.

The circuit operates in either high or low range. The high range, selected by setting the TSRNG bit of the FVRCON register, provides a wider output voltage. This provides more resolution over the temperature range, but may be less consistent from part to part. This range requires a higher bias voltage to operate and thus, a higher V_{DD} is needed.

The low range is selected by clearing the TSRNG bit of the FVRCON register. The low range generates a lower voltage drop and thus, a lower bias voltage is needed to operate the circuit. The low range is provided for low voltage operation.

FIGURE 14-1: TEMPERATURE CIRCUIT DIAGRAM

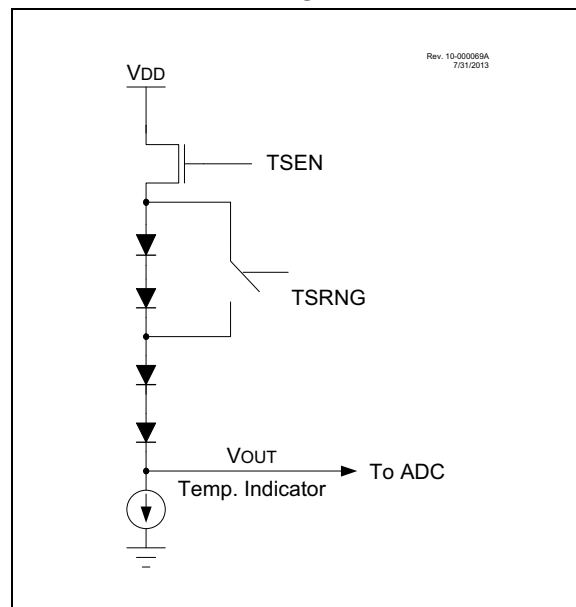

14.2 Minimum Operating V_{DD}

When the temperature circuit is operated in low range, the device may be operated at any operating voltage that is within specifications.

When the temperature circuit is operated in high range, the device operating voltage, V_{DD} , must be high enough to ensure that the temperature circuit is correctly biased.

Table 14-1 shows the recommended minimum V_{DD} vs. range setting.

TABLE 14-1: RECOMMENDED V_{DD} vs. RANGE

Min. V_{DD} , TSRNG = 1	Min. V_{DD} , TSRNG = 0
3.6V	1.8V

14.3 Temperature Output

The output of the circuit is measured using the internal Analog-to-Digital Converter. A channel is reserved for the temperature circuit output. Refer to Section 15.0 "Analog-to-Digital Converter (ADC) Module" for detailed information.

PIC16LF1554/1559

14.4 ADC Acquisition Time

To ensure accurate temperature measurements, the user must wait at least 200 μ s after the ADC input multiplexer is connected to the temperature indicator output before the conversion is performed. In addition, the user must wait 200 μ s between sequential conversions of the temperature indicator output.

TABLE 14-2: SUMMARY OF REGISTERS ASSOCIATED WITH THE TEMPERATURE INDICATOR

Name	Bit 7	Bit 6	Bit 5	Bit 4	Bit 3	Bit 2	Bit 1	Bit 0	Register on page
FVRCON	FVREN	FVRRDY	TSEN	TSRNG	—	—	ADFVR<1:0>		118

Legend: Shaded cells are unused by the temperature indicator module.

15.0 ANALOG-TO-DIGITAL CONVERTER (ADC) MODULE

The Analog-to-Digital Converter (ADC) allows conversion of an analog input signal to a 10-bit binary representation of that signal. This device uses analog inputs, which are multiplexed into a single sample and hold circuit. The output of the sample and hold is connected to the input of the converter. The converter generates a 10-bit binary result via successive approximation and stores the conversion result into the ADC result registers (ADxRESxH:ADxRESxL register pair).

The ADC voltage reference is software selectable to be either internally generated or externally supplied.

The ADC can generate an interrupt upon completion of a conversion. This interrupt can be used to wake-up the device from Sleep.

The PIC16LF1554/1559 has two ADCs, which can operate together or separately. Both ADCs can generate an interrupt upon completion of a conversion. This interrupt can be used to wake up the device from Sleep. [Figure 15-1](#) shows the block diagram of the two ADCs.

FIGURE 15-1: ADC SIMPLIFIED BLOCK DIAGRAM

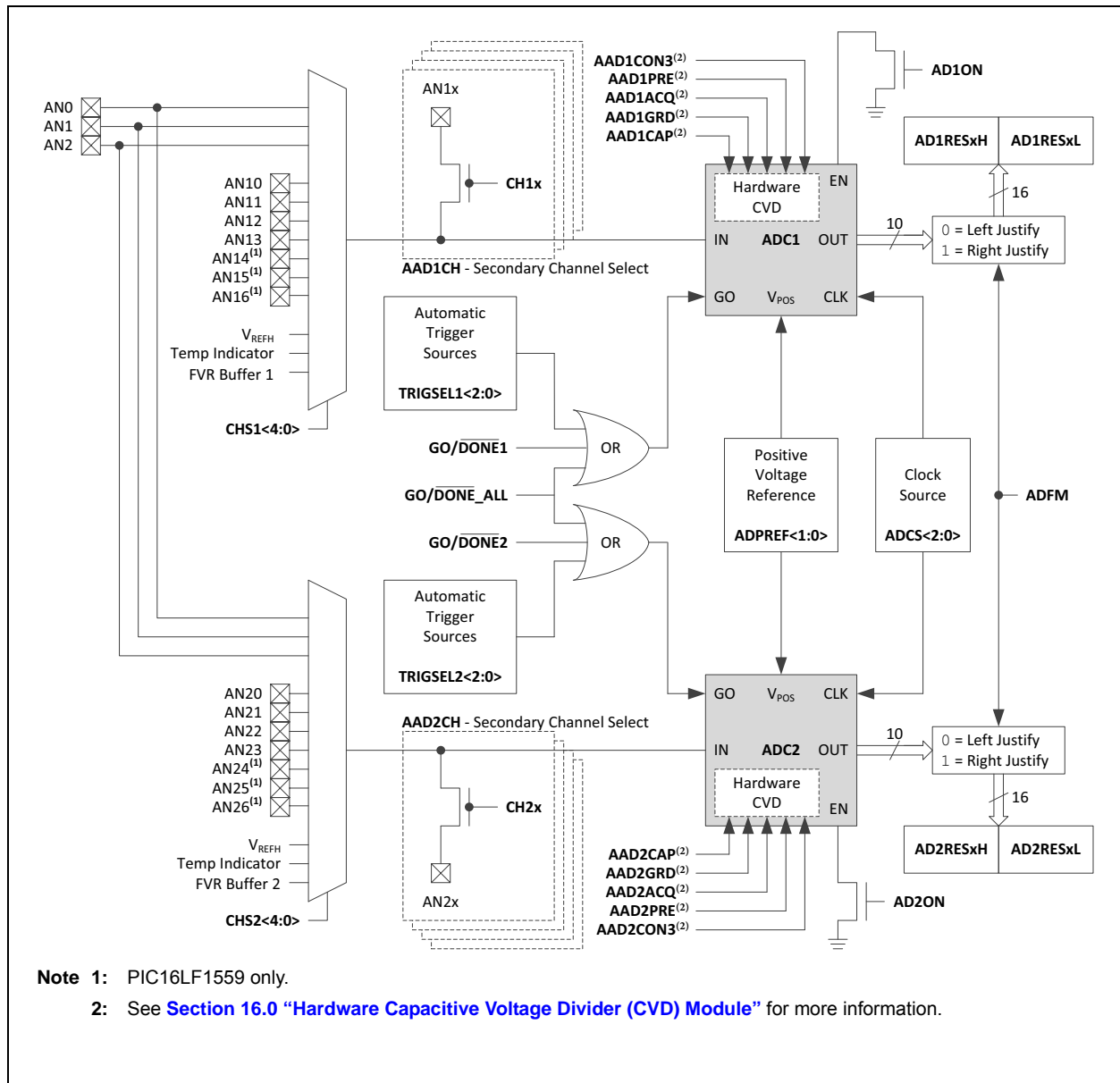

PIC16LF1554/1559

15.1 ADC Configuration

When configuring and using the ADC the following functions must be considered:

- Port configuration
- Channel selection
- ADC voltage reference selection
- ADC conversion clock source
- Interrupt control
- Result formatting

15.1.1 PORT CONFIGURATION

The ADC can be used to convert both analog and digital signals. When converting analog signals, the I/O pin should be configured for analog by setting the associated TRISx and ANSELx bits. Refer to [Section 11.0 “I/O Ports”](#) for more information.

Note: Analog voltages on any pin that is defined as a digital input may cause the input buffer to conduct excess current.

15.1.2 CHANNEL SELECTION

There are 11 channel selections available for PIC16LF1554 and 17 for PIC16LF1559. Three channels (AN0, AN1 and AN2) can be selected by both ADC1 and ADC2. The following channels can be selected by either of the ADCs:

- AN<27:0> pins
- Temperature Indicator
- FVR Buffer 1
- VREFH

The CHSx bits of the ADxCON0 register determine which channel is connected to the sample and hold circuit of ADCx.

When changing channels, a delay (TACQ) is required before starting the next conversion. Refer to [Section 15.2.6 “Individual ADC Conversion Procedure”](#) for more information.

15.1.3 ADC VOLTAGE REFERENCE

The ADC module uses a positive and a negative voltage reference. The positive reference is labeled VREFH and the negative reference is labeled VREFL.

The positive voltage reference (VREFH) is selected by the ADPREF bits in the ADCON1 register. The positive voltage reference source can be:

- VREF+ pin
- VDD

The negative voltage reference (VREFL) source is:

- VSS

15.1.4 CONVERSION CLOCK

The source of the conversion clock is software selectable via the ADCS bits of the ADCON1 register. There are seven possible clock options:

- Fosc/2
- Fosc/4
- Fosc/8
- Fosc/16
- Fosc/32
- Fosc/64
- FRC (internal RC oscillator)

The time to complete one bit conversion is defined as TAD. One full 10-bit conversion requires 11.5 TAD periods as shown in [Figure 15-2](#).

For correct conversion, the appropriate TAD specification must be met. Refer to the ADC conversion requirements in [Section 25.0 “Electrical Specifications”](#) for more information. [Table 15-1](#) gives examples of appropriate ADC clock selections.

Note: Unless using the FRC, any changes in the system clock frequency will change the ADC clock frequency, which may adversely affect the ADC result.

TABLE 15-1: ADC CLOCK PERIOD (T_{AD}) vs. DEVICE OPERATING FREQUENCIES⁽¹⁾

ADC Clock Period (T _{AD})		Device Frequency (F _{osc})					
ADC Clock Source	ADCS<2:0>	32 MHz	20 MHz	16 MHz	8 MHz	4 MHz	1 MHz
F _{osc} /2	000	62.5 ns	100 ns	125 ns	250 ns	500 ns	2.0 μs
F _{osc} /4	100	125 ns	200 ns	250 ns	500 ns	1.0 μs	4.0 μs
F _{osc} /8	001	250 ns	400 ns	500 ns	1.0 μs	2.0 μs	8.0 μs
F _{osc} /16	101	500 ns	800 ns	1.0 μs	2.0 μs	4.0 μs	16.0 μs
F _{osc} /32	010	1.0 μs	1.6 μs	2.0 μs	4.0 μs	8.0 μs	32.0 μs
F _{osc} /64	110	2.0 μs	3.2 μs	4.0 μs	8.0 μs	16.0 μs	64.0 μs
FRC	x11	1.0-6.0 μs	1.0-6.0 μs	1.0-6.0 μs	1.0-6.0 μs	1.0-6.0 μs	1.0-6.0 μs

Legend: Shaded cells are outside of recommended range.

Note 1: The T_{AD} period when using the FRC clock source can fall within a specified range, (see T_{AD} parameter). The T_{AD} period when using the FOSC-based clock source can be configured for a more precise T_{AD} period. However, the FRC clock source must be used when conversions are to be performed with the device in Sleep mode.

FIGURE 15-2: ANALOG-TO-DIGITAL CONVERSION T_{AD} CYCLES

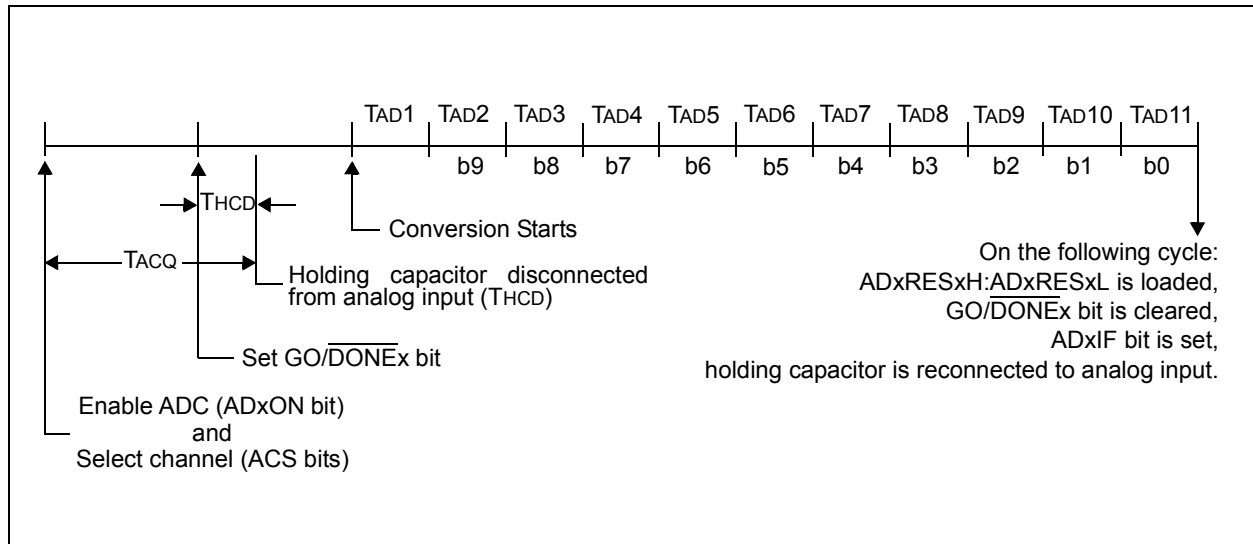

PIC16LF1554/1559

15.1.5 INTERRUPTS

The ADC module allows for the ability to generate an interrupt upon completion of an Analog-to-Digital conversion. The ADCx interrupt flag is the ADxIF bit in the PIRx register. The ADCx interrupt enable is the ADxIE bit in the PIEx register. The ADxIF bit must be cleared in software.

- Note 1:** The ADxIF bit is set at the completion of every conversion, regardless of whether or not the ADCx interrupt is enabled.
- 2:** The ADC operates during Sleep only when the FRC oscillator is selected.

This interrupt can be generated while the device is operating or while in Sleep. If the device is in Sleep, the interrupt will wake-up the device. Upon waking from Sleep, the next instruction following the SLEEP instruction is always executed. If the user is attempting to wake-up from Sleep and resume in-line code execution, the GIE and PEIE bits of the INTCON register must be disabled. If the GIE and PEIE bits of the INTCON register are enabled, execution will switch to the Interrupt Service Routine.

15.1.6 RESULT FORMATTING

The 10-bit ADC conversion result can be supplied in two formats, left justified or right justified. The ADFM bit of the ADCON1/ADCOMCON register controls the output format.

Figure 15-3 shows the two output formats.

FIGURE 15-3: 10-BIT ADC CONVERSION RESULT FORMAT

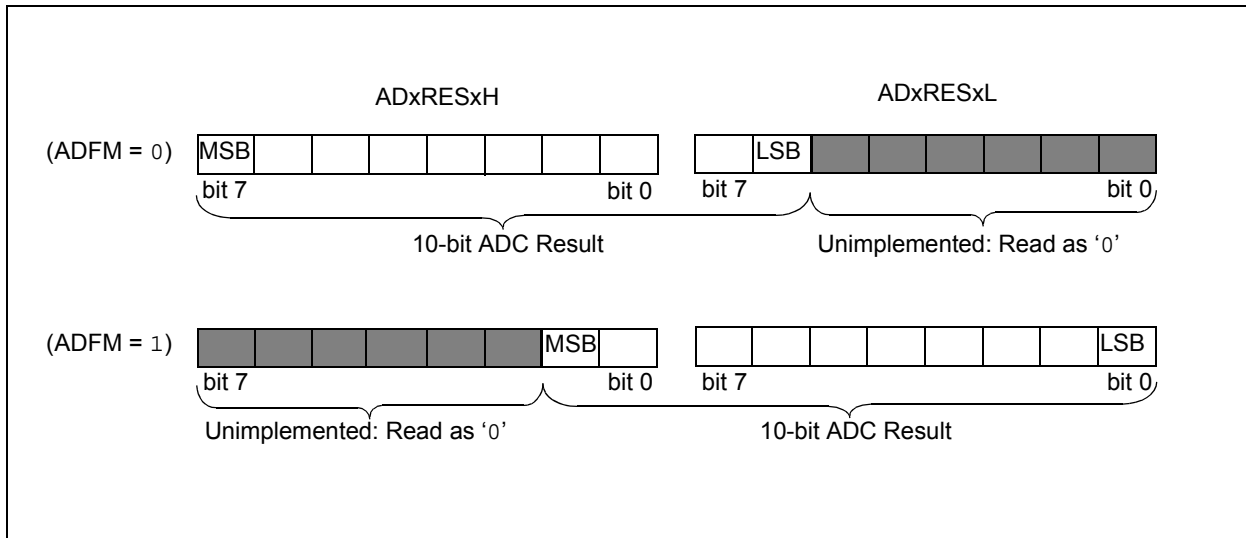

15.2 ADC Operation

15.2.1 STARTING A CONVERSION

To enable the ADCx module, the ADxON bit of the ADxCON0 register must be set to a '1'. Setting the GO/DONEx bit of the ADxCON0 register to a '1' will start the Analog-to-Digital Conversion.

Setting the GO/DONE_ALL bit of the ADCON1/ADCOMCON register to a '1' will start the Analog-to-Digital conversion for both ADC1 and ADC2, which is called synchronized conversion.

Note: The GO/DONEx bit should not be set in the same instruction that turns on the ADC. Refer to [Section 15.2.6 “Individual ADC Conversion Procedure”](#).

15.2.2 COMPLETION OF A CONVERSION

When the conversion is complete, the ADC module will:

- Clear the GO/DONEx bit
- Clear the GO/DONE_ALL bit if a synchronized conversion is done
- Set the ADxIF interrupt flag bit
- Update the ADxRESxH and ADxRESxL registers with new conversion result

Note: Only ADxRES0 will be updated after a single sample conversion. The completion of a double sample conversion will update both ADxRES0 and ADxRES1 registers. Refer to [Section 16.1.6 “Double Sample Conversion”](#) for more information.

15.2.3 TERMINATING A CONVERSION

If a conversion must be terminated before completion, the GO/DONEx bit can be cleared in software. If the GO/DONE_ALL bit is cleared in software, the synchronized conversion will stop. The ADxRESxH and ADxRESxL registers will be updated with the partially complete Analog-to-Digital conversion sample. Incomplete bits will match the last bit converted.

Note: A device Reset forces all registers to their Reset state. Thus, the ADC module is turned off and any pending conversion is terminated.

15.2.4 ADC OPERATION DURING SLEEP

The ADC module can operate during Sleep. This requires the ADC clock source to be set to the FRC option. Performing the ADC conversion during Sleep can reduce system noise. If the ADC interrupt is enabled, the device will wake-up from Sleep when the conversion completes. If the ADC interrupt is disabled, the ADC module is turned off after the conversion completes, although the ADxON bit remains set.

When the ADC clock source is something other than FRC, a SLEEP instruction causes the present conversion to be aborted and the ADC module is turned off, although the ADxON bit remains set.

15.2.5 AUTO-CONVERSION TRIGGER

The auto-conversion trigger allows periodic ADC measurements without software intervention. When a rising edge of the selected source occurs, the GO/DONEx bit is set by hardware.

The auto-conversion trigger source is selected with the TRIGSEL1<2:0> bits of the ADxCON2 register.

Using the auto-conversion trigger does not assure proper ADC timing. It is the user's responsibility to ensure that the ADC timing requirements are met.

See [Table 15-2](#) for auto-conversion sources.

TABLE 15-2: AUTO-CONVERSION SOURCES

Source Peripheral	Trigger Event
Timer0	Timer0 Overflow
Timer1	Timer1 Overflow
Timer2	Timer2 matches PR2
ADTRIG pin	ADTRIG Rising Edge
ADTRIG pin	ADTRIG Falling Edge

PIC16LF1554/1559

15.2.6 INDIVIDUAL ADC CONVERSION PROCEDURE

This is an example procedure for using the ADCx to perform an Analog-to-Digital conversion:

1. Configure Port:
 - Disable pin output driver (Refer to the TRISx register)
 - Configure pin as analog (Refer to the ANSELx register)
2. Configure the ADCx module:
 - Select ADCx conversion clock
 - Configure voltage reference
 - Select ADCx input channel
 - Turn on ADCx module
3. Configure ADCx interrupt (optional):
 - Clear ADCx interrupt flag
 - Enable ADCx interrupt
 - Enable peripheral interrupt
 - Enable global interrupt⁽¹⁾
4. Wait the required acquisition time⁽²⁾.
5. Start conversion by setting the GO/DONEx bit.
6. Wait for ADCx conversion to complete by one of the following:
 - Polling the GO/DONEx bit
 - Waiting for the ADCx interrupt (interrupts enabled)
7. Read ADCx Result.
8. Clear the ADCx interrupt flag (required if interrupt is enabled).

Note 1: The global interrupt can be disabled if the user is attempting to wake-up from Sleep and resume in-line code execution.

2: Refer to [Section 15.4 “ADC Acquisition Requirements”](#).

EXAMPLE 15-1: ADC CONVERSION

```
;This code block configures the ADC1
;for polling, Vdd and Vss references, FRC
;oscillator and AN0 input.
;
;Conversion start and polling for completion
;are included.
;
BANKSEL   ADCON1       ;
MOVLW    B'11110000'  ;Right justify, FRC
;oscillator
MOVWF    ADCON1       ;Vdd is VREFH
BANKSEL   TRISA        ;
BSF      TRISA,0      ;Set RA0 to input
BANKSEL   ANSELA       ;
BSF      ANSELA,0     ;Set RA0 to analog
BANKSEL   ADCON0       ;
MOVLW    B'00000001'  ;Select channel AN0
MOVWF    ADCON0       ;Turn ADC On
MOVLW    .5           ;
MOVWF    AAD1ACQ      ;Acquisition delay
BSF      ADCON0,ADGO  ;Start conversion
BTFSC    ADCON0,ADGO  ;Is conversion done?
GOTO     $-1          ;No, test again
BANKSEL   AD1RES0H     ;
MOVF     AD1RES0H,W   ;Read upper 2 bits
MOVWF    RESULTHI     ;store in GPR space
BANKSEL   AD1RES0L     ;
MOVF     AD1RES0L,W   ;Read lower 8 bits
MOVWF    RESULTLO     ;Store in GPR space
```

15.3 Register Definitions: ADC Control

REGISTER 15-1: ADCON0⁽¹⁾/AD1CON0⁽²⁾: ANALOG-TO-DIGITAL (ADC) 1 CONTROL REGISTER 0

U-0	R/W-0/0	R/W-0/0	R/W-0/0	R/W-0/0	R/W-0/0	R/W-0/0	R/W-0/0
—	CHS14	CHS13	CHS12	CHS11	CHS10	GO/DONE1 ⁽⁴⁾	AD1ON
bit 7							bit 0

Legend:

R = Readable bit	W = Writable bit	U = Unimplemented bit, read as '0'
u = Bit is unchanged	x = Bit is unknown	-n/n = Value at POR and BOR/Value at all other Resets
'1' = Bit is set	'0' = Bit is cleared	

bit 7	Unimplemented: Read as '0'
bit 6-2	CHS1<4:0>: Analog Channel Select bits for ADC1 00000 = Channel 0, (AN0) 00001 = Channel 1, (AN1) 00010 = Channel 2, (AN2) 00011 = Reserved 00100 = Reserved 00101 = Reserved 00110 = Reserved 00111 = Reserved 01000 = Reserved 01001 = Reserved 01010 = Channel 10, (AN10) 01011 = Channel 11, (AN11) 01100 = Channel 12, (AN12) 01101 = Channel 13, (AN13) 01110 = Channel 14, (AN14) ⁽³⁾ 01111 = Channel 15, (AN15) ⁽³⁾ 10000 = Channel 16, (AN16) ⁽³⁾ 10001 = Reserved 10010 = Reserved 10011 = Reserved 10100 = Reserved 10101 = Reserved 10110 = Reserved 10111 = Reserved 11000 = Reserved 11001 = Reserved 11010 = Reserved 11011 = VREFH (ADC Positive Reference) 11100 = Reserved 11101 = Temperature Indicator 11110 = Reserved 11111 = Fixed Voltage Reference (FVREF) Buffer 1 Output
bit 1	GO/DONE1: ADC1 Conversion Status bit ⁽⁴⁾ <u>If AD1ON = 1</u> 1 = ADC conversion in progress. Setting this bit starts the ADC conversion. When the RC clock source is selected, the ADC module waits one instruction before starting the conversion. 0 = ADC conversion not in progress (This bit is automatically cleared by hardware when the ADC conversion is complete.) If this bit is cleared while a conversion is in progress, the conversion will stop and the results of the conversion up to this point will be transferred to the result registers, but the AD1IF interrupt flag bit will not be set. <u>If AD1ON = 0</u> 0 = ADC conversion not in progress
bit 0	AD1ON: ADC Module 1 Enable bit 1 = ADC converter module 1 is operating 0 = ADC converter module 1 is shut off and consumes no operating current. All Analog channels are disconnected.

- Note**
- 1: Bank 1 name is ADCON0.
 - 2: Bank 14 name is AD1CON0.
 - 3: PIC16LF1559 only. Not implemented on PIC16LF1554.
 - 4: When the AD1DSEN bit is set; the GO/DONE1 bit will clear after a second conversion has completed.

PIC16LF1554/1559

REGISTER 15-2: AD2CON0: ANALOG-TO-DIGITAL (ADC) 2 CONTROL REGISTER 0

U-0	R/W-0/0	R/W-0/0	R/W-0/0	R/W-0/0	R/W-0/0	R/W-0/0	R/W-0/0
—	CHS24	CHS23	CHS22	CHS21	CHS20	GO/DONE2 ⁽²⁾	AD2ON
bit 7							bit 0

Legend:

R = Readable bit	W = Writable bit	U = Unimplemented bit, read as '0'
u = Bit is unchanged	x = Bit is unknown	-n/n = Value at POR and BOR/Value at all other Resets
'1' = Bit is set	'0' = Bit is cleared	

bit 7 **Unimplemented:** Read as '0'

bit 6-2 **CHS2<4:0>:** Analog Channel Select bits for ADC2
When AD2ON = 0, all multiplexer inputs are disconnected.

00000 = Channel 0, (AN0)
00001 = Channel 1, (AN1)
00010 = Channel 2, (AN2)
00011 = Reserved
00100 = Reserved
00101 = Reserved
00110 = Reserved
00111 = Reserved
01000 = Reserved
01001 = Reserved
01010 = Reserved
01011 = Reserved
01100 = Reserved
01101 = Reserved
01110 = Reserved
01111 = Reserved
10000 = Reserved
10001 = Reserved
10010 = Reserved
10011 = Reserved
10100 = Channel 20, (AN20)
10101 = Channel 21, (AN21)
10110 = Channel 22, (AN22)
10111 = Channel 23, (AN23)
11000 = Channel 24, (AN24)⁽¹⁾
11001 = Channel 25, (AN25)⁽¹⁾
11010 = Channel 26, (AN26)⁽¹⁾
11011 = VREFH (ADC Positive Reference)
11100 = Reserved
11101 = Temperature Indicator
11110 = Reserved
11111 = Fixed Voltage Reference (FVREF)

bit 1 **GO/DONE2:** ADC2 Conversion Status bit⁽²⁾

If AD2ON = 1

1 = ADC conversion in progress. Setting this bit starts the ADC conversion. When the RC clock source is selected, the ADC Module waits one instruction before starting the conversion.

0 = ADC conversion not in progress (This bit is automatically cleared by hardware when the ADC conversion is complete.)

If this bit is cleared while a conversion is in progress, the conversion will stop and the results of the conversion up to this point will be transferred to the result registers, but the AD2IF interrupt flag bit will not be set.

If AD2ON = 0

0 = ADC conversion not in progress

bit 0 **AD2ON:** ADC Module 2 Enable bit

1 = ADC converter module 2 is operating

0 = ADC converter module 2 is shut off and consumes no operating current. All Analog channels are disconnected.

Note 1: PIC16LF1559 only. Not implemented on PIC16LF1554.

Note 2: When the AD2DSEN bit is set, the GO/DONE2 bit will clear after a second conversion has completed.

REGISTER 15-3: ADCON1⁽¹⁾/ADCOMCON⁽²⁾: ADC CONTROL REGISTER 1

R/W-0/0	R/W-0/0	R/W-0/0	R/W-0/0	U-0	R/W-0/0	R/W-0/0	R/W-0/0
ADFM	ADCS<2:0>		—	GO/DONE_ALL	ADPREF<1:0>		
bit 7							bit 0

Legend:

R = Readable bit	W = Writable bit	U = Unimplemented bit, read as '0'
u = Bit is unchanged	x = Bit is unknown	-n/n = Value at POR and BOR/Value at all other Resets
'1' = Bit is set	'0' = Bit is cleared	

- bit 7 **ADFM:** ADC Result Format Select bit
 1 = Right justified. Six Most Significant bits of ADxRESxH are set to '0' when the conversion result is loaded.
 0 = Left justified. Six Least Significant bits of ADxRESxL are set to '0' when the conversion result is loaded.
- bit 6-4 **ADCS<2:0>:** ADC Conversion Clock Select bits
 000 = Fosc/2
 001 = Fosc/8
 010 = Fosc/32
 011 = FRC (clock supplied from an internal RC oscillator)
 100 = Fosc/4
 101 = Fosc/16
 110 = Fosc/64
 111 = FRC (clock supplied from an internal RC oscillator)
- bit 3 **Unimplemented:** Read as '0'
- bit 2 **GO/DONE_ALL⁽³⁾:** Synchronized ADC Conversion Status bit
 1 = Synchronized ADC conversion in progress. Setting this bit starts conversion in any ADC with ADxON = 1.
 0 = Synchronized ADC conversion completed/ not in progress.
- bit 1-0 **ADPREF<1:0>:** ADC Positive Voltage Reference Configuration bits
 00 = VREFH is connected to VDD
 01 = Reserved
 10 = VREFH is connected to external VREF+ pin⁽⁴⁾
 11 = VREFH is connected to internal Fixed Voltage Reference.

- Note 1:** Bank 1 name is ADCON1.
2: Bank 14 name is ADCOMCON.
3: Setting this bit triggers the GO/DONE_x bits in both ADCs. Each ADC will run a conversion according to its control register settings. This bit reads as an OR of the individual GO/DONE_x bits.
4: When selecting the VREF+ pin as the source of the positive reference, be aware that a minimum voltage specification exists. See [Section 25.0 "Electrical Specifications"](#) for details.

PIC16LF1554/1559

REGISTER 15-4: ADxCON2: ADC CONTROL REGISTER 2

U-0	R/W-0/0	R/W-0/0	R/W-0/0	U-0	U-0	U-0	U-0
—	TRIGSELx<2:0>			—	—	—	—
bit 7							bit 0

Legend:

R = Readable bit	W = Writable bit	U = Unimplemented bit, read as '0'
u = Bit is unchanged	x = Bit is unknown	-n/n = Value at POR and BOR/Value at all other Resets
'1' = Bit is set	'0' = Bit is cleared	

bit 7 **Unimplemented:** Read as '0'

bit 6-4 **TRIGSELx<2:0>:** Auto-Conversion Trigger Selection bits

000 = No Auto Conversion Trigger selected

001 = Reserved

010 = Reserved

011 = Timer0 Overflow⁽¹⁾

100 = Timer1 Overflow⁽¹⁾

101 = Timer2 Match to PR2⁽¹⁾

110 = ADTRIG Rising Edge

111 = ADTRIG Falling Edge

bit 3-0 **Unimplemented:** Read as '0'

Note 1: Signal also sets its corresponding interrupt flag.

REGISTER 15-5: ADxRESxH: ADC RESULT REGISTER HIGH (ADxRESxH) ADFM = 0

R/W-x/u	R/W-x/u	R/W-x/u	R/W-x/u	R/W-x/u	R/W-x/u	R/W-x/u	R/W-x/u
ADRES<9:2>							
bit 7							bit 0

Legend:

R = Readable bit	W = Writable bit	U = Unimplemented bit, read as '0'
u = Bit is unchanged	x = Bit is unknown	-n/n = Value at POR and BOR/Value at all other Resets
'1' = Bit is set	'0' = Bit is cleared	

bit 7-0 **ADRES<9:2>:** ADC Result Register bits

Upper eight bits of 10-bit conversion result

REGISTER 15-6: ADxRESxL: ADC RESULT REGISTER LOW (ADxRESxL) ADFM = 0

R/W-x/u	R/W-x/u	R/W-x/u	R/W-x/u	R/W-x/u	R/W-x/u	R/W-x/u	R/W-x/u
ADRES<1:0>							
bit 7							bit 0

Legend:

R = Readable bit	W = Writable bit	U = Unimplemented bit, read as '0'
u = Bit is unchanged	x = Bit is unknown	-n/n = Value at POR and BOR/Value at all other Resets
'1' = Bit is set	'0' = Bit is cleared	

bit 7-6 **ADRES<1:0>**: ADC Result Register bits
Lower two bits of 10-bit conversion result

bit 5-0 **Reserved**: Do not use.

REGISTER 15-7: ADxRESxH: ADC RESULT REGISTER HIGH (ADxRESxH) ADFM = 1

R/W-x/u	R/W-x/u	R/W-x/u	R/W-x/u	R/W-x/u	R/W-x/u	R/W-x/u	R/W-x/u
—	—	—	—	—	—	ADRES<9:8>	
bit 7							bit 0

Legend:

R = Readable bit	W = Writable bit	U = Unimplemented bit, read as '0'
u = Bit is unchanged	x = Bit is unknown	-n/n = Value at POR and BOR/Value at all other Resets
'1' = Bit is set	'0' = Bit is cleared	

bit 7-2 **Reserved**: Do not use.

bit 1-0 **ADRES<9:8>**: ADC Result Register bits
Upper two bits of 10-bit conversion result

REGISTER 15-8: ADxRESxL: ADC RESULT REGISTER LOW (ADxRESxL) ADFM = 1

R/W-x/u	R/W-x/u	R/W-x/u	R/W-x/u	R/W-x/u	R/W-x/u	R/W-x/u	R/W-x/u
ADRES<7:0>							
bit 7							bit 0

Legend:

R = Readable bit	W = Writable bit	U = Unimplemented bit, read as '0'
u = Bit is unchanged	x = Bit is unknown	-n/n = Value at POR and BOR/Value at all other Resets
'1' = Bit is set	'0' = Bit is cleared	

bit 7-0 **ADRES<7:0>**: ADC Result Register bits
Lower eight bits of 10-bit conversion result

PIC16LF1554/1559

15.4 ADC Acquisition Requirements

For the ADC to meet its specified accuracy, the charge holding capacitor (CHOLD) must be allowed to fully charge to the input channel voltage level. The Analog Input model is shown in Figure 15-4. The source impedance (RS) and the internal sampling switch (RSS) impedance directly affect the time required to charge the capacitor CHOLD. The sampling switch (RSS) impedance varies over the device voltage (VDD), refer to Figure 15-4. **The maximum recommended impedance for analog sources is 10 kΩ.**

As the source impedance is decreased, the acquisition time may be decreased. After the analog input channel is selected (or changed), an ADC acquisition must be done before the conversion can be started. To calculate the minimum acquisition time, Equation 15-1 may be used. This equation assumes that 1/2 LSB error is used (1,024 steps for the ADC). The 1/2 LSB error is the maximum error allowed for the ADC to meet its specified resolution.

EQUATION 15-1: ACQUISITION TIME EXAMPLE

Assumptions: Temperature = 50°C and external impedance of 10 kΩ 3.3V VDD

$$\begin{aligned}TACQ &= \text{Amplifier Settling Time} + \text{Hold Capacitor Charging Time} + \text{Temperature Coefficient} \\ &= TAMP + TC + TCOFF \\ &= 2 \mu s + TC + [(Temperature - 25^\circ C)(0.05 \mu s/^\circ C)]\end{aligned}$$

The value for TC can be approximated with the following equations:

$$VAPPLIED \left(1 - \frac{1}{(2^{n+1}) - 1} \right) = VCHOLD \quad ;[1] \text{ VCHOLD charged to within } 1/2 \text{ lsb}$$

$$VAPPLIED \left(1 - e^{-\frac{TC}{RC}} \right) = VCHOLD \quad ;[2] \text{ VCHOLD charge response to VAPPLIED}$$

$$VAPPLIED \left(1 - e^{-\frac{TC}{RC}} \right) = VAPPLIED \left(1 - \frac{1}{(2^{n+1}) - 1} \right) \quad ;\text{combining [1] and [2]}$$

Note: Where n = number of bits of the ADC.

Solving for TC:

$$\begin{aligned}TC &= -CHOLD(RIC + RSS + RS) \ln(1/2047) \\ &= -15 \text{ pF}(1\text{k}\Omega + 7\text{k}\Omega + 10\text{k}\Omega) \ln(0.0004885) \\ &= 2.06 \mu s\end{aligned}$$

$$\begin{aligned}\text{Therefore: } TACQ &= 2\mu s + 2.06\mu s + [(50^\circ C - 25^\circ C)(0.05\mu s/^\circ C)] \\ &= 5.31 \mu s\end{aligned}$$

Note 1: The reference voltage (VRPOS) has no effect on the equation, since it cancels itself out.

2: The charge holding capacitor (CHOLD) is not discharged after each conversion.

3: The maximum recommended impedance for analog sources is 10 kΩ. This is required to meet the pin leakage specification.

4: The calculation above assumed CHOLD = 15pF. This value can be larger than 15pF by setting the AADxCAP register.

FIGURE 15-4: ANALOG INPUT MODEL

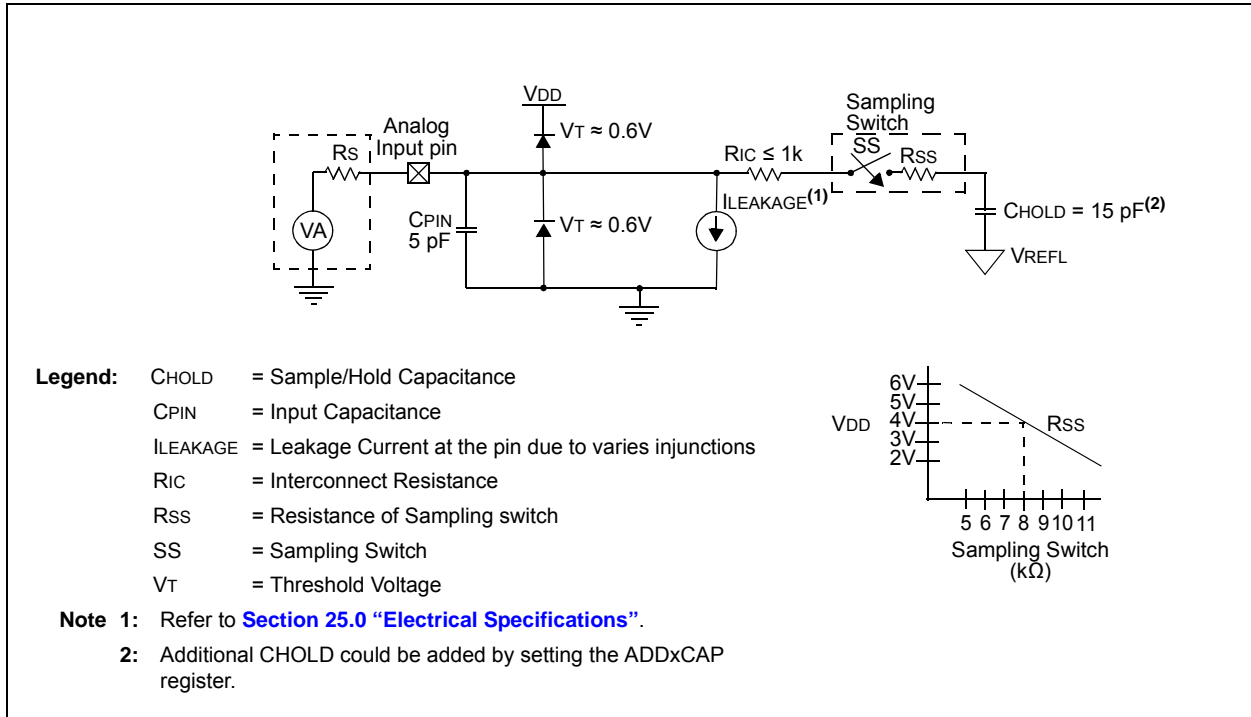
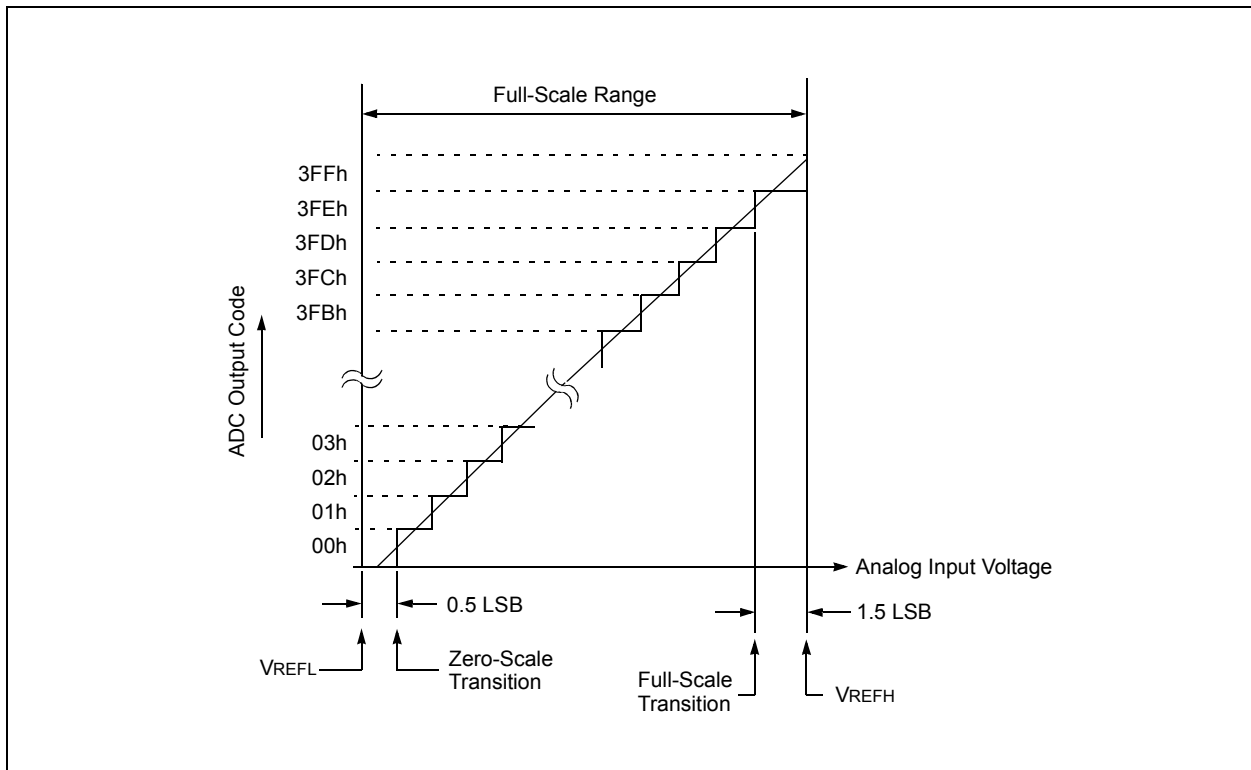

FIGURE 15-5: ADC TRANSFER FUNCTION



PIC16LF1554/1559

TABLE 15-3: SUMMARY OF REGISTERS ASSOCIATED WITH ADC

Name	Bit 7	Bit 6	Bit 5	Bit 4	Bit 3	Bit 2	Bit 1	Bit 0	Register on Page
ADCON0/ AD1CON0	—	CHS14	CHS13	CHS12	CHS11	CHS10	GO/ \overline{DONE} 1	AD1ON	133
AD2CON0	—	CHS24	CHS23	CHS22	CHS21	CHS20	GO/ \overline{DONE} 2	AD2ON	134
ADCON1/ ADCOMCON	ADFM	ADCS<2:0>			—	GO/ \overline{DONE} _ALL	ADPREF<1:0>		135
ADxCON2	—	TRIGSELx<2:0>			—	—	—	—	136
ADxRESxH	ADC Result Register High								136, 137
ADxRESxL	ADC Result Register Low								137, 137
ANSELA	—	—	ANSA5	ANSA4	—	ANSA2	ANSA1	ANSA0	109
ANSELB	ANSB7	ANSB6	ANSB5	ANSB4	—	—	—	—	113
ANSELC	ANSC7	ANSC6	ANSC5	ANSC4	ANSC3	ANSC2	ANSC1	ANSC0	117
INTCON	GIE	PEIE	TMR0IE	INTE	IOCIE	TMR0IF	INTF	IOCIF	77
PIE1	TMR1GIE	AD1IE	RCIE	TXIE	SSP1IE	—	TMR2IE	TMR1IE	78
PIR1	TMR1GIF	AD1IF	RCIF	TXIF	SSP1IF	—	TMR2IF	TMR1IF	80
TRISA	—	—	TRISA5	TRISA4	— ⁽¹⁾	TRISA2	TRISA1	TRISA0	108
TRISB	TRISB7	TRISB6	TRISB5	TRISB4	—	—	—	—	112
TRISC	TRISC7	TRISC6	TRISC5	TRISC4	TRISC3	TRISC2	TRISC1	TRISC0	116
FVRCON	FVREN	FVRRDY	TSEN	TSRNG	—	—	ADFVR<1:0>		124

Legend: x = unknown, u = unchanged, — = unimplemented read as '0', q = value depends on condition. Shaded cells are not used for ADC module.

Note 1: Unimplemented, read as '1'.

16.0 HARDWARE CAPACITIVE VOLTAGE DIVIDER (CVD) MODULE

The hardware Capacitive Voltage Divider (CVD) module is a peripheral, which allows the user to perform a relative capacitance measurement on any ADC channel using the internal ADC sample and hold capacitance as a reference. This relative capacitance measurement can be used to implement capacitive touch or proximity sensing applications.

The CVD operation begins with the ADC's internal sample and hold capacitor (CHOLD) being disconnected from the path which connects it to the external capacitive sensor node. While disconnected, CHOLD is pre-charged to VDD or VSS, while the path to the sensor node is also discharged to VDD or VSS. Typically, this node is discharged to the level opposite that of CHOLD. When the pre-charge phase is complete, the VDD/VSS bias paths for the two nodes are shut off and CHOLD and the path to the external sensor node are re-connected, at which time the acquisition phase of the CVD operation begins. During acquisition, a capacitive voltage divider is formed between the pre-charged CHOLD the and sensor nodes, which results in a final voltage level settling on CHOLD, which is determined by the capacitances and pre-charge levels of the two nodes involved. After acquisition, the ADC converts the voltage level held on CHOLD. This process is then usually repeated with the selected pre-charge levels for both the CHOLD and the inverted sensor nodes. [Figure 16-1](#) shows the waveform for two inverted CVD measurements, which is also known as differential CVD measurement.

In a typical application, an Analog-to-Digital Converter (ADC) channel is attached to a pad on a Printed Circuit Board (PCB), which is electrically isolated from the end user. A capacitive change is detected on the ADC channel using the CVD conversion method when the end user places a finger over the PCB pad, the developer then can implement software to detect a touch or proximity event. Key features of this module include:

- Automated double sample conversions
- Two sets of result registers
- Inversion of second sample
- 7-bit pre-charge timer
- 7-bit acquisition timer
- Two guard ring output drives
- Adjustable sample and hold capacitor array
- Simultaneous CVD sampling on two ADCs

Note: For more information on capacitive voltage divider sensing method refer to the Application Note AN1478, “*mTouch® Sensing Solution Acquisition Methods Capacitive Voltage Divider*” (DS01478).

PIC16LF1554/1559

FIGURE 16-1: DIFFERENTIAL CVD MEASUREMENT WAVEFORM

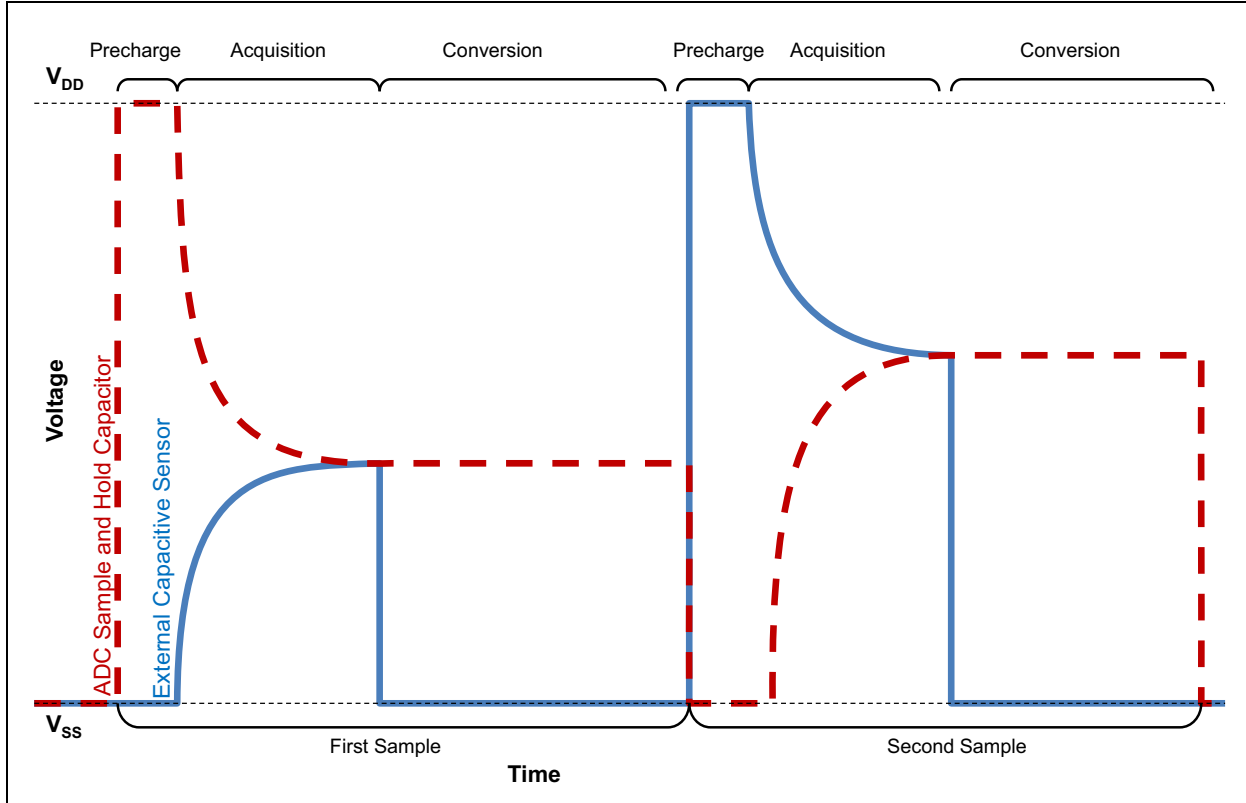
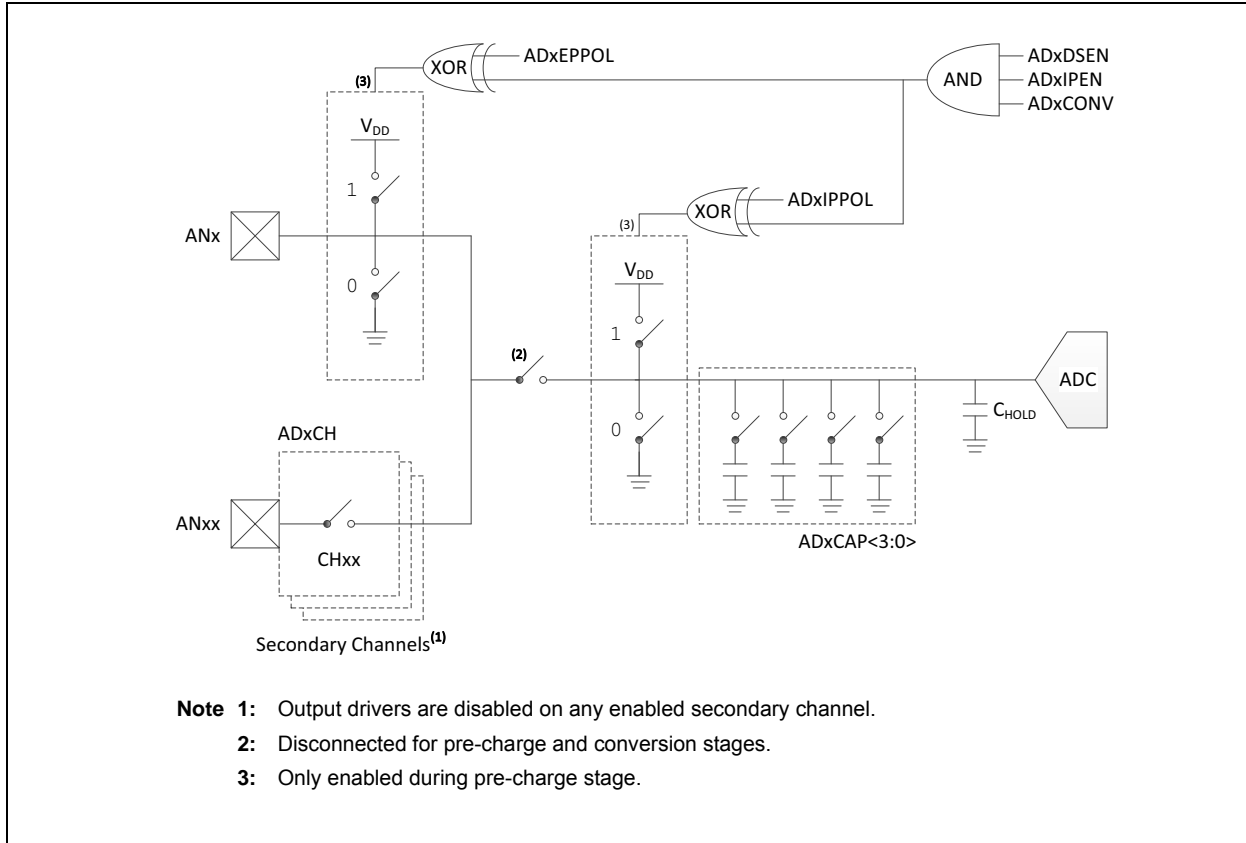

FIGURE 16-2: HARDWARE CAPACITIVE VOLTAGE DIVIDER BLOCK DIAGRAM



16.1 Hardware CVD Operation

Capacitive Voltage Divider is a charge averaging capacitive sensing method. The hardware CVD module will automate the process of charging, averaging between the external sensor and the internal ADC sample and hold capacitor, and then initiating the ADC conversions. The whole process can be expanded into three stages: pre-charge, acquisition, and conversion. See [Figure 16-5](#) for basic information on the timing of three stages.

16.1.1 PRE-CHARGE TIMER

The pre-charge stage is an optional 1-127 instruction/TAD cycle time delay used to put the external ADC channel and the internal sample and hold capacitor (CHOLD) into pre-conditioned states. The pre-charge stage of conversion is enabled by writing a non-zero value to the ADxPRE<6:0> bits of the AADxPRE register. This stage is initiated when a conversion sequence is started by either the GO/DONEx, GO/DONE_ALL bit or a Special Event Trigger. When initiating an ADC conversion, if the ADxPRE bits are cleared, this stage is skipped.

During the pre-charge time, CHOLD is disconnected from the outer portion of the sample path that leads to the external capacitive sensor and is connected to either VDD or VSS, depending on the value of the ADxEPPOL bit of the AADxCON3 register. At the same time, the port pin logic of the selected analog channel is overridden to drive a digital high or low out, in order to pre-charge the outer portion of the ADC's sample path, which includes the external sensor. The output polarity of this override is determined by the ADxEPPOL bit of the AADxCON3 register.

Even though the analog channel of the pin is selected, the analog multiplexer is forced open during the pre-charge stage. The ADC multiplex or logic is overridden and disabled only during the pre-charge time.

16.1.2 ACQUISITION TIMER

The acquisition timer controls the time allowed to acquire the signal to be sampled. The acquisition delay time is from 1 to 127 instruction/TAD cycles and is used to allow the voltage on the internal sample and hold capacitor (CHOLD) to settle to a final value through charge averaging. The acquisition time of conversion is enabled by writing a non-zero value to the AADxACQ<6:0> bits of the AADxACQ register. When the acquisition time is enabled, the time starts immediately following the pre-charge stage. If the ADxPRE<6:0> bits of the AADxPRE register are set to zero, the acquisition time is initiated by either setting the GO/DONEx, GO/DONE_ALL bit or a Special Event Trigger.

At the start of the acquisition stage, the port pin logic of the selected analog channel is again overridden to turn off the digital high/low output drivers so that they do not affect the final result of charge averaging. Also, the selected ADC channel is connected to CHOLD. This allows charge averaging to proceed between the pre-charged channel and the CHOLD capacitor.

16.1.3 STARTING A CONVERSION

To enable the ADC module, the ADxCON bit of the AADxCON0 register must be set. Setting the GO/DONEx, GO/DONE_ALL or by the Special Event Trigger inputs will start the Analog-to-Digital conversion.

Once a conversion begins, it proceeds until complete, while the ADxON bit is set. If the ADxON bit is cleared, the conversion is halted. The GO/DONEx bit of the AADxCON0 register indicates that a conversion is occurring, regardless of the starting trigger.

Note: The GO/DONEx bit should not be set in the same instruction that turns on the ADC. Refer to [Section 16.1.10 “Hardware CVD Double Conversion Procedure”](#)

16.1.4 COMPLETION OF A CONVERSION

When the conversion is complete, the ADC module will:

- Clear the GO/DONEx bit of the AADxCON0 register or clear the GO/DONE_ALL bit of the AADCON1 register if synchronized conversion is used.
- Set the ADxIF interrupt flag bit of the PIRx register.
- Update the AADxRESxH and AADxRESxL registers with new conversion results.

PIC16LF1554/1559

16.1.5 TERMINATING A CONVERSION

If a conversion must be terminated before completion, clear the GO/DONEx bit. The AADxRESxH and AADxRESxL registers will be updated with the partially complete Analog-to-Digital conversion sample. Incomplete bits will match the last bit converted.

The AADSTAT register can be used to track the status of the hardware CVD module during a conversion.

Note: A device Reset forces all registers to their Reset state. Thus, the ADC module is turned off and any pending conversion is terminated.

16.1.6 DOUBLE SAMPLE CONVERSION

Double sampling can be enabled by setting the AADxSEN bit of the AADxCON3 register. When this bit is set, two conversions are completed each time the GO/DONEx, GO/DONE_ALL bit is set or a Special Event Trigger occurs. The GO/DONEx or GO/DONE_ALL bits remain set for the duration of both conversions and is used to signal the end of the conversion.

Without setting the ADxIPEN bit, the double conversion will have identical charge/discharge on the internal and external capacitor for these two conversions. Setting the ADxIPEN bit prior to a double conversion will allow the user to perform a pseudo-differential CVD measurement by subtracting the results from the double conversion. This is highly recommended for noise immunity purposes.

The result of the first conversion is written to the AADxRES0H and AADxRES0L registers. The second conversion starts two clock cycles after the first has completed, while the GO/DONEx and GO/DONE_ALL bits remain set. When the ADxIPEN bit of AADxCON3 is set, the value used by the ADC for the ADxEPPOL, ADxIPPOL and GRDxPOL bits are inverted. The value stored in those bit locations is unchanged. All other control signals remain unchanged from the first conversion. The result of the second conversion is stored in the AADxRES1H and AADxRES1L registers. See Figure 16-4 and Figure 16-5 for more information.

16.1.7 GUARD RING OUTPUTS

The guard ring outputs consist of a pair of digital outputs from the hardware CVD module. Each ADC has its own pair of guard ring outputs. This function is enabled by the GRDxAOE and GRDxBOE bits of the AADxGRD register. Polarity of the output is controlled by the GRDxPOL bit.

Once enabled and while ADxON = 1, the guard ring outputs of the ADC are active at all times. The outputs are initialized at the start of the pre-charge stage to match the polarity of the GRDxPOL bit. The guard output signal changes polarity at the start of the acquisition phase. The value stored by the GRDPOL bit does not change. When in Double Sampling mode, the ring output levels are inverted during the second pre-charge and acquisition phases if ADDxSEN = 1 and ADxIPEN = 1. For more information on the timing of the guard ring output, refer to Figure 16-4 and Figure 16-5.

A typical guard ring circuit is displayed in Figure 16-2. CGUARD represents the capacitance of the guard ring trace placed on a PCB board. The user selects values for RA and RB that will create a voltage profile on CGUARD, which will match the selected channel during acquisition.

The purpose of the guard ring is to generate a signal in phase with the CVD sensing signal to minimize the effects of the parasitic capacitance on sensing electrodes. It also can be used as a mutual drive for mutual capacitive sensing. For more information about active guard and mutual drive, see Application Note AN1478, "mTouch® Sensing Solution Acquisition Methods Capacitive Voltage Divider" (DS01478).

FIGURE 16-3: GUARD RING CIRCUIT

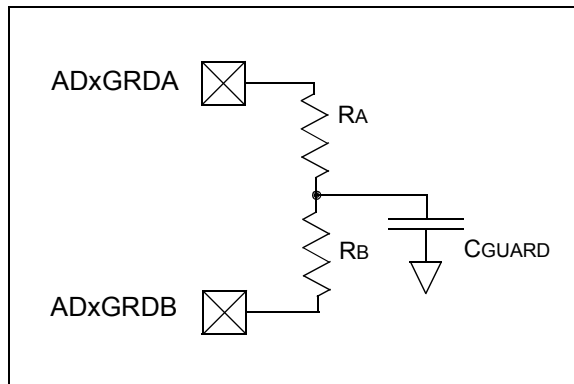
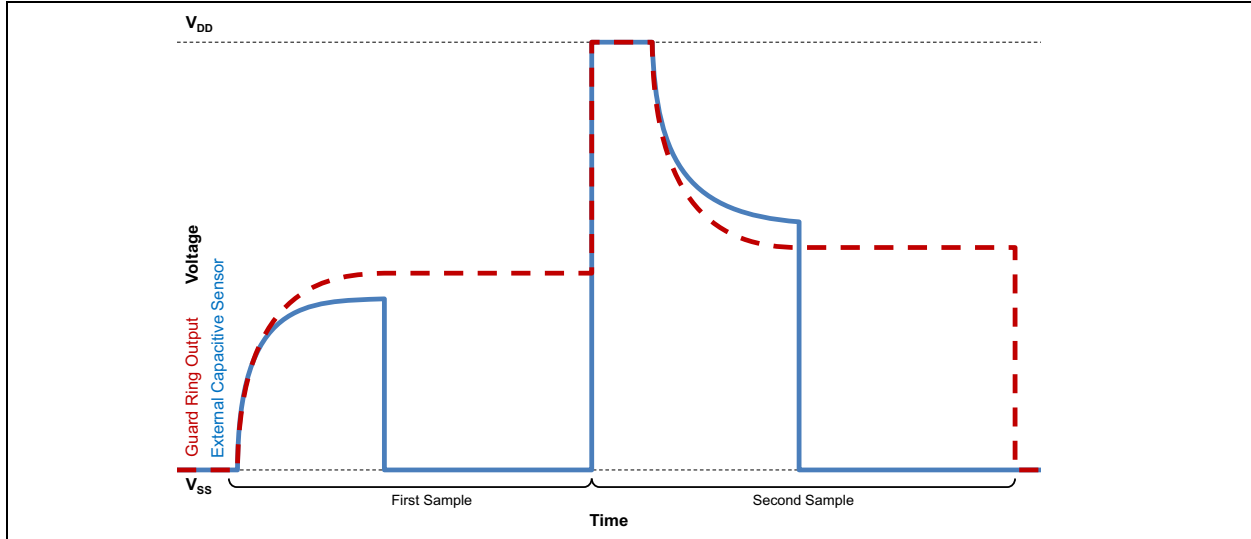

FIGURE 16-4: DIFFERENTIAL CVD WITH GUARD RING OUTPUT WAVEFORM



16.1.8 ADDITIONAL SAMPLE AND HOLD CAPACITOR

Additional capacitance can be added in parallel with the sample and hold capacitor (CHOLD) by setting the ADDxCAP<3:0> bits of the AADxCAP register. This bit connects a digitally programmable capacitance to the ADC conversion bus, increasing the effective internal capacitance of the sample and hold capacitor in the ADC module. Each ADC has its own additional capacitance array. This is used to improve the match between internal and external capacitance for a better sensing performance. The additional capacitance does not affect analog performance of the ADC because it is not connected during conversion. See [Figure 16-1](#).

16.1.9 SECONDARY CHANNEL

Each ADC has one primary channel selected by CHx<4:0> bits of the AADxCON0 register. Multiple secondary channels can be connected to the ADC conversion bus by setting the bits in the AADxCH register. This allows a combined CVD scan on multiple ADC channels, which is beneficial for low-power and proximity capacitive sensing.

Each secondary channel is forced to input. The ANSELx bit for secondary channel is still under user control. During the pre-charge stage, the output drivers on each secondary channel will be overridden by the hardware CVD module and do exactly what the output drivers on the ADC's primary channel are configured to do.

Both the primary and secondary channels are connected to the ADC as soon as the channels are selected by the CHx<4:0> bits of the AADxCON0 register and the bits in the AADxCH register.

FIGURE 16-5: HARDWARE CVD SEQUENCE TIMING DIAGRAM

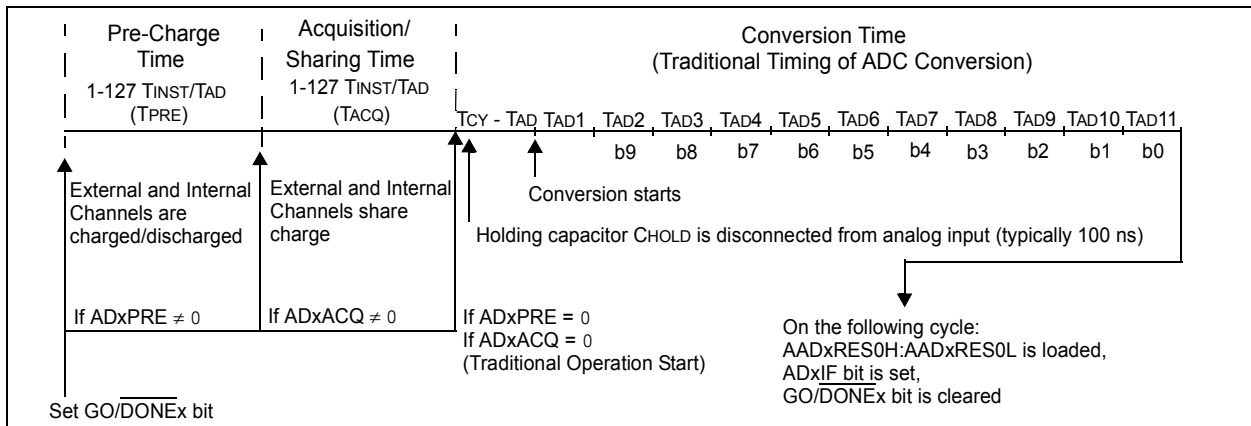

FIGURE 16-6: DOUBLE SAMPLE CONVERSION SEQUENCE (ADDSEN = 1 AND ADIPEN = 0)

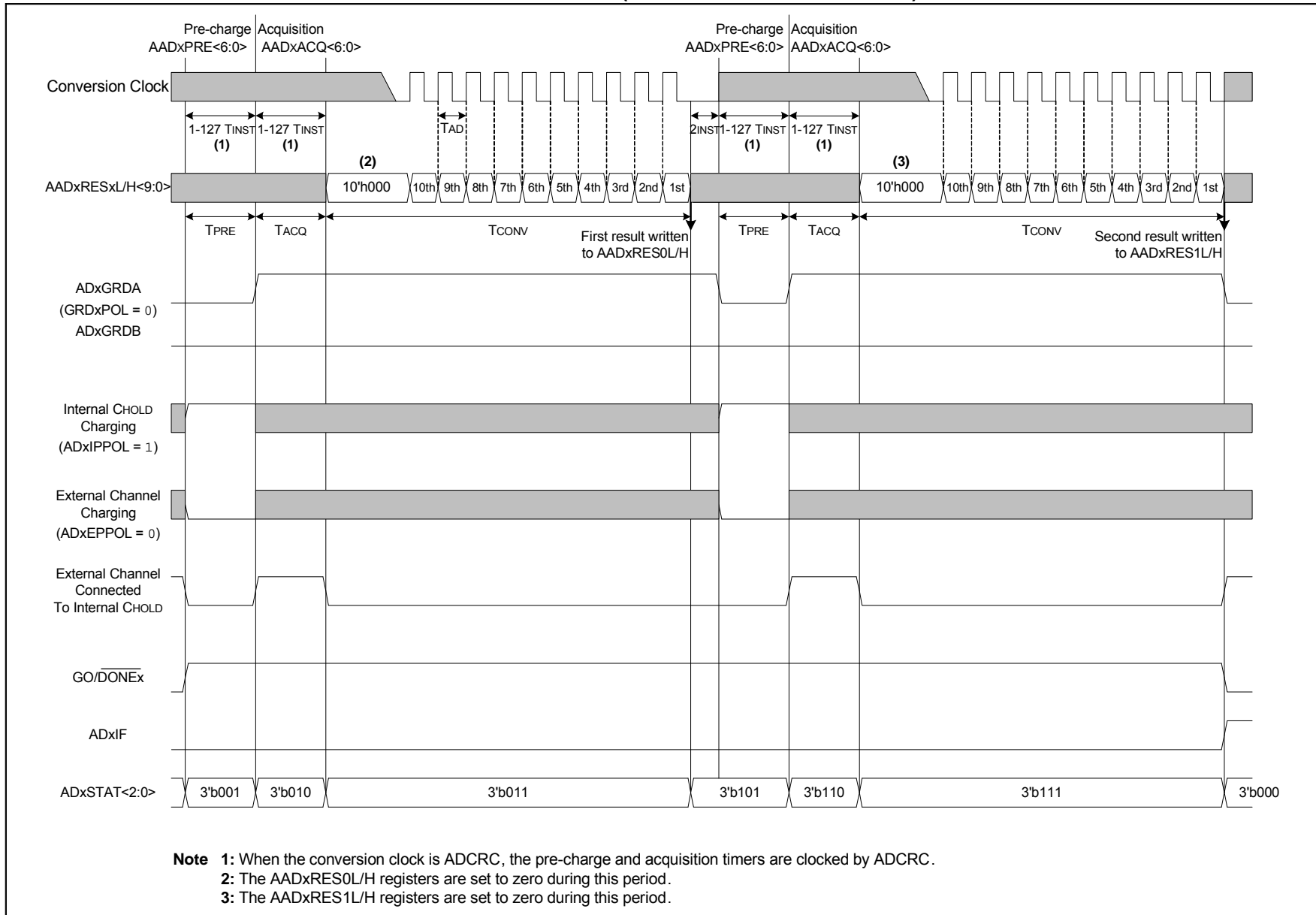
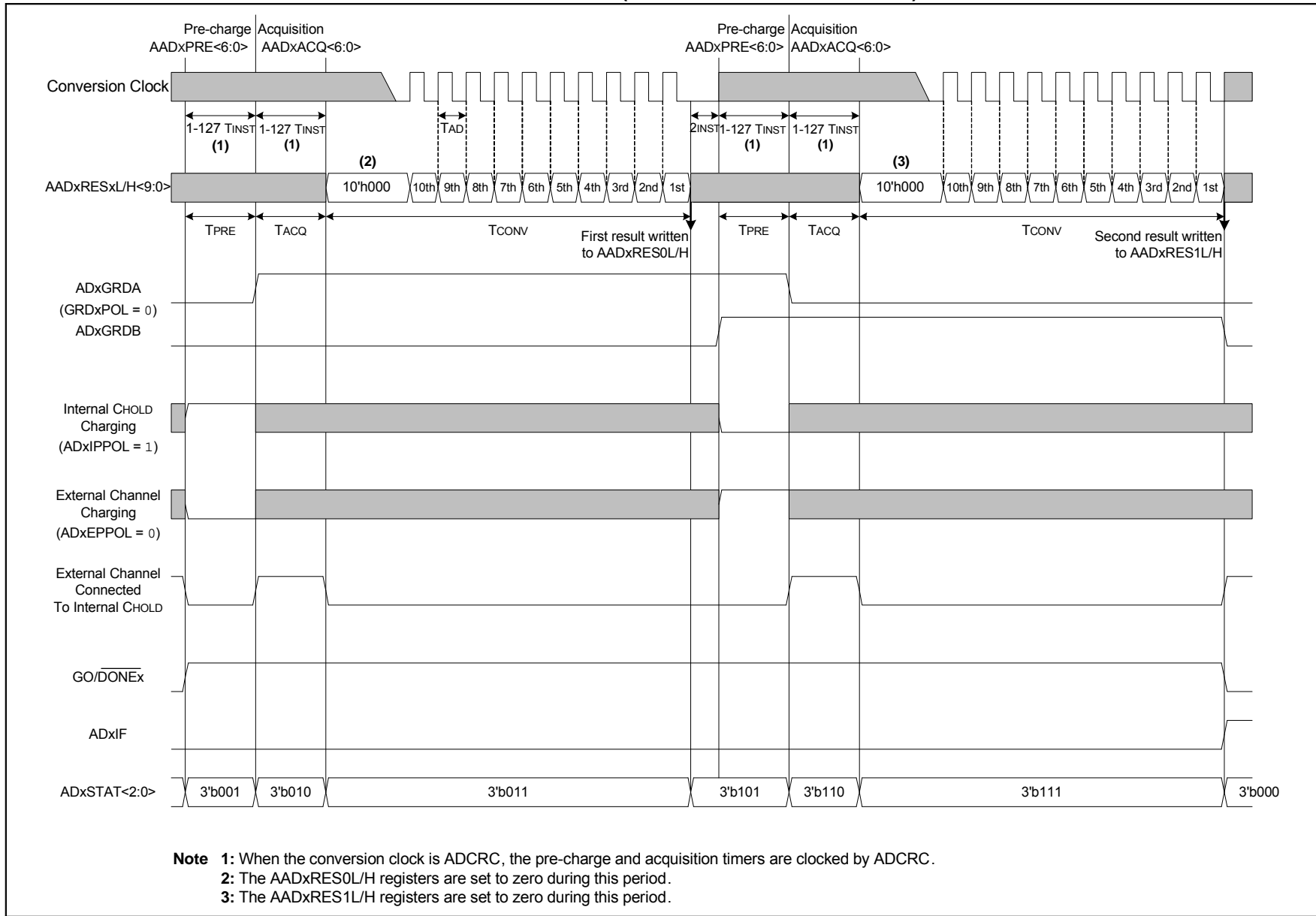

FIGURE 16-7: DOUBLE SAMPLE CONVERSION SEQUENCE (ADDSSEN = 1 AND ADIPEN = 1)



PIC16LF1554/1559

16.1.10 HARDWARE CVD DOUBLE CONVERSION PROCEDURE

This is an example procedure for using hardware CVD to perform a double conversion for differential CVD measurement with active guard drive.

1. Configure Port:
 - Enable pin output driver (Refer to the TRISx register).
 - Configure pin output low (Refer to the LATx register).
 - Disable weak pull-up (Refer to the WPUx register).
2. Configure the ADC module:
 - Select an appropriate ADC conversion clock for your oscillator frequency.
 - Configure voltage reference.
 - Select ADC input channel.
 - Turn on the ADC module.
3. Configure the hardware CVD module:
 - Configure charge polarity and double conversion.
 - Configure pre-charge and acquisition timer.
 - Configure guard ring (optional).
 - Select additional capacitance (optional).
4. Configure ADC interrupt (optional):
 - Clear ADC interrupt flag
 - Enable ADC interrupt
 - Enable peripheral interrupt
 - Enable global interrupt⁽¹⁾
5. Start conversion by setting the $\overline{GO/DONEx}$, $\overline{GO/DONE_ALL}$ bit or by enabling the Special Event Trigger in the ADDxCON2 register.
6. Wait for the ADC conversion to complete by one of the following:
 - Polling the $\overline{GO/DONEx}$ or $\overline{GO/DONE_ALL}$ bit.
 - Waiting for the ADC interrupt (interrupts enabled).
7. Read ADC result:
 - Conversion 1 result in ADDxRES0H and ADDxRES0L
 - Conversion 2 result in ADDxRES1H and ADDxRES1L
8. Clear the ADC interrupt flag (required if interrupt is enabled).

Note 1: The global interrupt can be disabled if the user is attempting to wake-up from Sleep and resume in-line code execution.

EXAMPLE 16-1: HARDWARE CVD DOUBLE CONVERSION

```
;This code block configures the ADC
;for polling, Vdd and Vss references, Fosc/16
;clock and AN0 input.
;
;The Hardware CVD1 will perform an inverted
;double conversion, Guard A and B drive are
;both enabled.
;Conversion start & polling for completion
;are included.
;
BANKSEL    TRISA
BCF        TRISA,0      ;Set RA0 to output
BANKSEL    LATA
BCF        LATA,0      ;RA0 output low
BANKSEL    ANSELA
BCF        ANSELA,0    ;Set RA0 to digital
BANKSEL    WPUA
BCF        WPUA,0     ;Disable pull-up on
RA0
;Initialize ADC and Hardware CVD

BANKSEL    AAD1CON0
MOVLW     B'00000001'  ;Select channel AN0
MOVWF     AAD1CON0
BANKSEL    AADCON1
MOVLW     B'11010000'  ;Vdd and Vss VREF
MOVWF     AADCON1
MOVLW     B'00000000'  ;No secondary channel
MOVWF     AAD1CH

BANKSEL    AAD1CON3
MOVLW     B'01000011'  ;Double and inverted
MOVWF     AAD1CON3    ;
BANKSEL    AAD1PRE
MOVLW     .10
MOVWF     AAD1PRE     ;Pre-charge Timer
BANKSEL    AAD1ACQ
MOVLW     .10
MOVWF     AAD1ACQ     ;Acquisition Timer
BANKSEL    AAD1GRD
MOVLW     B'11000000'  ;Guard on A and B
MOVWF     AAD1GRD
BANKSEL    AAD1CAP
MOVLW     B'00000000'  ;No additional
MOVWF     AAD1CAP     ;Capacitance

BANKSEL    AD1CON0
BSF       AD1CON0, GO
BTFSC    AD1CON0, GO
GOTO     $-1          ;No, test again

;RESULTS OF CONVERSIONS 1.
BANKSEL    AAD1RES0H  ;
MOVF      AAD1RES0H,W ;Read upper 2 bits
MOVWF     RESULT0H   ;Store in GPR space
MOVF      AAD1RES0L,W ;Read lower 8 bits
MOVWF     RESULT0L   ;Store in GPR space

;RESULTS OF CONVERSIONS 2.
BANKSEL    AAD1RES1H  ;
MOVF      AAD1RES1H,W ;Read upper 2 bits
MOVWF     RESULT1H   ;Store in GPR space
MOVF      AAD1RES1L,W ;Read lower 8 bits
MOVWF     RESULT1L   ;Store in GPR space
```

16.1.11 HARDWARE CVD REGISTER MAPPING

The hardware CVD module is an enhanced expansion of the standard ADC module as stated in [Section 15.0 “Analog-to-Digital Converter \(ADC\) Module”](#) and is backward compatible with the other devices in this family. Control of the standard ADC1 module uses Bank 1 registers, see [Table 16-1](#). This set of registers is mapped into Bank 14 with the control registers for the hardware CVD module. Although this subset of registers has different names, they are identical. Since the registers for the standard ADC are mapped into the Bank 14 address space, any changes to registers in Bank 1 will be reflected in Bank 14 and vice-versa.

TABLE 16-1: HARDWARE CVD REGISTER MAPPING

[Bank 14 Address]	[Bank 1 Address]
Hardware CVD	ADC
[711h] AAD1CON0 ⁽¹⁾	[09Dh] ADCON0 ⁽¹⁾
[712h] AAD1CON1 ⁽¹⁾	[09Eh] ADCON1 ⁽¹⁾
[713h] AAD1CON2 ⁽¹⁾	[09Fh] ADCON2 ⁽¹⁾
[714h] AAD1CON3	
[715h] AAD1STAT	
[716h] AAD1PRE	
[717h] AAD1ACQ	
[718h] AAD1GRD	
[719h] AAD1CAP	
[71Ah] AAD1RES0L ⁽¹⁾	[09Bh] AD1RES0L ⁽¹⁾
[71Bh] AAD1RES0H ⁽¹⁾	[09Ch] AD1RES0H ⁽¹⁾
[71Ch] AAD1RES1L	
[71Dh] AAD1RES1H	
[71Eh] AAD1CH	

Note 1: Register is mapped in Bank 1 and Bank 14, using different names in each bank.

The ADC2 only has one set of registers in Bank 15. However, letter ‘A’, which stands for advanced, is added to the beginning of each register’s name for legacy ADC control in this chapter. For example, AD2CON0 in [Section 15.0 “Analog-to-Digital Converter \(ADC\) Module”](#) uses the name of AAD2CON0 in this chapter. Please note that this is just an alias name, they still represent the same SFR register address in memory.

PIC16LF1554/1559

16.2 Register Definitions: Hardware CVD Control

REGISTER 16-1: AAD1CON0: HARDWARE CVD 1 CONTROL REGISTER 0^(1,2)

U-0	R/W-0/0	R/W-0/0	R/W-0/0	R/W-0/0	R/W-0/0	R/W-0/0	R/W-0/0
—	CHS14	CHS13	CHS12	CHS11	CHS10	GO/DONE1 ⁽⁴⁾	AD1ON
bit 7							bit 0

Legend:

R = Readable bit	W = Writable bit	U = Unimplemented bit, read as '0'
u = Bit is unchanged	x = Bit is unknown	-n/n = Value at POR and BOR/Value at all other Resets
'1' = Bit is set	'0' = Bit is cleared	

bit 7 **Unimplemented:** Read as '0'

bit 6-2 **CHS1<4:0>:** Analog Channel Select bits for ADC1
When AD1ON = 0, all multiplexer inputs are disconnected.

00000	= Channel 0, (AN0)
00001	= Channel 1, (AN1)
00010	= Channel 2, (AN2)
00011	= Reserved
00100	= Reserved
00101	= Reserved
00110	= Reserved
00111	= Reserved
01000	= Reserved
01001	= Reserved
01010	= Channel 10, (AN10)
01011	= Channel 11, (AN11)
01100	= Channel 12, (AN12)
01101	= Channel 13, (AN13)
01110	= Channel 14, (AN14) ⁽³⁾
01111	= Channel 15, (AN15) ⁽³⁾
10000	= Channel 16, (AN16) ⁽³⁾
10001	= Reserved
10010	= Reserved
10011	= Reserved
10100	= Reserved
10101	= Reserved
10110	= Reserved
10111	= Reserved
11000	= Reserved
11001	= Reserved
11010	= Reserved
11011	= VREFH (ADC Positive Reference)
11100	= Reserved
11101	= Temperature Indicator
11110	= Reserved
11111	= Fixed Voltage Reference (FVREF) Buffer 1 Output

bit 1 **GO/DONE1:** ADC1 Conversion Status bit ⁽⁴⁾

If AD1ON = 1

1 = ADC conversion in progress. Setting this bit starts the ADC conversion. When the RC clock source is selected, the ADC Module waits one instruction before starting the conversion.

0 = ADC conversion not in progress (This bit is automatically cleared by hardware when the ADC conversion is complete.) If this bit is cleared while a conversion is in progress, the conversion will stop and the results of the conversion up to this point will be transferred to the result registers, but the AD1IF interrupt flag bit will not be set.

If AD1ON = 0

0 = ADC conversion not in progress

bit 0 **AD1ON:** ADC Module 1 Enable bit

1 = ADC1 is enabled

0 = ADC1 is disabled and consumes no operating current. All analog channels are disconnected.

- Note**
- 1: Bank 1 name is ADCON0.
 - 2: Bank 14 name is AAD1CON0.
 - 3: PIC16LF1559 only. Not implemented on PIC16LF1554.
 - 4: When the AD1DSEN bit is set; the GO/DONE1 bit will clear after a second conversion has completed.

REGISTER 16-2: AAD2CON0: HARDWARE CVD 2 CONTROL REGISTER 0

U-0	R/W-0/0	R/W-0/0	R/W-0/0	R/W-0/0	R/W-0/0	R/W-0/0	R/W-0/0
—	CHS24	CHS23	CHS22	CHS21	CHS20	GO/DONE2 ⁽²⁾	AD2ON
bit 7							bit 0

Legend:

R = Readable bit	W = Writable bit	U = Unimplemented bit, read as '0'
u = Bit is unchanged	x = Bit is unknown	-n/n = Value at POR and BOR/Value at all other Resets
'1' = Bit is set	'0' = Bit is cleared	

bit 7 **Unimplemented:** Read as '0'

bit 6-2 **CHS2<4:0>:** Analog Channel Select bits for ADC2
When AD2ON = 0, all multiplexer inputs are disconnected.

- 00000 = Channel 0, (AN0)
- 00001 = Channel 1, (AN1)
- 00010 = Channel 2, (AN2)
- 00011 = Reserved
- 00100 = Reserved
- 00101 = Reserved
- 00110 = Reserved
- 00111 = Reserved
- 01000 = Reserved
- 01001 = Reserved
- 01010 = Reserved
- 01011 = Reserved
- 01100 = Reserved
- 01101 = Reserved
- 01110 = Reserved
- 01111 = Reserved
- 10000 = Reserved
- 10001 = Reserved
- 10010 = Reserved
- 10011 = Reserved
- 10100 = Channel 20, (AN20)
- 10101 = Channel 21, (AN21)
- 10110 = Channel 22, (AN22)
- 10111 = Channel 23, (AN23)
- 11000 = Channel 24, (AN24)⁽¹⁾
- 11001 = Channel 25, (AN25)⁽¹⁾
- 11010 = Channel 26, (AN26)⁽¹⁾
- 11011 = VREFH (ADC Positive Reference)
- 11100 = Reserved
- 11101 = Temperature Indicator
- 11110 = Reserved
- 11111 = Fixed Voltage Reference (FVREF) Buffer 1 Output

bit 1 **GO/DONE2:** ADC2 Conversion Status bit ⁽²⁾

If AD2ON = 1

- 1 = ADC conversion in progress. Setting this bit starts the ADC conversion. When the RC clock source is selected, the ADC Module waits one instruction before starting the conversion.
- 0 = ADC conversion not in progress (This bit is automatically cleared by hardware when the ADC conversion is complete.) If this bit is cleared while a conversion is in progress, the conversion will stop and the results of the conversion up to this point will be transferred to the result registers, but the AD2IF interrupt flag bit will not be set.

If AD2ON = 0

- 0 = ADC conversion not in progress

bit 0 **AD2ON:** ADC Module 2 Enable bit

- 1 = ADC2 is enabled
- 0 = ADC2 is disabled and consumes no operating current. All analog channels are disconnected.

Note 1: PIC16LF1559 only. Not implemented on PIC16LF1554.

2: When the AD2DSEN bit is set; the GO/DONE2 bit will clear after a second conversion has completed.

PIC16LF1554/1559

REGISTER 16-3: AAD1CH: HARDWARE CVD 1 SECONDARY CHANNEL SELECT REGISTER^(1,2,3,4)

U-0	R/W-0/0	R/W-0/0	R/W-0/0	R/W-0/0	R/W-0/0	R/W-0/0	R/W-0/0
—	CH16	CH15	CH14	CH13	CH12	CH11	CH10
bit 7							bit 0

Legend:

R = Readable bit	W = Writable bit	U = Unimplemented bit, read as '0'
u = Bit is unchanged	x = Bit is unknown	-n/n = Value at POR and BOR/Value at all other Resets
'1' = Bit is set	'0' = Bit is cleared	

bit 7	Unimplemented: Read as '0'
bit 6	CH16: Channel 16 to ADC1 Connection bit ⁽⁵⁾ 1 = AN16 is connected to ADC1 0 = AN16 is not connected to ADC1
bit 5	CH15: Channel 15 to ADC1 Connection bit ⁽⁵⁾ 1 = AN15 is connected to ADC1 0 = AN15 is not connected to ADC1
bit 4	CH14: Channel 14 to ADC1 Connection bit ⁽⁵⁾ 1 = AN14 is connected to ADC1 0 = AN14 is not connected to ADC1
bit 3	CH13: Channel 13 to ADC1 Connection bit 1 = AN13 is connected to ADC1 0 = AN13 is not connected to ADC1
bit 2	CH12: Channel 12 to ADC1 Connection bit 1 = AN12 is connected to ADC1 0 = AN12 is not connected to ADC1
bit 1	CH11: Channel 11 to ADC1 Connection bit 1 = AN11 is connected to ADC1 0 = AN11 is not connected to ADC1
bit 0	CH10: Channel 10 to ADC1 Connection bit 1 = AN10 is connected to ADC1 0 = AN10 is not connected to ADC1

Note 1: This register selects secondary channels which are connected in parallel to the primary channel selected in AAD1CON0. Pre-charge bias is applied to both the primary and secondary channels.

- 2:** If the same channel is selected as both primary and secondary then the selection as primary takes precedence.
- 3:** Enabling these bits automatically overrides the corresponding TRIS bit to tri-state the selected pin.
- 4:** In the same way that the CHSx bits in AAD1CON0 only close the switch when the ADC is enabled, these connections and the TRISx overrides are only active if the ADC is enabled by setting ADxON.
- 5:** PIC16LF1559 only. Unimplemented/Read as '0' on PIC16LF1554.

REGISTER 16-4: AAD2CH: HARDWARE CVD 2 SECONDARY CHANNEL SELECT REGISTER^(1,2,3,4)

U-0	R/W-0/0	R/W-0/0	R/W-0/0	R/W-0/0	R/W-0/0	R/W-0/0	R/W-0/0
—	CH26	CH25	CH24	CH23	CH22	CH21	CH20
bit 7							bit 0

Legend:

R = Readable bit	W = Writable bit	U = Unimplemented bit, read as '0'
u = Bit is unchanged	x = Bit is unknown	-n/n = Value at POR and BOR/Value at all other Resets
'1' = Bit is set	'0' = Bit is cleared	

- bit 7 **Unimplemented:** Read as '0'
- bit 6 **CH26:** Channel 26 to ADC2 Connection bit⁽⁵⁾
1 = AN26 is connected to ADC2
0 = AN26 is not connected to ADC2
- bit 5 **CH25:** Channel 25 to ADC2 Connection bit⁽⁵⁾
1 = AN25 is connected to ADC2
0 = AN25 is not connected to ADC2
- bit 4 **CH24:** Channel 24 to ADC2 Connection bit⁽⁵⁾
1 = AN24 is connected to ADC2
0 = AN24 is not connected to ADC2
- bit 3 **CH23:** Channel 23 to ADC2 Connection bit
1 = AN23 is connected to ADC2
0 = AN23 is not connected to ADC2
- bit 2 **CH22:** Channel 22 to ADC2 Connection bit
1 = AN22 is connected to ADC2
0 = AN22 is not connected to ADC2
- bit 1 **CH21:** Channel 21 to ADC2 Connection bit
1 = AN21 is connected to ADC2
0 = AN21 is not connected to ADC2
- bit 0 **CH20:** Channel 20 to ADC2 Connection bit
1 = AN20 is connected to ADC2
0 = AN20 is not connected to ADC2

- Note 1:** This register selects secondary channels which are connected in parallel to the primary channel selected in AAD2CON0. Pre-charge bias is applied to both the primary and secondary channels.
- 2:** If the same channel is selected as both primary and secondary then the selection as primary takes precedence.
 - 3:** Enabling these bits automatically overrides the corresponding TRIS bit to tri-state the selected pin.
 - 4:** In the same way that the CHSx bits in AAD2CON0 only close the switch when the ADC is enabled, these connections and the TRISx overrides are only active if the ADC is enabled by setting ADxON.
 - 5:** PIC16LF1559 only. Unimplemented/Read as '0' on PIC16LF1554.

PIC16LF1554/1559

REGISTER 16-5: AADCON1⁽¹⁾/ADCOMCON⁽²⁾: HARDWARE CVD CONTROL REGISTER 1^(1,2)

R/W-0/0	R/W-0/0	R/W-0/0	R/W-0/0	U-0	U-0	R/W-0/0	R/W-0/0
ADFM	ADCS<2:0>		—	GO/DONE_ALL	ADPREF<1:0>		
bit 7						bit 0	

Legend:

R = Readable bit	W = Writable bit	U = Unimplemented bit, read as '0'
u = Bit is unchanged	x = Bit is unknown	-n/n = Value at POR and BOR/Value at all other Resets
'1' = Bit is set	'0' = Bit is cleared	

- bit 7 **ADFM:** ADC Result Format Select bit
 1 = Right justified. Six Most Significant bits of AADxRESxH are set to '0' when the conversion result is loaded.
 0 = Left justified. Six Least Significant bits of AADxRESxL are set to '0' when the conversion result is loaded.
- bit 6-4 **ADCS<2:0>:** ADC Conversion Clock Select bits
 111 = FRC (clock supplied from a dedicated RC oscillator)
 110 = Fosc/64
 101 = Fosc/16
 100 = Fosc/4
 011 = FRC (clock supplied from a dedicated RC oscillator)
 010 = Fosc/32
 001 = Fosc/8
 000 = Fosc/2
- bit 3 **Unimplemented:** Read as '0'
- bit 2 **GO/DONE_ALL⁽³⁾:** Synchronized ADC Conversion Status bit
 1 = Synchronized ADC conversion in progress. Setting this bit starts conversion in any ADC with ADxON = 1.
 0 = Synchronized ADC conversion completed/ not in progress.
- bit 1-0 **ADPREF<1:0>:** ADC Positive Voltage Reference Configuration bits
 00 = VREFH is connected to VDD
 01 = Reserved
 10 = VREFH is connected to external VREF+ pin⁽⁴⁾
 11 = VREFH is connected to internal Fixed Voltage Reference

- Note 1:** Bank 1 name is ADCON1.
2: Bank 14 name is AADCON1/ADCOMCON.
3: Setting this bit triggers the GO/DONE_x bits in both ADCs. Each ADC will run a conversion according to its control register settings. This bit reads as an OR of the individual GO/DONE_x bits.
4: When selecting the VREF+ pin as the source of the positive reference, be aware that a minimum voltage specification exists. See [Section 25.0 "Electrical Specifications"](#) for details.

REGISTER 16-6: AADxCON2: HARDWARE CVD CONTROL REGISTER 2⁽¹⁾

U-0	R/W-0/0	R/W-0/0	R/W-0/0	U-0	U-0	U-0	U-0
—	TRIGSELx<2:0> ⁽¹⁾			—	—	—	—
bit 7				bit 0			

Legend:

R = Readable bit	W = Writable bit	U = Unimplemented bit, read as '0'
u = Bit is unchanged	x = Bit is unknown	-n/n = Value at POR and BOR/Value at all other Resets
'1' = Bit is set	'0' = Bit is cleared	

bit 7 **Unimplemented:** Read as '0'

bit 6-4 **TRIGSELx<2:0>:** Auto-Conversion Trigger Selection bits

- 000 = No Auto Conversion Trigger selected
- 001 = Reserved
- 010 = Reserved
- 011 = Timer0 Overflow⁽²⁾
- 100 = Timer1 Overflow⁽²⁾
- 101 = Timer2 Match to PR2⁽²⁾
- 110 = ADTRIG Rising Edge
- 111 = ADTRIG Falling Edge

bit 3-0 **Unimplemented:** Read as '0'

Note 1: See [Section 16.1.11 "Hardware CVD Register Mapping"](#) for more information.

2: Signal used to set the corresponding interrupt flag.

PIC16LF1554/1559

REGISTER 16-7: AADxCON3: HARDWARE CVD CONTROL REGISTER 3

R/W-0/0	R/W-0/0	U-0	U-0	U-0	U-0	R/W-0/0	R/W-0/0
ADxEPPOL	ADxIPPOL	—	—	—	—	ADxIPEN	ADxDSEN
bit 7						bit 0	

Legend:

R = Readable bit	W = Writable bit	U = Unimplemented bit, read as '0'
u = Bit is unchanged	x = Bit is unknown	-n/n = Value at POR and BOR/Value at all other Resets
'1' = Bit is set	'0' = Bit is cleared	

- bit 7 **ADxEPPOL:** External Pre-charge Polarity bit⁽¹⁾
 1 = Selected channel is connected to VDDIO during pre-charge time
 0 = Selected channel is connected to VSS during pre-charge time
- bit 6 **ADxIPPOL:** Internal Pre-charge Polarity bit⁽¹⁾
 1 = CHOLD is shorted to VREFH during pre-charge time
 0 = CHOLD is shorted to VREFL during pre-charge time
- bit 5-2 **Unimplemented:** Read as '0'
- bit 1 **ADxIPEN:** ADC Invert Polarity Enable bit
If ADxDSEN = 1:
 1 = The output value of the ADxEPPOL, ADxIPPOL, and GRDxPOL bits used by the ADC are inverted for the second conversion
 0 = The second ADC conversion proceeds like the first
If ADxDSEN = 0:
 This bit has no effect.
- bit 0 **ADxDSEN:** ADC Double Sample Enable bit
 1 = The ADC immediately starts a new conversion after completing a conversion. GO/DONEx bit is not automatically clear at end of conversion.
 0 = ADC operates in the traditional, single conversion mode

Note 1: When the ADxDSEN = 1 and ADxIPEN = 1; the polarity of this output is inverted for the second conversion time. The stored bit value does not change.

REGISTER 16-8: AADSTAT: HARDWARE CVD STATUS REGISTER

U-0	R/W-0/0	R/W-0/0	R/W-0/0	U-0	R/W-0/0	R/W-0/0	R/W-0/0
—	AD2CONV	AD2STG<1:0>		—	AD1CONV	AD1STG<1:0>	
bit 7				bit 0			

Legend:

R = Readable bit	W = Writable bit	U = Unimplemented bit, read as '0'
u = Bit is unchanged	x = Bit is unknown	-n/n = Value at POR and BOR/Value at all other Resets
'1' = Bit is set	'0' = Bit is cleared	

- bit 7 **Unimplemented:** Read as '0'
- bit 6 **AD2CONV:** ADC2 Conversion Status bit
 1 = Indicates ADC2 is in Conversion Sequence for AAD2RES1H:AAD2RES1L
 0 = Indicates ADC2 is in Conversion Sequence for AAD2RES0H:AAD2RES0L (Also reads '0' when $\overline{GO/DONE2} = 0$)
- bit 5-4 **AD2STG<1:0>:** ADC2 Stage Status bit
 11 = ADC2 module is in conversion stage
 10 = ADC2 module is in acquisition stage
 01 = ADC2 module is in pre-charge stage
 00 = ADC2 module is not converting (same as $\overline{GO/DONE2} = 0$)
- bit 3 **Unimplemented:** Read as '0'
- bit 2 **AD1CONV:** ADC1 Conversion Status bit
 1 = Indicates ADC1 is in Conversion Sequence for AAD1RES1H:AAD1RES1L
 0 = Indicates ADC1 is in Conversion Sequence for AAD1RES0H:AAD1RES0L (Also reads '0' when $\overline{GO/DONE1} = 0$)
- bit 1-0 **AD1STG<1:0>:** ADC1 Stage Status bit
 11 = ADC1 module is in conversion stage
 10 = ADC1 module is in acquisition stage
 01 = ADC1 module is in pre-charge stage
 00 = ADC1 module is not converting (same as $\overline{GO/DONE1} = 0$)

PIC16LF1554/1559

REGISTER 16-9: AADxPRE: HARDWARE CVD PRE-CHARGE CONTROL REGISTER

U-0	R/W-0/0	R/W-0/0	R/W-0/0	R/W-0/0	R/W-0/0	R/W-0/0	R/W-0/0
—	ADxPRE<6:0>						
bit 7							bit 0

Legend:

R = Readable bit	W = Writable bit	U = Unimplemented bit, read as '0'
u = Bit is unchanged	x = Bit is unknown	-n/n = Value at POR and BOR/Value at all other Resets
'1' = Bit is set	'0' = Bit is cleared	

bit 7 **Unimplemented:** Read as '0'

bit 6-0 **ADxPRE<6:0>:** Pre-charge Time Select bits⁽¹⁾

 111 1111 = Pre-charge for 127 instruction cycles

 111 1110 = Pre-charge for 126 instruction cycles

 .

 .

 .

 000 0001 = Pre-charge for 1 instruction cycle (Fosc/4)

 000 0000 = ADC pre-charge time is disabled

Note 1: When the FRC clock is selected as the conversion clock source, it is also the clock used for the pre-charge and acquisition times.

REGISTER 16-10: AADxACQ: HARDWARE CVD ACQUISITION TIME CONTROL REGISTER

U-0	R/W-0/0	R/W-0/0	R/W-0/0	R/W-0/0	R/W-0/0	R/W-0/0	R/W-0/0
—	AADxACQ<6:0>						
bit 7							bit 0

Legend:

R = Readable bit	W = Writable bit	U = Unimplemented bit, read as '0'
u = Bit is unchanged	x = Bit is unknown	-n/n = Value at POR and BOR/Value at all other Resets
'1' = Bit is set	'0' = Bit is cleared	

bit 7 **Unimplemented:** Read as '0'

bit 6-0 **AADxACQ<6:0>:** Acquisition/Charge Share Time Select bits⁽¹⁾

 111 1111 = Acquisition/charge share for 127 instruction cycles

 111 1110 = Acquisition/charge share for 126 instruction cycles

 .

 .

 .

 000 0001 = Acquisition/charge share for one instruction cycle (Fosc/4)

 000 0000 = ADC Acquisition/charge share time is disabled

Note 1: When the FRC clock is selected as the conversion clock source, it is also the clock used for the pre-charge and acquisition times.

REGISTER 16-11: AADxGRD: HARDWARE CVD GUARD RING CONTROL REGISTER

R/W-0/0	R/W-0/0	R/W-0/0	U-0	U-0	U-0	U-0	U-0
GRDxBOE ⁽²⁾	GRDxAOE ⁽²⁾	GRDxPOL ^(1,2)	—	—	—	—	—
bit 7							bit 0

Legend:

R = Readable bit

W = Writable bit

U = Unimplemented bit, read as '0'

u = Bit is unchanged

x = Bit is unknown

-n/n = Value at POR and BOR/Value at all other Resets

'1' = Bit is set

'0' = Bit is cleared

- bit 7 **GRDxBOE:** Guard Ring B Output Enable bit⁽²⁾
 1 = ADC guard ring output is enabled to ADxGRDB pin. Its corresponding TRISx bit must be clear.
 0 = No ADC guard ring function to this pin is enabled
- bit 6 **GRDxAOE:** Guard Ring A Output Enable bit⁽²⁾
 1 = ADC Guard Ring Output is enabled to ADxGRDA pin. Its corresponding TRISx, x bit must be clear.
 0 = No ADC Guard Ring function is enabled
- bit 5 **GRDxPOL:** Guard Ring Polarity Selection bit^(1,2)
 1 = ADCx guard ring outputs start as digital high during pre-charge stage
 0 = ADCx guard ring outputs start as digital low during pre-charge stage
- bit 4-0 **Unimplemented:** Read as '0'

- Note 1:** When the ADxDSEN = 1 and ADxIPEN = 1; the polarity of this output is inverted for the second conversion time. The stored bit value does not change.
- 2:** Guard Ring outputs are maintained while ADxCON = 1. The ADxGRDA output switches polarity at the start of the acquisition time.

PIC16LF1554/1559

REGISTER 16-12: AADxCAP: HARDWARE CVD ADDITIONAL SAMPLE CAPACITOR SELECTION REGISTER

U-0	U-0	U-0	U-0	R/W-0/0	R/W-0/0	R/W-0/0	R/W-0/0
—	—	—	—	ADDxCAP<3:0>			
bit 7				bit 0			

Legend:

R = Readable bit	W = Writable bit	U = Unimplemented bit, read as '0'
u = Bit is unchanged	x = Bit is unknown	-n/n = Value at POR and BOR/Value at all other Resets
'1' = Bit is set	'0' = Bit is cleared	

bit 7-4 **Unimplemented:** Read as '0'

bit 3-0 **ADDxCAP<3:0>:** ADC Additional Sample Capacitor Selection bits

- 1111 = Nominal Additional Sample Capacitor of 30pF
- 1110 = Nominal Additional Sample Capacitor of 28pF
- 1101 = Nominal Additional Sample Capacitor of 26pF
- 1100 = Nominal Additional Sample Capacitor of 24pF
- 1011 = Nominal Additional Sample Capacitor of 22pF
- 1010 = Nominal Additional Sample Capacitor of 20pF
- 1001 = Nominal Additional Sample Capacitor of 18pF
- 1000 = Nominal Additional Sample Capacitor of 16pF
- 0111 = Nominal Additional Sample Capacitor of 14pF
- 0110 = Nominal Additional Sample Capacitor of 12pF
- 0101 = Nominal Additional Sample Capacitor of 10pF
- 0100 = Nominal Additional Sample Capacitor of 8pF
- 0011 = Nominal Additional Sample Capacitor of 6pF
- 0010 = Nominal Additional Sample Capacitor of 4pF
- 0001 = Nominal Additional Sample Capacitor of 2pF
- 0000 = Additional Sample Capacitor is Disabled

REGISTER 16-13: AADxRESxH: HARDWARE CVD RESULT REGISTER MSB ADFM = 0⁽¹⁾

R/W-x/u	R/W-x/u	R/W-x/u	R/W-x/u	R/W-x/u	R/W-x/u	R/W-x/u	R/W-x/u
ADRESx<9:2>							
bit 7							bit 0

Legend:

R = Readable bit	W = Writable bit	U = Unimplemented bit, read as '0'
u = Bit is unchanged	x = Bit is unknown	-n/n = Value at POR and BOR/Value at all other Resets
'1' = Bit is set	'0' = Bit is cleared	

bit 7-0 **ADRESx<9:2>**: ADC Result Register bits
Upper eight bits of 10-bit conversion result

Note 1: See [Section 16.1.11 "Hardware CVD Register Mapping"](#) for more information.

REGISTER 16-14: AADxRESxL: HARDWARE CVD RESULT REGISTER LSL ADFM = 0⁽¹⁾

R/W-x/u	R/W-x/u	U-0	U-0	U-0	U-0	U-0	U-0
ADRESx<1:0>		—	—	—	—	—	—
bit 7							bit 0

Legend:

R = Readable bit	W = Writable bit	U = Unimplemented bit, read as '0'
u = Bit is unchanged	x = Bit is unknown	-n/n = Value at POR and BOR/Value at all other Resets
'1' = Bit is set	'0' = Bit is cleared	

bit 7-6 **ADRESx<1:0>**: ADC Result Register bits
Lower two bits of 10-bit conversion result

bit 5-0 **Reserved:** Do not use.

Note 1: See [Section 16.1.11 "Hardware CVD Register Mapping"](#) for more information.

PIC16LF1554/1559

REGISTER 16-15: AADxRESxH: HARDWARE CVD RESULT REGISTER MSB ADFM = 1⁽¹⁾

U-0	U-0	U-0	U-0	U-0	U-0	R/W-x/u	R/W-x/u
—	—	—	—	—	—	ADRESx<9:8>	
bit 7						bit 0	

Legend:

R = Readable bit	W = Writable bit	U = Unimplemented bit, read as '0'
u = Bit is unchanged	x = Bit is unknown	-n/n = Value at POR and BOR/Value at all other Resets
'1' = Bit is set	'0' = Bit is cleared	

bit 7-2 **Reserved:** Do not use.
bit 1-0 **ADRESx<9:8>:** ADC Result Register bits
Upper two bits of 10-bit conversion result

Note 1: See [Section 16.1.11 “Hardware CVD Register Mapping”](#) for more information.

REGISTER 16-16: AADxRESxL: HARDWARE CVD RESULT REGISTER LSB ADFM = 1⁽¹⁾

R/W-x/u	R/W-x/u	R/W-x/u	R/W-x/u	R/W-x/u	R/W-x/u	R/W-x/u	R/W-x/u
ADRESx<7:0>							
bit 7						bit 0	

Legend:

R = Readable bit	W = Writable bit	U = Unimplemented bit, read as '0'
u = Bit is unchanged	x = Bit is unknown	-n/n = Value at POR and BOR/Value at all other Resets
'1' = Bit is set	'0' = Bit is cleared	

bit 7-0 **ADRESx<7:0>:** ADC Result Register bits
Lower eight bits of 10-bit conversion result

Note 1: See [Section 16.1.11 “Hardware CVD Register Mapping”](#) for more information.

TABLE 16-2: SUMMARY OF REGISTERS ASSOCIATED WITH HARDWARE CVD

Name	Bit 7	Bit 6	Bit 5	Bit 4	Bit 3	Bit 2	Bit 1	Bit 0	Register on Page
AADxCAP	—	—	—	—	ADDxCAP<3:0>				160
AAD1CON0	—	CHS14	CHS13	CHS10	CHS11	CHS10	GO/DONE1	AD1ON	150
AAD2CON0	—	CHS24	CHS23	CHS20	CHS21	CHS20	GO/DONE2	AD2ON	151
AADCON1/ ADCOMCON	ADFM	ADCS<2:0>			—	GO/DONE_ALL	ADPREF<1:0>		154
AADxCON2	—	TRIGSELx<2:0>			—	—	—	—	155
AADxCON3	ADxEPPOL	ADxIPPOL	—	—	—	—	ADxIPEN	ADxDSEN	156
AADxGRD	GRDxBOE	GRDxAOE	GRDxPOL	—	—	—	—	—	159
AADxPRE	—	ADxPRE<6:0>							158
AADxRES0H	ADC Result 0 Register High								161
AADxRES0L	ADC Result 0 Register Low								161
AADxRES1H	ADC Result 1 Register High								162
AADxRES1L	ADC Result 1 Register Low								162
AADSTAT	—	AD2CONV	AD2STG<1:0>		—	AD1CONV	AD1STG<1:0>		157
AADxACQ	—	AADxACQ<6:0>							158
ANSELA	—	—	ANSA5	ANSA4	—	ANSA2	ANSA1	ANSA0	109
ANSELB	ANSB7	ANSB6	ANSB5	ANSB4	—	—	—	—	113
ANSELC	ANSC7	ANSC6	ANSC5	ANSC4	ANSC3	ANSC2	ANSC1	ANSC0	117
FVRCON	FVREN	FVRRDY	TSEN	TSRNG	—	—	ADFVR<1:0>		124
INTCON	GIE	PEIE	TMR0IE	INTE	IOCIE	TMR0IF	INTF	IOCIF	77
PIE1	TMR1GIE	AD1IE	RCIE	TXIE	SSP1IE	—	TMR2IE	TMR1IE	78
PIE2	—	AD2IE	—	—	BCLIE	—	—	—	79
PIR1	TMR1GIF	AD1IF	RCIF	TXIF	SSP1IF	—	TMR2IF	TMR1IF	80
PIR2	—	AD2IF	—	—	BCLIF	—	—	—	81
TRISA	—	—	TRISA5	TRISA4	— ⁽¹⁾	TRISA2	TRISA1	TRISA0	108
TRISB	TRISB7	TRISB6	TRISB5	TRISB4	—	—	—	—	112
TRISC	TRISC7	TRISC6	TRISC5	TRISC4	TRISC3	TRISC2	TRISC1	TRISC0	116

Legend: — = unimplemented read as '0'. Shaded cells are not used for hardware CVD module.

Note 1: Unimplemented, read as '1'.

PIC16LF1554/1559

17.0 TIMER0 MODULE

The Timer0 module is an 8-bit timer/counter with the following features:

- 8-bit timer/counter register (TMR0)
- 3-bit prescaler (independent of Watchdog Timer)
- Programmable internal or external clock source
- Programmable external clock edge selection
- Interrupt on overflow
- TMR0 can be used to gate Timer1

Figure 17-1 is a block diagram of the Timer0 module.

17.1 Timer0 Operation

The Timer0 module can be used as either an 8-bit timer or an 8-bit counter.

17.1.1 8-BIT TIMER MODE

The Timer0 module will increment every instruction cycle, if used without a prescaler. 8-bit Timer mode is selected by clearing the TMR0CS bit of the OPTION_REG register.

When TMR0 is written, the increment is inhibited for two instruction cycles immediately following the write.

Note: The value written to the TMR0 register can be adjusted, in order to account for the two instruction cycle delay when TMR0 is written.

17.1.2 8-BIT COUNTER MODE

In 8-Bit Counter mode, the Timer0 module will increment on every rising or falling edge of the T0CKI pin.

8-Bit Counter mode using the T0CKI pin is selected by setting the TMR0CS bit in the OPTION_REG register to '1'.

The rising or falling transition of the incrementing edge for either input source is determined by the TMR0SE bit in the OPTION_REG register.

FIGURE 17-1: TIMER0 BLOCK DIAGRAM

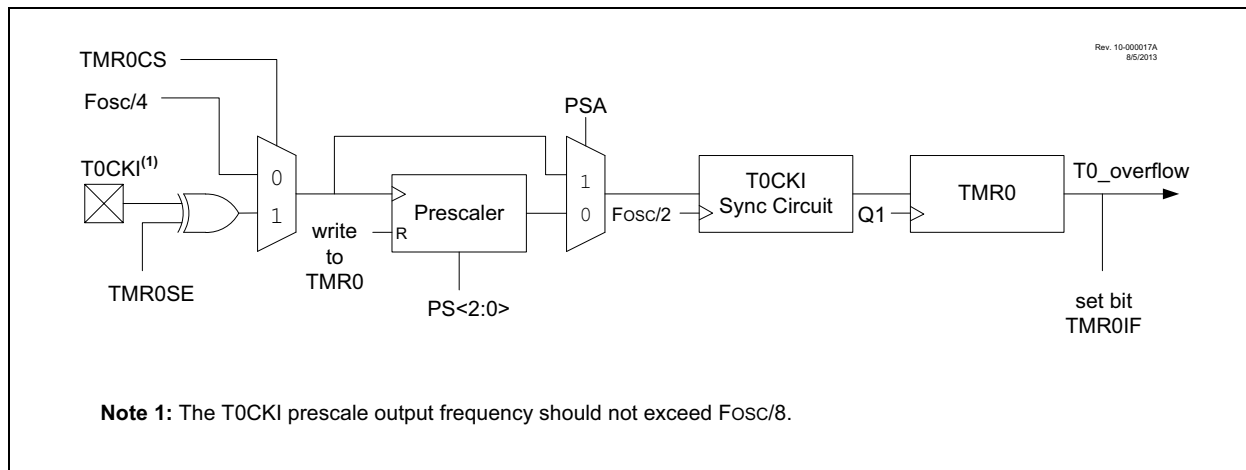

17.1.3 SOFTWARE PROGRAMMABLE PRESCALER

A software programmable prescaler is available for exclusive use with Timer0. The prescaler is enabled by clearing the PSA bit of the OPTION_REG register.

Note: The Watchdog Timer (WDT) uses its own independent prescaler.

There are eight prescaler options for the Timer0 module ranging from 1:2 to 1:256. The prescale values are selectable via the PS<2:0> bits of the OPTION_REG register. In order to have a 1:1 prescaler value for the Timer0 module, the prescaler must be disabled by setting the PSA bit of the OPTION_REG register.

The prescaler is not readable or writable. All instructions writing to the TMR0 register will clear the prescaler.

17.1.4 TIMER0 INTERRUPT

Timer0 will generate an interrupt when the TMR0 register overflows from FFh to 00h. The TMR0IF interrupt flag bit of the INTCON register is set every time the TMR0 register overflows, regardless of whether or not the Timer0 interrupt is enabled. The TMR0IF bit can only be cleared in software. The Timer0 interrupt enable is the TMR0IE bit of the INTCON register.

Note: The Timer0 interrupt cannot wake the processor from Sleep since the timer is frozen during Sleep.

17.1.5 8-BIT COUNTER MODE SYNCHRONIZATION

When in 8-Bit Counter mode, the incrementing edge on the T0CKI pin must be synchronized to the instruction clock. Synchronization can be accomplished by sampling the prescaler output on the Q2 and Q4 cycles of the instruction clock. The high and low periods of the external clocking source must meet the timing requirements as shown in [Section 25.0 “Electrical Specifications”](#).

17.1.6 OPERATION DURING SLEEP

Timer0 cannot operate while the processor is in Sleep mode. The contents of the TMR0 register will remain unchanged while the processor is in Sleep mode.

PIC16LF1554/1559

17.2 Register Definitions: Option Register

REGISTER 17-1: OPTION_REG: OPTION REGISTER

R/W-1/1	R/W-1/1	R/W-1/1	R/W-1/1	R/W-1/1	R/W-1/1	R/W-1/1	R/W-1/1
$\overline{\text{WPUEN}}$	INTEDG	TMR0CS	TMR0SE	PSA	PS<2:0>		
bit 7							bit 0

Legend:

R = Readable bit W = Writable bit U = Unimplemented bit, read as '0'
u = Bit is unchanged x = Bit is unknown -n/n = Value at POR and BOR/Value at all other Resets
'1' = Bit is set '0' = Bit is cleared

bit 7 **$\overline{\text{WPUEN}}$** : Weak Pull-Up Enable bit
1 = All weak pull-ups are disabled (except $\overline{\text{MCLR}}$, if it is enabled)
0 = Weak pull-ups are enabled by individual WPUx latch values

bit 6 **INTEDG**: Interrupt Edge Select bit
1 = Interrupt on rising edge of INT pin
0 = Interrupt on falling edge of INT pin

bit 5 **TMR0CS**: Timer0 Clock Source Select bit
1 = Transition on T0CKI pin
0 = Internal instruction cycle clock (Fosc/4)

bit 4 **TMR0SE**: Timer0 Source Edge Select bit
1 = Increment on high-to-low transition on T0CKI pin
0 = Increment on low-to-high transition on T0CKI pin

bit 3 **PSA**: Prescaler Assignment bit
1 = Prescaler is not assigned to the Timer0 module
0 = Prescaler is assigned to the Timer0 module

bit 2-0 **PS<2:0>**: Prescaler Rate Select bits

Bit Value	Timer0 Rate
000	1 : 2
001	1 : 4
010	1 : 8
011	1 : 16
100	1 : 32
101	1 : 64
110	1 : 128
111	1 : 256

TABLE 17-1: SUMMARY OF REGISTERS ASSOCIATED WITH TIMERO

Name	Bit 7	Bit 6	Bit 5	Bit 4	Bit 3	Bit 2	Bit 1	Bit 0	Register on Page
ADxCON2	—	TRIGSELx<2:0>			—	—	—	—	136
INTCON	GIE	PEIE	TMR0IE	INTE	IOCIE	TMR0IF	INTF	IOCIF	77
OPTION_REG	$\overline{\text{WPUEN}}$	INTEDG	TMR0CS	TMR0SE	PSA	PS<2:0>			166
TMR0	Holding Register for the 8-bit Timer0 Count								164*
TRISA	—	—	TRISA5	TRISA4	— ⁽¹⁾	TRISA2	TRISA1	TRISA0	108

Legend: — = Unimplemented location, read as '0'. Shaded cells are not used by the Timer0 module.

* Page provides register information.

Note 1: Unimplemented, read as '1'.

18.0 TIMER1 MODULE WITH GATE CONTROL

The Timer1 module is a 16-bit timer/counter with the following features:

- 16-bit timer/counter register pair (TMR1H:TMR1L)
- Programmable internal or external clock source
- 2-bit prescaler
- Optionally synchronized comparator out
- Multiple Timer1 gate (count enable) sources

- Interrupt on overflow
- Wake-up on overflow (external clock, Asynchronous mode only)
- ADC Auto-Conversion Trigger(s)
- Selectable Gate Source Polarity
- Gate Toggle mode
- Gate Single-Pulse mode
- Gate Value Status
- Gate Event Interrupt

Figure 18-1 is a block diagram of the Timer1 module.

FIGURE 18-1: TIMER1 BLOCK DIAGRAM

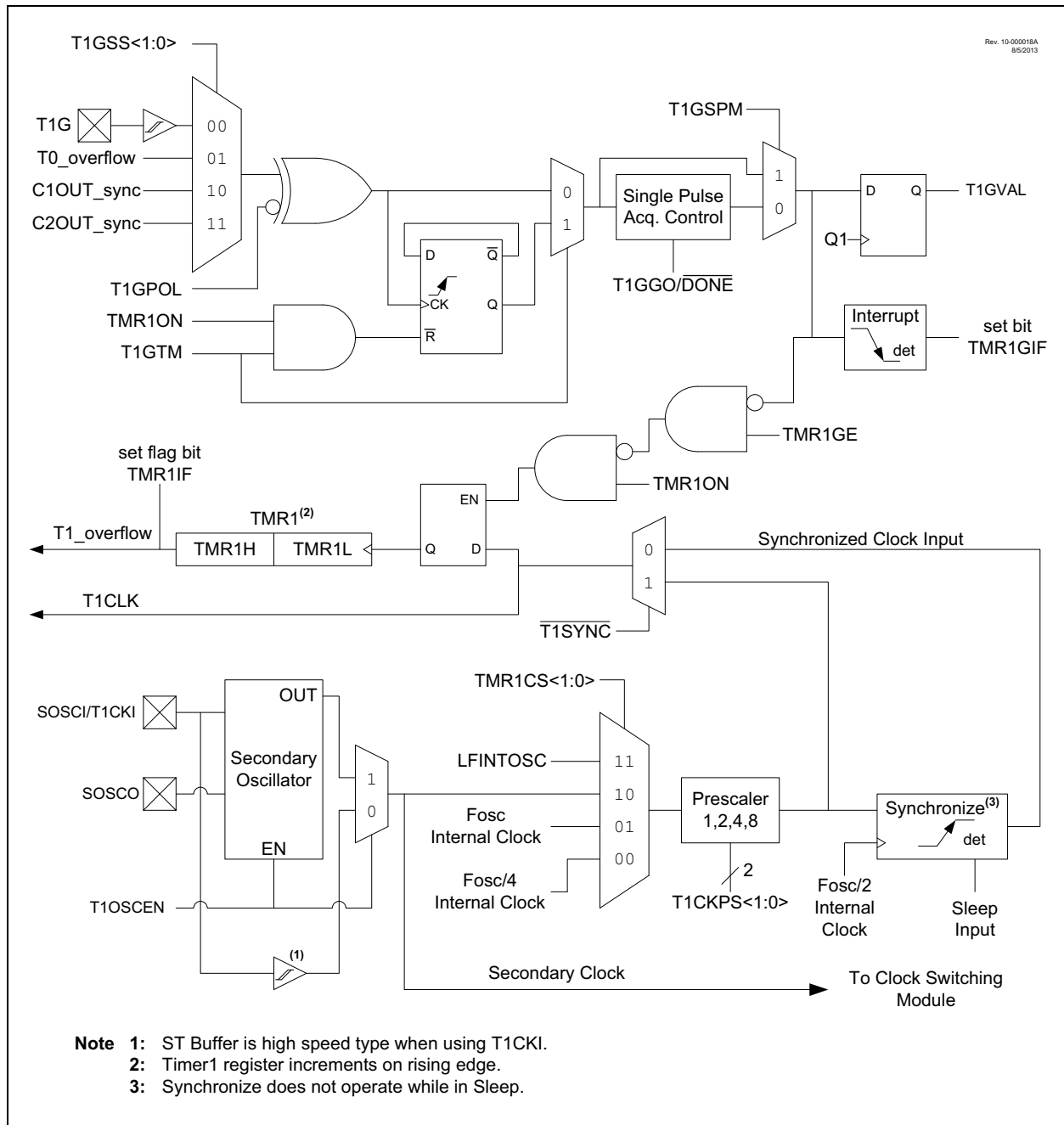

PIC16LF1554/1559

18.1 Timer1 Operation

The Timer1 module is a 16-bit incrementing counter which is accessed through the TMR1H:TMR1L register pair. Writes to TMR1H or TMR1L directly update the counter.

When used with an internal clock source, the module is a timer and increments on every instruction cycle. When used with an external clock source, the module can be used as either a timer or counter and increments on every selected edge of the external source.

Timer1 is enabled by configuring the TMR1ON and TMR1GE bits in the T1CON and T1GCON registers, respectively. Table 18-1 displays the Timer1 enable selections.

TABLE 18-1: TIMER1 ENABLE SELECTIONS

TMR1ON	TMR1GE	Timer1 Operation
0	0	Off
0	1	Off
1	0	Always On
1	1	Count Enabled

18.2 Clock Source Selection

The TMR1CS<1:0> bits of the T1CON register are used to select the clock source for Timer1. Table 18-2 displays the clock source selections.

18.2.1 INTERNAL CLOCK SOURCE

When the internal clock source is selected, the TMR1H:TMR1L register pair will increment on multiples of FOSC as determined by the Timer1 prescaler.

When the Fosc internal clock source is selected, the Timer1 register value will increment by four counts every instruction clock cycle. Due to this condition, a 2 LSB error in resolution will occur when reading the Timer1 value. To utilize the full resolution of Timer1, an asynchronous input signal must be used to gate the Timer1 clock input.

The following asynchronous sources may be used:

- Asynchronous event on the T1G pin to Timer1 gate
- C1 or C2 comparator input to Timer1 gate

18.2.2 EXTERNAL CLOCK SOURCE

When the external clock source is selected, the Timer1 module may work as a timer or a counter.

When enabled to count, Timer1 is incremented on the rising edge of the external clock input T1CKI. The external clock source can be synchronized to the microcontroller system clock or it can run asynchronously.

Note: In Counter mode, a falling edge must be registered by the counter prior to the first incrementing rising edge after any one or more of the following conditions:

- Timer1 enabled after POR
- Write to TMR1H or TMR1L
- Timer1 is disabled
- Timer1 is disabled (TMR1ON = 0) when T1CKI is high then Timer1 is enabled (TMR1ON=1) when T1CKI is low.

TABLE 18-2: CLOCK SOURCE SELECTIONS

TMR1CS<1:0>	Clock Source
11	LFINTOSC
10	External Clocking on T1CKI Pin
01	System Clock (FOSC)
00	Instruction Clock (FOSC/4)

18.3 Timer1 Prescaler

Timer1 has four prescaler options allowing 1, 2, 4 or 8 divisions of the clock input. The T1CKPS bits of the T1CON register control the prescale counter. The prescale counter is not directly readable or writable; however, the prescaler counter is cleared upon a write to TMR1H or TMR1L.

18.4 Timer1 Operation in Asynchronous Counter Mode

If control bit $\overline{T1SYNC}$ of the T1CON register is set, the external clock input is not synchronized. The timer increments asynchronously to the internal phase clocks. If the external clock source is selected then the timer will continue to run during Sleep and can generate an interrupt on overflow, which will wake-up the processor. However, special precautions in software are needed to read/write the timer (see [Section 18.4.1 “Reading and Writing Timer1 in Asynchronous Counter Mode”](#)).

Note: When switching from synchronous to asynchronous operation, it is possible to skip an increment. When switching from asynchronous to synchronous operation, it is possible to produce an additional increment.

18.4.1 READING AND WRITING TIMER1 IN ASYNCHRONOUS COUNTER MODE

Reading TMR1H or TMR1L while the timer is running from an external asynchronous clock will ensure a valid read (taken care of in hardware). However, the user should keep in mind that reading the 16-bit timer in two 8-bit values itself, poses certain problems, since the timer may overflow between the reads.

For writes, it is recommended that the user simply stop the timer and write the desired values. A write contention may occur by writing to the timer registers, while the register is incrementing. This may produce an unpredictable value in the TMR1H:TMR1L register pair.

18.5 Timer1 Gate

Timer1 can be configured to count freely or the count can be enabled and disabled using Timer1 gate circuitry. This is also referred to as Timer1 Gate Enable.

Timer1 gate can also be driven by multiple selectable sources.

18.5.1 TIMER1 GATE ENABLE

The Timer1 Gate Enable mode is enabled by setting the TMR1GE bit of the T1GCON register. The polarity of the Timer1 Gate Enable mode is configured using the T1GPOL bit of the T1GCON register.

When Timer1 Gate Enable mode is enabled, Timer1 will increment on the rising edge of the Timer1 clock source. When Timer1 Gate Enable mode is disabled, no incrementing will occur and Timer1 will hold the current count. See [Figure 18-3](#) for timing details.

TABLE 18-3: TIMER1 GATE ENABLE SELECTIONS

T1CLK	T1GPOL	T1G	Timer1 Operation
↑	0	0	Counts
↑	0	1	Holds Count
↑	1	0	Holds Count
↑	1	1	Counts

18.5.2 TIMER1 GATE SOURCE SELECTION

Timer1 gate source selections are shown in [Table 18-4](#). Source selection is controlled by the T1GSS bit of the T1GCON register. The polarity for each available source is also selectable. Polarity selection is controlled by the T1GPOL bit of the T1GCON register.

TABLE 18-4: TIMER1 GATE SOURCES

T1GSS	Timer1 Gate Source
0	Timer1 Gate pin (T1G)
1	Overflow of Timer0 (T0_overflow) (TMR0 increments from FFh to 00h)

PIC16LF1554/1559

18.5.2.1 T1G Pin Gate Operation

The T1G pin is one source for Timer1 gate control. It can be used to supply an external source to the Timer1 gate circuitry.

18.5.2.2 Timer0 Overflow Gate Operation

When Timer0 increments from FFh to 00h, a low-to-high pulse will automatically be generated and internally supplied to the Timer1 gate circuitry.

18.5.3 TIMER1 GATE TOGGLE MODE

When Timer1 Gate Toggle mode is enabled, it is possible to measure the full-cycle length of a Timer1 gate signal, as opposed to the duration of a single level pulse.

The Timer1 gate source is routed through a flip-flop that changes state on every incrementing edge of the signal. See [Figure 18-4](#) for timing details.

Timer1 Gate Toggle mode is enabled by setting the T1GTM bit of the T1GCON register. When the T1GTM bit is cleared, the flip-flop is cleared and held clear. This is necessary in order to control which edge is measured.

Note: Enabling Toggle mode at the same time as changing the gate polarity may result in indeterminate operation.

18.5.4 TIMER1 GATE SINGLE-PULSE MODE

When Timer1 Gate Single-Pulse mode is enabled, it is possible to capture a single pulse gate event. Timer1 Gate Single-Pulse mode is first enabled by setting the T1GSPM bit in the T1GCON register. Next, the T1GGO/DONE bit in the T1GCON register must be set. The Timer1 will be fully enabled on the next incrementing edge. On the next trailing edge of the pulse, the T1GGO/DONE bit will automatically be cleared. No other gate events will be allowed to increment Timer1 until the T1GGO/DONE bit is once again set in software. See [Figure 18-5](#) for timing details.

If the Single Pulse Gate mode is disabled by clearing the T1GSPM bit in the T1GCON register, the T1GGO/DONE bit should also be cleared.

Enabling the Toggle mode and the Single-Pulse mode simultaneously will permit both sections to work together. This allows the cycle times on the Timer1 gate source to be measured. See [Figure 18-6](#) for timing details.

18.5.5 TIMER1 GATE VALUE STATUS

When Timer1 Gate Value Status is utilized, it is possible to read the most current level of the gate control value. The value is stored in the T1GVAL bit in the T1GCON register. The T1GVAL bit is valid even when the Timer1 gate is not enabled (TMR1GE bit is cleared).

18.5.6 TIMER1 GATE EVENT INTERRUPT

When Timer1 Gate Event Interrupt is enabled, it is possible to generate an interrupt upon the completion of a gate event. When the falling edge of T1GVAL occurs, the TMR1GIF flag bit in the PIR1 register will be set. If the TMR1GIE bit in the PIE1 register is set, then an interrupt will be recognized.

The TMR1GIF flag bit operates even when the Timer1 gate is not enabled (TMR1GE bit is cleared).

18.6 Timer1 Interrupt

The Timer1 register pair (TMR1H:TMR1L) increments to FFFFh and rolls over to 0000h. When Timer1 rolls over, the Timer1 interrupt flag bit of the PIR1 register is set. To enable the interrupt on rollover, you must set these bits:

- TMR1ON bit of the T1CON register
- TMR1IE bit of the PIE1 register
- PEIE bit of the INTCON register
- GIE bit of the INTCON register

The interrupt is cleared by clearing the TMR1IF bit in the Interrupt Service Routine.

Note: The TMR1H:TMR1L register pair and the TMR1IF bit should be cleared before enabling interrupts.

18.7 Timer1 Operation During Sleep

Timer1 can only operate during Sleep when setup in Asynchronous Counter mode. In this mode, an external crystal or clock source can be used to increment the counter. To set up the timer to wake the device:

- TMR1ON bit of the T1CON register must be set
- TMR1IE bit of the PIE1 register must be set
- PEIE bit of the INTCON register must be set
- T1SYNC bit of the T1CON register must be set
- TMR1CS bits of the T1CON register must be configured

The device will wake-up on an overflow and execute the next instructions. If the GIE bit of the INTCON register is set, the device will call the Interrupt Service Routine.

Timer1 oscillator will continue to operate in Sleep regardless of the T1SYNC bit setting.

18.7.1 ALTERNATE PIN LOCATIONS

This module incorporates I/O pins that can be moved to other locations with the use of the alternate pin function register, APFCON. To determine which pins can be moved and what their default locations are upon a Reset, see [Section 11.1 “Alternate Pin Function”](#) for more information.

FIGURE 18-2: TIMER1 INCREMENTING EDGE

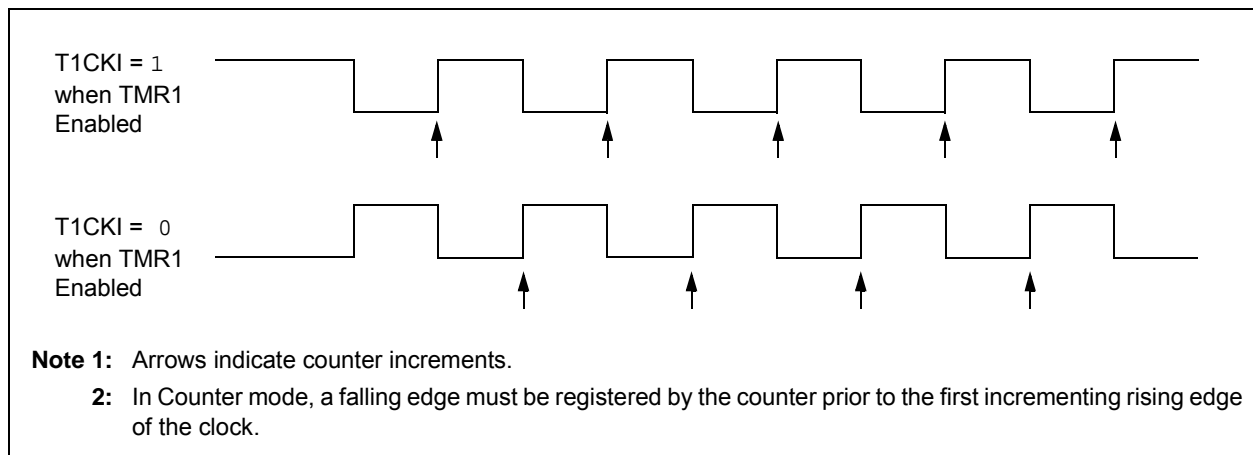

PIC16LF1554/1559

FIGURE 18-3: TIMER1 GATE ENABLE MODE

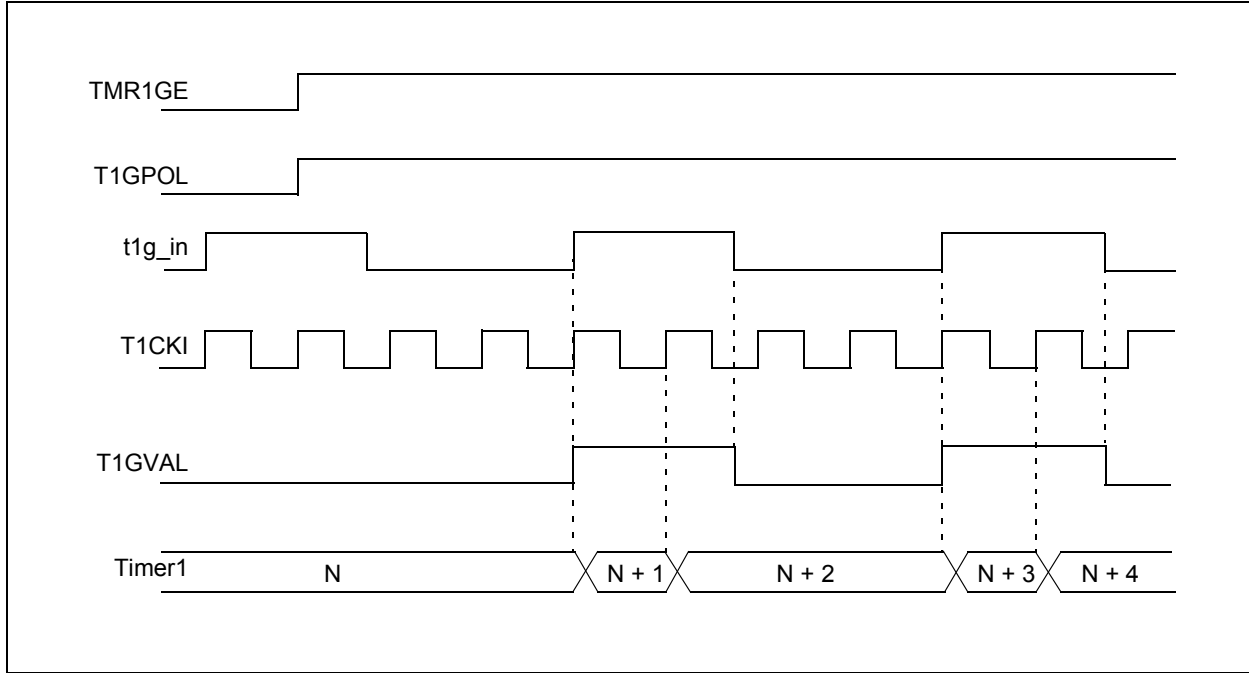

FIGURE 18-4: TIMER1 GATE TOGGLE MODE

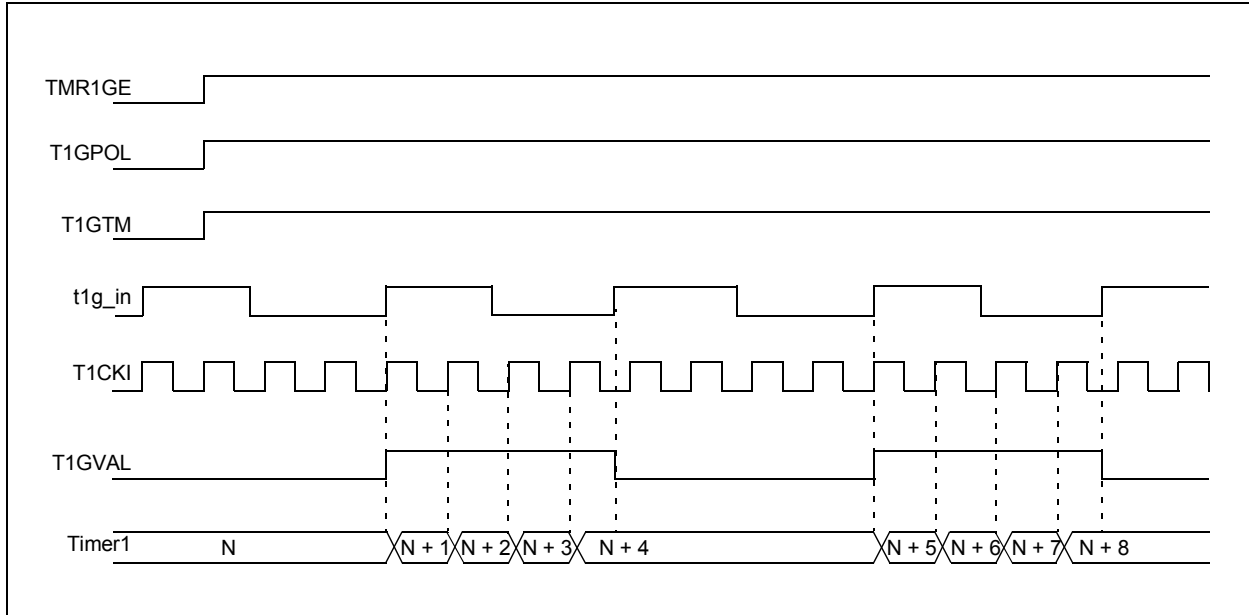
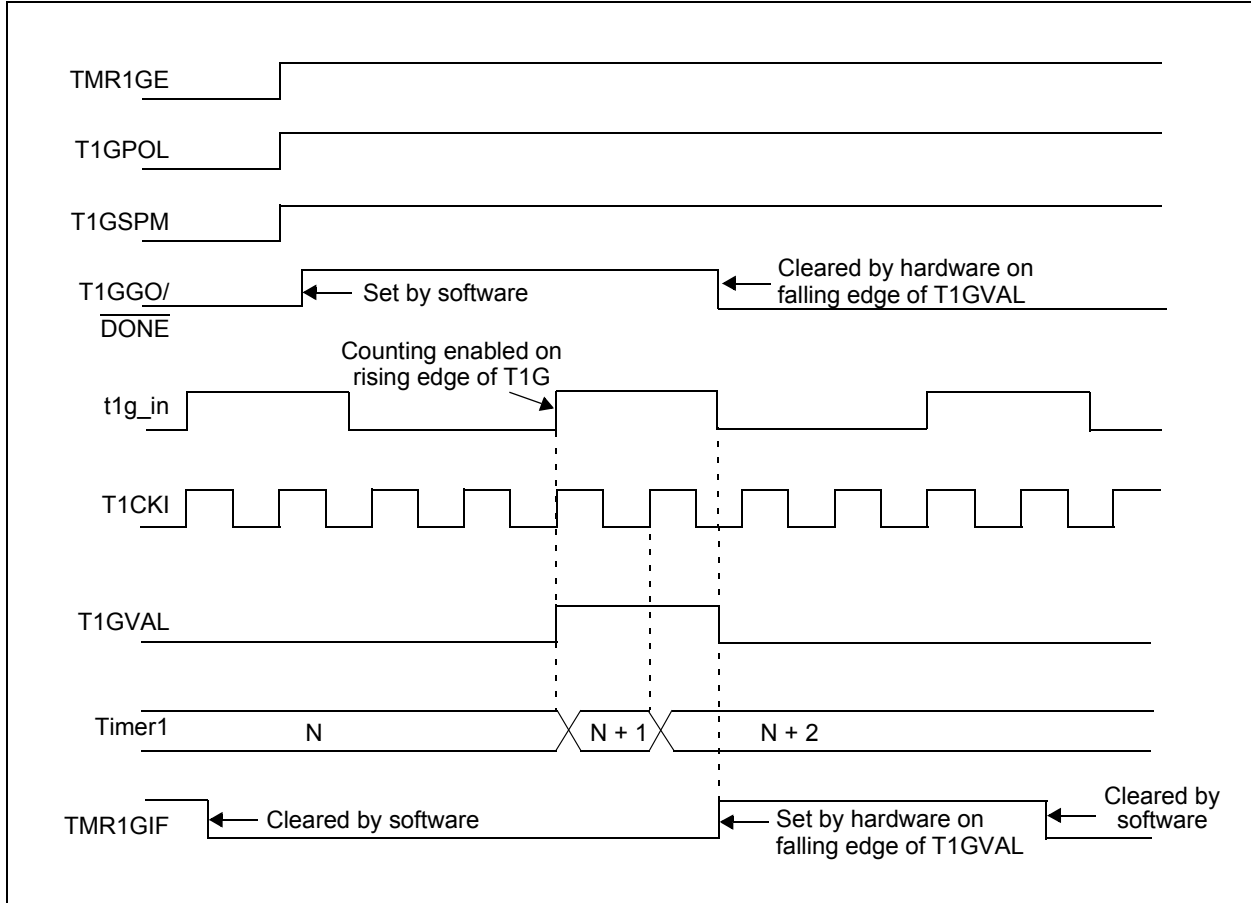
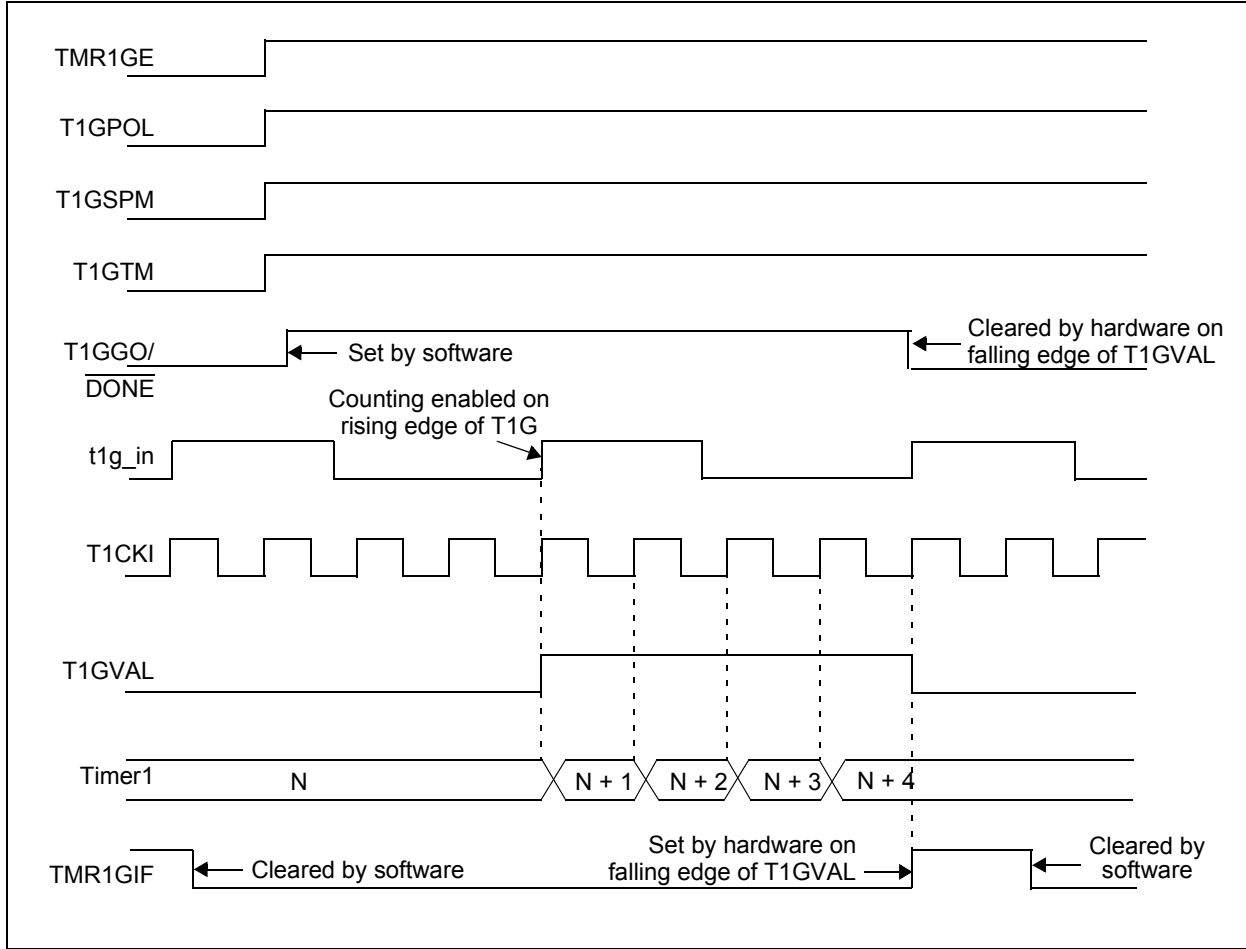

FIGURE 18-5: TIMER1 GATE SINGLE-PULSE MODE



PIC16LF1554/1559

FIGURE 18-6: TIMER1 GATE SINGLE-PULSE AND TOGGLE COMBINED MODE



18.8 Register Definitions: Timer1 Control

REGISTER 18-1: T1CON: TIMER1 CONTROL REGISTER

R/W-0/u	R/W-0/u	R/W-0/u	R/W-0/u	U-0	R/W-0/u	U-0	R/W-0/u
TMR1CS<1:0>		T1CKPS<1:0>		—	$\overline{\text{T1SYNC}}$	—	TMR1ON
bit 7							bit 0

Legend:

R = Readable bit	W = Writable bit	U = Unimplemented bit, read as '0'
u = Bit is unchanged	x = Bit is unknown	-n/n = Value at POR and BOR/Value at all other Resets
'1' = Bit is set	'0' = Bit is cleared	

- bit 7-6 **TMR1CS<1:0>**: Timer1 Clock Source Select bits
 11 = Timer1 clock source is LFINTOSC
 10 = Timer1 clock source is external clock from T1CKI pin (on the rising edge)
 01 = Timer1 clock source is system clock (Fosc)
 00 = Timer1 clock source is instruction clock (Fosc/4)
- bit 5-4 **T1CKPS<1:0>**: Timer1 Input Clock Prescale Select bits
 11 = 1:8 Prescale value
 10 = 1:4 Prescale value
 01 = 1:2 Prescale value
 00 = 1:1 Prescale value
- bit 3 **Unimplemented**: Read as '0'
- bit 2 **T1SYNC**: Timer1 Synchronization Control bit
 1 = Do not synchronize asynchronous clock input
 0 = Synchronize asynchronous clock input with system clock (Fosc)
- bit 1 **Unimplemented**: Read as '0'
- bit 0 **TMR1ON**: Timer1 On bit
 1 = Enables Timer1
 0 = Stops Timer1 and clears Timer1 gate flip-flop

PIC16LF1554/1559

REGISTER 18-2: T1GCON: TIMER1 GATE CONTROL REGISTER

R/W-0/u	R/W-0/u	R/W-0/u	R/W-0/u	R/W/HC-0/u	R-x/x	U-0	R/W-0/u
TMR1GE	T1GPOL	T1GTM	T1GSPM	T1GGO/DONE	T1GVAL	—	T1GSS
bit 7							bit 0

Legend:

R = Readable bit	W = Writable bit	U = Unimplemented bit, read as '0'
u = Bit is unchanged	x = Bit is unknown	-n/n = Value at POR and BOR/Value at all other Resets
'1' = Bit is set	'0' = Bit is cleared	HC = Bit is cleared by hardware

bit 7 **TMR1GE:** Timer1 Gate Enable bit

If TMR1ON = 0:

This bit is ignored

If TMR1ON = 1:

1 = Timer1 counting is controlled by the Timer1 gate function

0 = Timer1 counts regardless of Timer1 gate function

bit 6 **T1GPOL:** Timer1 Gate Polarity bit

1 = Timer1 gate is active-high (Timer1 counts when gate is high)

0 = Timer1 gate is active-low (Timer1 counts when gate is low)

bit 5 **T1GTM:** Timer1 Gate Toggle Mode bit

1 = Timer1 Gate Toggle mode is enabled

0 = Timer1 Gate Toggle mode is disabled and toggle flip-flop is cleared

Timer1 gate flip-flop toggles on every rising edge.

bit 4 **T1GSPM:** Timer1 Gate Single-Pulse Mode bit

1 = Timer1 gate Single-Pulse mode is enabled and is controlling Timer1 gate

0 = Timer1 gate Single-Pulse mode is disabled

bit 3 **T1GGO/DONE:** Timer1 Gate Single-Pulse Acquisition Status bit

1 = Timer1 gate single-pulse acquisition is ready, waiting for an edge

0 = Timer1 gate single-pulse acquisition has completed or has not been started

bit 2 **T1GVAL:** Timer1 Gate Value Status bit

Indicates the current state of the Timer1 gate that could be provided to TMR1H:TMR1L.

Unaffected by Timer1 Gate Enable (TMR1GE).

bit 1 **Unimplemented:** Read as '0'

bit 0 **T1GSS:** Timer1 Gate Source Select bits

01 = Timer0 overflow output (T0_overflow)

00 = Timer1 gate pin (T1G)

TABLE 18-5: SUMMARY OF REGISTERS ASSOCIATED WITH TIMER1

Name	Bit 7	Bit 6	Bit 5	Bit 4	Bit 3	Bit 2	Bit 1	Bit 0	Register on Page
ANSELA	—	—	ANSA5	ANSA4	—	ANSA2	ANSA1	ANSA0	109
APFCON	RXDTSEL	SDOSEL	SSSEL	SDSEL	—	TXCKSEL	GRDBSEL	GRDASEL	106
INTCON	GIE	PEIE	TMR0IE	INTE	IOCIE	TMR0IF	INTF	IOCIF	77
OSCSTAT	—	PLLSR	—	HFIOFR	—	—	LFIOFR	HFIOFS	63
PIE1	TMR1GIE	AD1IE	RCIE	TXIE	SSP1IE	—	TMR2IE	TMR1IE	78
PIR1	TMR1GIF	AD1IF	RCIF	TXIF	SSP1IF	—	TMR2IF	TMR1IF	80
TMR1H	Holding Register for the Most Significant Byte of the 16-bit TMR1 Count								171*
TMR1L	Holding Register for the Least Significant Byte of the 16-bit TMR1 Count								171*
TRISA	—	—	TRISA5	TRISA4	— ⁽¹⁾	TRISA2	TRISA1	TRISA0	108
T1CON	TMR1CS<1:0>		T1CKPS<1:0>		—	$\overline{T1SYNC}$	—	TMR1ON	175
T1GCON	TMR1GE	T1GPOL	T1GTM	T1GSPM	T1GGO/ DONE	T1GVAL	—	T1GSS	176

Legend: — = unimplemented location, read as '0'. Shaded cells are not used by the Timer1 module.

* Page provides register information.

Note 1: Unimplemented, read as '1'.

PIC16LF1554/1559

19.0 TIMER2 MODULE

The Timer2 module incorporates the following features:

- 8-bit Timer and Period registers (TMR2 and PR2, respectively)
- Readable and writable (both registers)
- Software programmable prescaler (1:1, 1:4, 1:16, and 1:64)
- Software programmable postscaler (1:1 to 1:16)
- Interrupt on TMR2 match with PR2

See [Figure 19-1](#) for a block diagram of Timer2.

FIGURE 19-1: TIMER2 BLOCK DIAGRAM

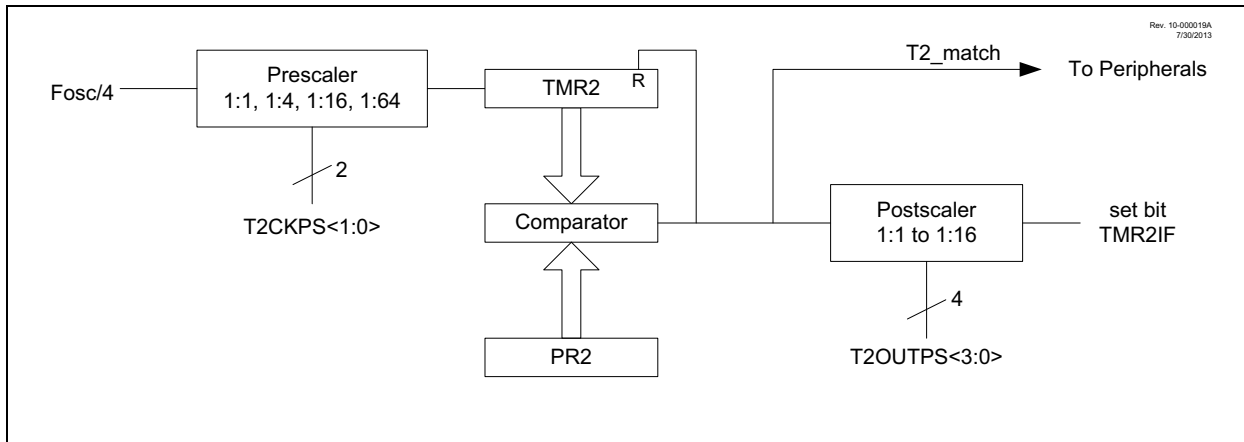
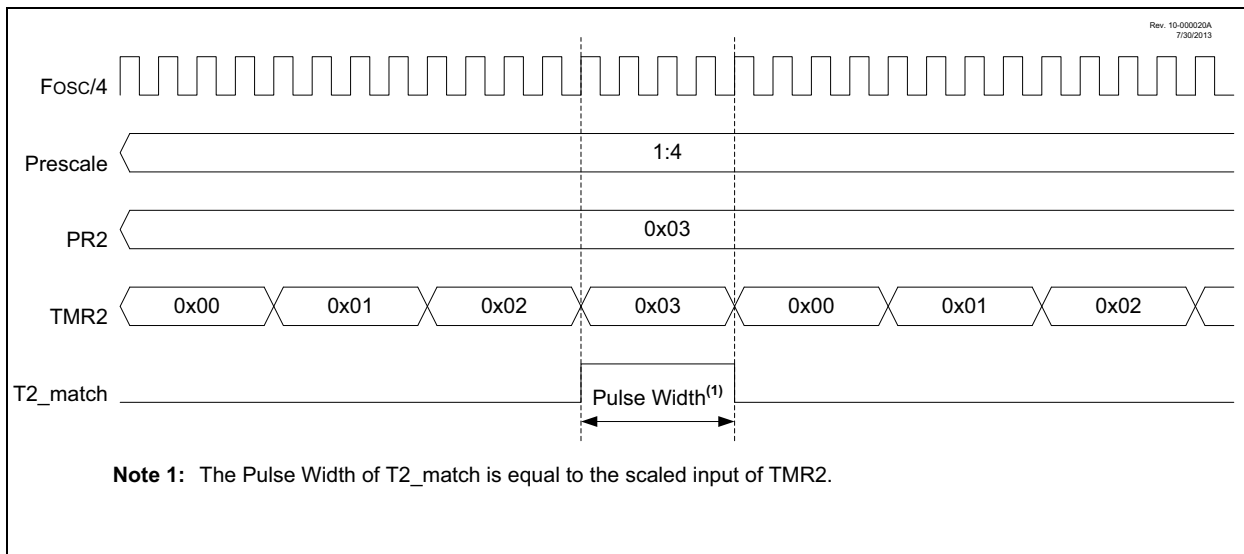

FIGURE 19-2: TIMER2 TIMING DIAGRAM



19.1 Timer2 Operation

The clock input to the Timer2 module is the system instruction clock ($F_{osc}/4$).

TMR2 increments from 00h on each clock edge.

A 4-bit counter/prescaler on the clock input allows direct input, divide-by-4 and divide-by-16 prescale options. These options are selected by the prescaler control bits, $T2CKPS<1:0>$ of the T2CON register. The value of TMR2 is compared to that of the Period register, PR2, on each clock cycle. When the two values match, the comparator generates a match signal as the timer output. This signal also resets the value of TMR2 to 00h on the next cycle and drives the output counter/postscaler (see [Section 19.2 “Timer2 Interrupt”](#)).

The TMR2 and PR2 registers are both directly readable and writable. The TMR2 register is cleared on any device Reset, whereas the PR2 register initializes to FFh. Both the prescaler and postscaler counters are cleared on the following events:

- a write to the TMR2 register
- a write to the T2CON register
- Power-On Reset (POR)
- Brown-Out Reset (BOR)
- MCLR Reset
- Watchdog Timer (WDT) Reset
- Stack Overflow Reset
- Stack Underflow Reset
- RESET Instruction

Note: TMR2 is not cleared when T2CON is written.

19.2 Timer2 Interrupt

Timer2 can also generate an optional device interrupt. The Timer2 output signal (T2_match) provides the input for the 4-bit counter/postscaler. This counter generates the TMR2 match interrupt flag which is latched in TMR2IF of the PIR1 register. The interrupt is enabled by setting the TMR2 Match Interrupt Enable bit, TMR2IE of the PIE1 register.

A range of 16 postscale options (from 1:1 through 1:16 inclusive) can be selected with the postscaler control bits, $T2OUTPS<3:0>$, of the T2CON register.

19.3 Timer2 Output

The output of TMR2 is T2_match. T2_match is available to the following peripherals:

- Configurable Logic Cell (CLC)
- Master Synchronous Serial Port (MSSP)
- Numerically Controlled Oscillator (NCO)
- Pulse Width Modulator (PWM)

The T2_match signal is synchronous with the system clock. [Figure 19-3](#) shows two examples of the timing of the T2_match signal relative to F_{osc} and prescale value, $T2CKPS<1:0>$. The upper diagram illustrates 1:1 prescale timing and the lower diagram, 1:X prescale timing.

FIGURE 19-3: T2_MATCH TIMING DIAGRAM

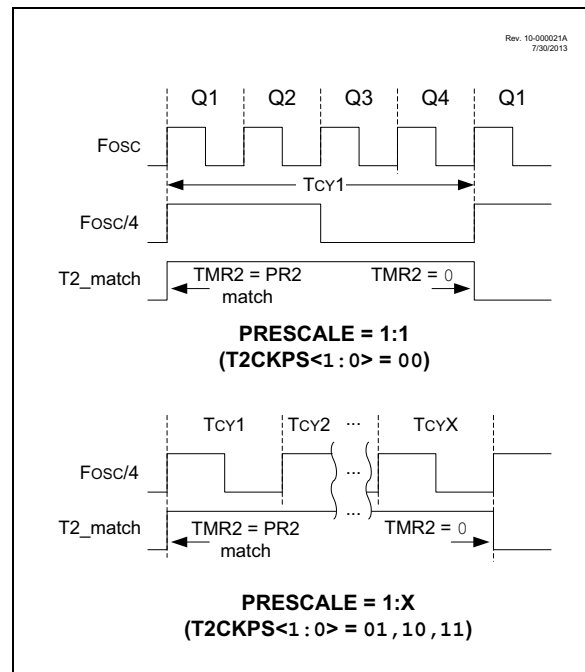

19.4 Timer2 Operation During Sleep

Timer2 cannot be operated while the processor is in Sleep mode. The contents of the TMR2 and PR2 registers will remain unchanged while the processor is in Sleep mode.

PIC16LF1554/1559

19.5 Register Definitions: Timer2 Control

REGISTER 19-1: T2CON: TIMER2 CONTROL REGISTER

U-0	R/W-0/0	R/W-0/0	R/W-0/0	R/W-0/0	R/W-0/0	R/W-0/0	R/W-0/0
—	T2OUTPS<3:0>				TMR2ON	T2CKPS<1:0>	
bit 7							bit 0

Legend:

R = Readable bit W = Writable bit U = Unimplemented bit, read as '0'
u = Bit is unchanged x = Bit is unknown -n/n = Value at POR and BOR/Value at all other Resets
'1' = Bit is set '0' = Bit is cleared

- bit 7 **Unimplemented:** Read as '0'
- bit 6-3 **T2OUTPS<3:0>:** Timer2 Output Postscaler Select bits
0000 = 1:1 Postscaler
0001 = 1:2 Postscaler
0010 = 1:3 Postscaler
0011 = 1:4 Postscaler
0100 = 1:5 Postscaler
0101 = 1:6 Postscaler
0110 = 1:7 Postscaler
0111 = 1:8 Postscaler
1000 = 1:9 Postscaler
1001 = 1:10 Postscaler
1010 = 1:11 Postscaler
1011 = 1:12 Postscaler
1100 = 1:13 Postscaler
1101 = 1:14 Postscaler
1110 = 1:15 Postscaler
1111 = 1:16 Postscaler
- bit 2 **TMR2ON:** Timer2 On bit
1 = Timer2 is on
0 = Timer2 is off
- bit 1-0 **T2CKPS<1:0>:** Timer2 Clock Prescale Select bits
00 = Prescaler is 1
01 = Prescaler is 4
10 = Prescaler is 16
11 = Prescaler is 64

TABLE 19-1: SUMMARY OF REGISTERS ASSOCIATED WITH TIMER2

Name	Bit 7	Bit 6	Bit 5	Bit 4	Bit 3	Bit 2	Bit 1	Bit 0	Register on Page
INTCON	GIE	PEIE	TMR0IE	INTE	IOCIE	TMR0IF	INTF	IOCIF	77
PIE1	TMR1GIE	AD1IE	RCIE	TXIE	SSP1IE	—	TMR2IE	TMR1IE	78
PIR1	TMR1GIF	AD1IF	RCIF	TXIF	SSP1IF	—	TMR2IF	TMR1IF	80
PR2	Timer2 Module Period Register								178*
T2CON	—	T2OUTPS<3:0>				TMR2ON	T2CKPS<1:0>		180
TMR2	Holding Register for the 8-bit TMR2 Count								178*

Legend: — = unimplemented location, read as '0'. Shaded cells are not used for Timer2 module.

* Page provides register information.

20.0 MASTER SYNCHRONOUS SERIAL PORT (MSSP) MODULE

Note: Register names, I/O pins, and bit names may use the generic designator 'x' to indicate the use of a numeral to distinguish a particular module, when required.

20.1 MSSP Module Overview

The Master Synchronous Serial Port (MSSP) module is a serial interface useful for communicating with other peripheral or microcontroller devices. These peripheral devices may be Serial EEPROMs, shift registers, display drivers, ADC converters, etc. The MSSP module can operate in one of two modes:

- Serial Peripheral Interface (SPI)
- Inter-Integrated Circuit™ (I²C™)

The SPI interface supports the following modes and features:

- Master mode
- Slave mode
- Clock Parity
- Slave Select Synchronization (Slave mode only)
- Daisy-chain connection of slave devices

Figure 20-1 is a block diagram of the SPI interface module.

FIGURE 20-1: MSSP BLOCK DIAGRAM (SPI MODE)

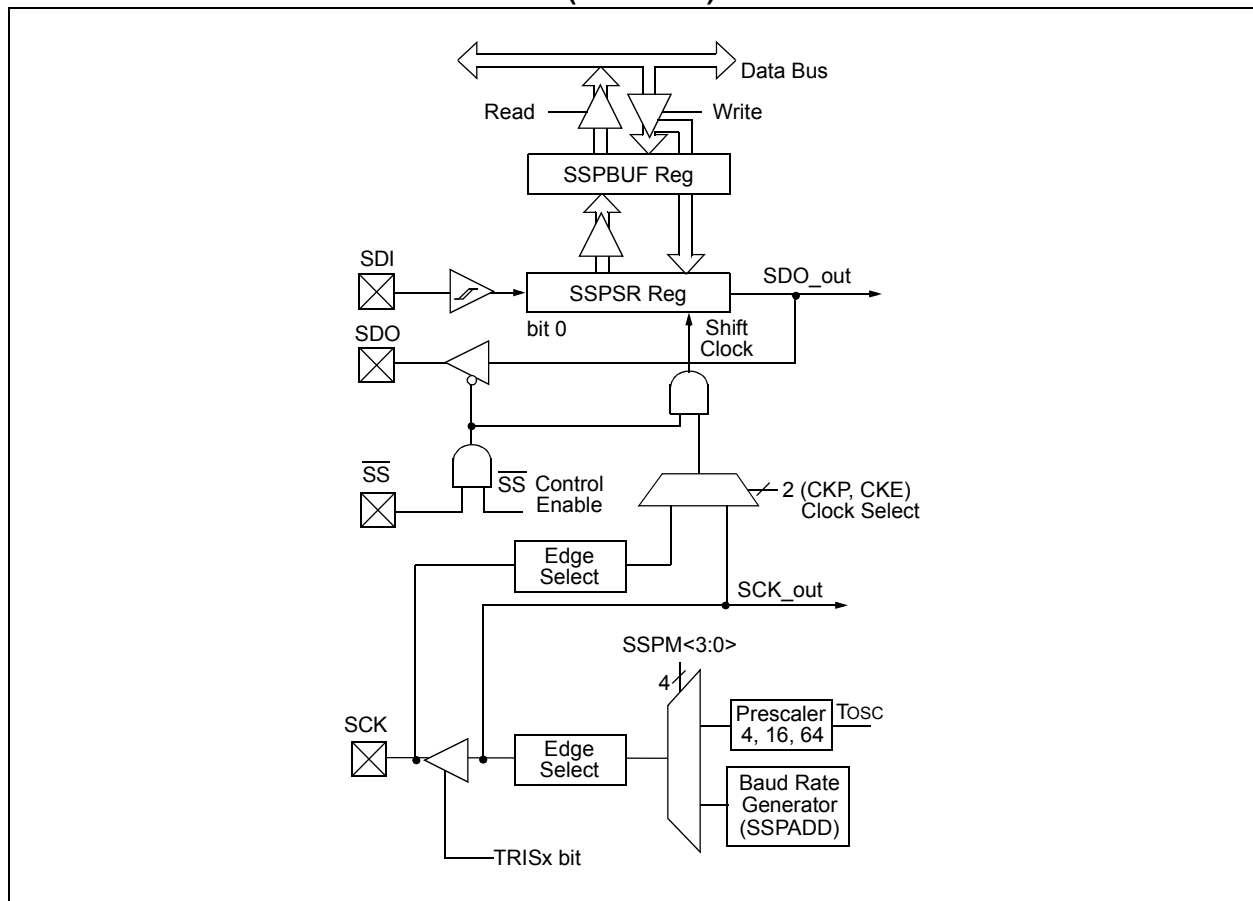

PIC16LF1554/1559

The I²C interface supports the following modes and features:

- Master mode
- Slave mode
- Byte NACKing (Slave mode)
- Limited multi-master support
- 7-bit and 10-bit addressing
- Start and Stop interrupts
- Interrupt masking
- Clock stretching
- Bus collision detection
- General call address matching
- Address masking
- Address Hold and Data Hold modes
- Selectable SDA hold times

Figure 20-2 is a block diagram of the I²C interface module in Master mode. Figure 20-3 is a diagram of the I²C interface module in Slave mode.

PIC16LF1554/1559 has one MSSP module.

FIGURE 20-2: MSSP BLOCK DIAGRAM (I²C™ MASTER MODE)

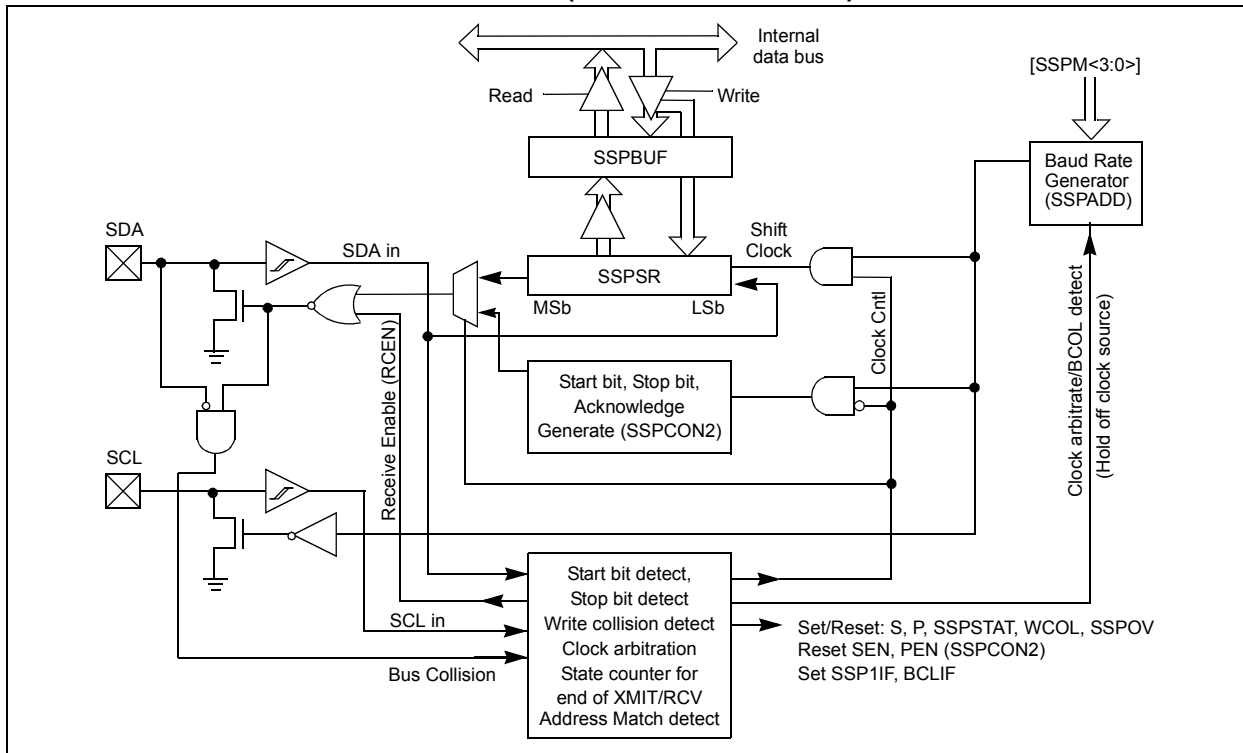
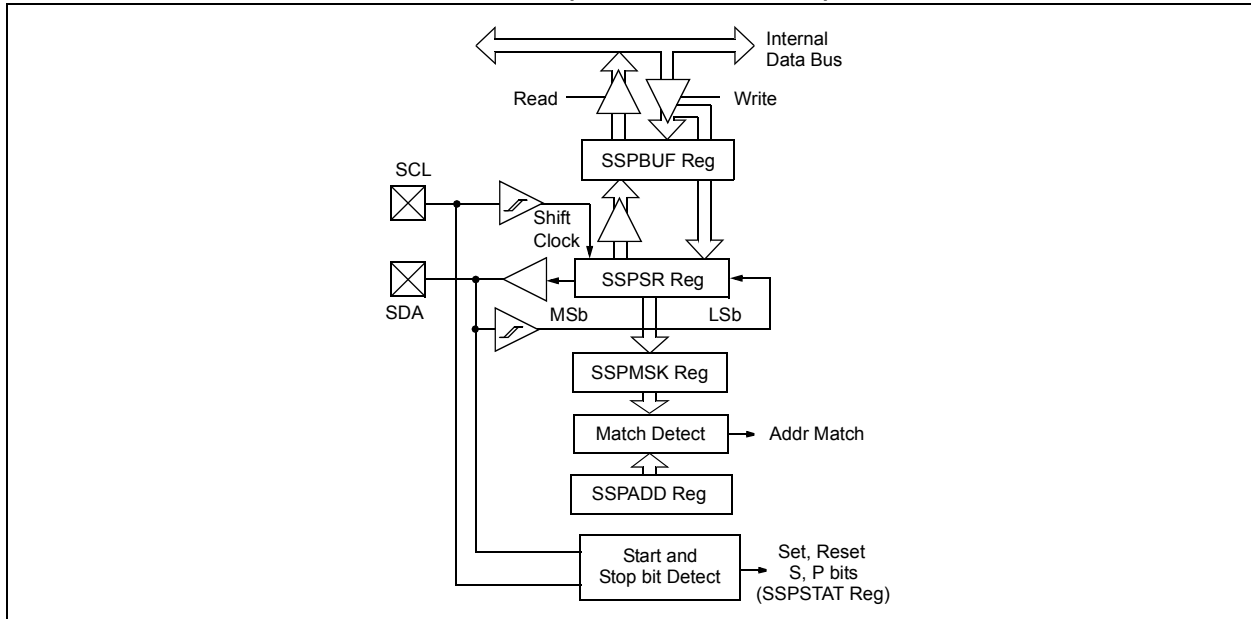

FIGURE 20-3: MSSP BLOCK DIAGRAM (I²C™ SLAVE MODE)



PIC16LF1554/1559

20.2 SPI Mode Overview

The Serial Peripheral Interface (SPI) bus is a synchronous serial data communication bus that operates in Full-Duplex mode. Devices communicate in a master/slave environment where the master device initiates the communication. A slave device is controlled through a Chip Select known as Slave Select.

The SPI bus specifies four signal connections:

- Serial Clock (SCK)
- Serial Data Out (SDO)
- Serial Data In (SDI)
- Slave Select (\overline{SS})

Figure 20-1 shows the block diagram of the MSSP module when operating in SPI mode.

The SPI bus operates with a single master device and one or more slave devices. When multiple slave devices are used, an independent Slave Select connection is required from the master device to each slave device.

Figure 20-4 shows a typical connection between a master device and multiple slave devices.

The master selects only one slave at a time. Most slave devices have tri-state outputs so their output signal appears disconnected from the bus when they are not selected.

Transmissions involve two shift registers, eight bits in size, one in the master and one in the slave. With either the master or the slave device, data is always shifted out one bit at a time, with the Most Significant bit (MSb) shifted out first. At the same time, a new Least Significant bit (LSb) is shifted into the same register.

Figure 20-5 shows a typical connection between two processors configured as master and slave devices.

Data is shifted out of both shift registers on the programmed clock edge and latched on the opposite edge of the clock.

The master device transmits information out on its SDO output pin which is connected to, and received by, the slave's SDI input pin. The slave device transmits information out on its SDO output pin, which is connected to, and received by, the master's SDI input pin.

To begin communication, the master device first sends out the clock signal. Both the master and the slave devices should be configured for the same clock polarity.

The master device starts a transmission by sending out the MSb from its shift register. The slave device reads this bit from that same line and saves it into the LSb position of its shift register.

During each SPI clock cycle, a full-duplex data transmission occurs. This means that while the master device is sending out the MSb from its shift register (on its SDO pin) and the slave device is reading this bit and saving it as the LSb of its shift register, that the slave device is also sending out the MSb from its shift register (on its SDO pin) and the master device is reading this bit and saving it as the LSb of its shift register.

After eight bits have been shifted out, the master and slave have exchanged register values.

If there is more data to exchange, the shift registers are loaded with new data and the process repeats itself.

Whether the data is meaningful or not (dummy data), depends on the application software. This leads to three scenarios for data transmission:

- Master sends useful data and slave sends dummy data.
- Master sends useful data and slave sends useful data.
- Master sends dummy data and slave sends useful data.

Transmissions may involve any number of clock cycles. When there is no more data to be transmitted, the master stops sending the clock signal and it deselects the slave.

Every slave device connected to the bus that has not been selected through its slave select line must disregard the clock and transmission signals and must not transmit out any data of its own.

FIGURE 20-4: SPI MASTER AND MULTIPLE SLAVE CONNECTION

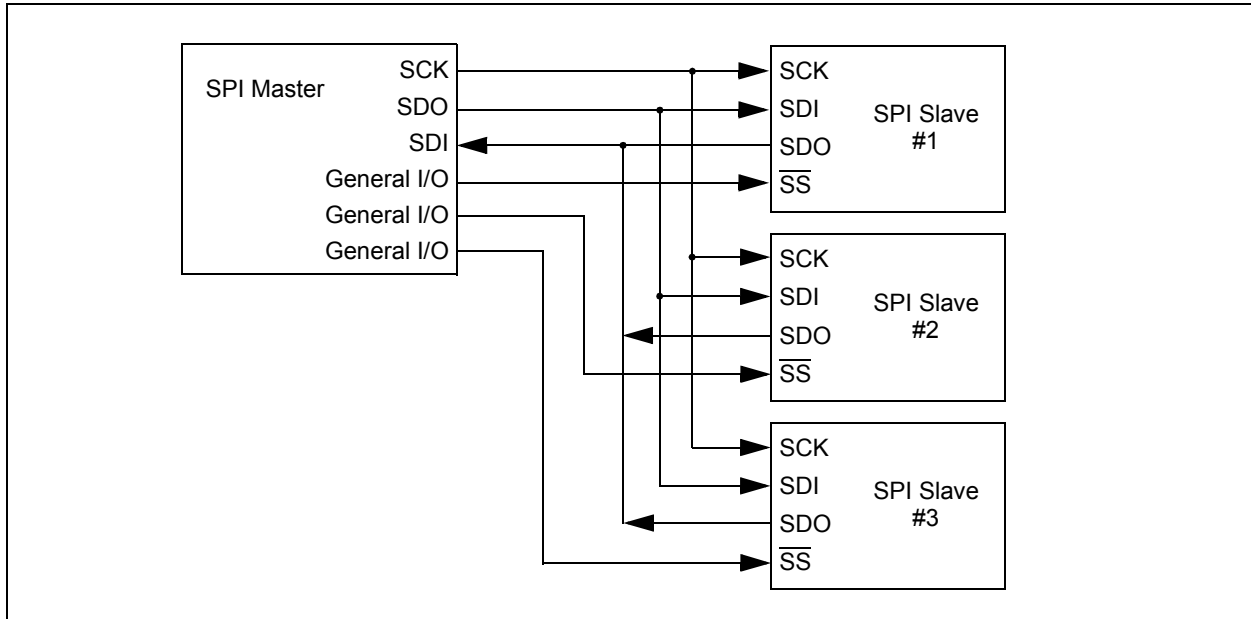

20.2.1 SPI MODE REGISTERS

The MSSP module has five registers for SPI mode operation. These are:

- MSSP STATUS register (SSPSTAT)
- MSSP Control Register 1 (SSPCON1)
- MSSP Control Register 3 (SSPCON3)
- MSSP Data Buffer register (SSPBUF)
- MSSP Address register (SSPADD)
- MSSP Shift register (SSPSR)
(Not directly accessible)

SSPCON1 and SSPSTAT are the control and STATUS registers in SPI mode operation. The SSPCON1 register is readable and writable. The lower six bits of the SSPSTAT are read-only. The upper two bits of the SSPSTAT are read/write.

In SPI master mode, SSPADD can be loaded with a value used in the Baud Rate Generator. More information on the Baud Rate Generator is available in [Section 20.7 “Baud Rate Generator”](#)

SSPSR is the shift register used for shifting data in and out. SSPBUF provides indirect access to the SSPSR register. SSPBUF is the buffer register to which data bytes are written, and from which data bytes are read.

In receive operations, SSPSR and SSPBUF together create a buffered receiver. When SSPSR receives a complete byte, it is transferred to SSPBUF and the SSP1IF interrupt is set.

During transmission, the SSPBUF is not buffered. A write to SSPBUF will write to both SSPBUF and SSPSR.

PIC16LF1554/1559

20.2.2 SPI MODE OPERATION

When initializing the SPI, several options need to be specified. This is done by programming the appropriate control bits (SSPCON1<5:0> and SSPSTAT<7:6>). These control bits allow the following to be specified:

- Master mode (SCK is the clock output)
- Slave mode (SCK is the clock input)
- Clock Polarity (Idle state of SCK)
- Data Input Sample Phase (middle or end of data output time)
- Clock Edge (output data on rising/falling edge of SCK)
- Clock Rate (Master mode only)
- Slave Select mode (Slave mode only)

To enable the serial port, SSP Enable bit, SSPEN of the SSPCON1 register, must be set. To reset or reconfigure SPI mode, clear the SSPEN bit, re-initialize the SSPCONx registers and then set the SSPEN bit. This configures the SDI, SDO, SCK and SS pins as serial port pins. For the pins to behave as the serial port function, some must have their data direction bits (in the TRISx register) appropriately programmed as follows:

- SDI must have corresponding TRISx bit set
- SDO must have corresponding TRISx bit cleared
- SCK (Master mode) must have corresponding TRISx bit cleared
- SCK (Slave mode) must have corresponding TRISx bit set
- SS must have corresponding TRISx bit set

Any serial port function that is not desired may be overridden by programming the corresponding data direction (TRISx) register to the opposite value.

The MSSP consists of a transmit/receive shift register (SSPSR) and a buffer register (SSPBUF). The SSPSR shifts the data in and out of the device, MSb first. The SSPBUF holds the data that was written to the SSPSR until the received data is ready. Once the eight bits of data have been received, that byte is moved to the SSPBUF register. Then, the Buffer Full Detect bit, BF of the SSPSTAT register, and the interrupt flag bit, SSP1IF, are set. This double-buffering of the received data (SSPBUF) allows the next byte to start reception before reading the data that was just received. Any write to the SSPBUF register during transmission/reception of data will be ignored and the write collision detect bit WCOL of the SSPCON1 register, will be set. User software must clear the WCOL bit to allow the following write(s) to the SSPBUF register to complete successfully.

When the application software is expecting to receive valid data, the SSPBUF should be read before the next byte of data to transfer is written to the SSPBUF. The Buffer Full bit, BF of the SSPSTAT register, indicates when SSPBUF has been loaded with the received data (transmission is complete). When the SSPBUF is read, the BF bit is cleared. This data may be irrelevant if the SPI is only a transmitter. Generally, the MSSP interrupt is used to determine when the transmission/reception has completed. If the interrupt method is not going to be used, then software polling can be done to ensure that a write collision does not occur.

The SSPSR is not directly readable or writable and can only be accessed by addressing the SSPBUF register. Additionally, the SSPSTAT register indicates the various Status conditions.

FIGURE 20-5: SPI MASTER/SLAVE CONNECTION

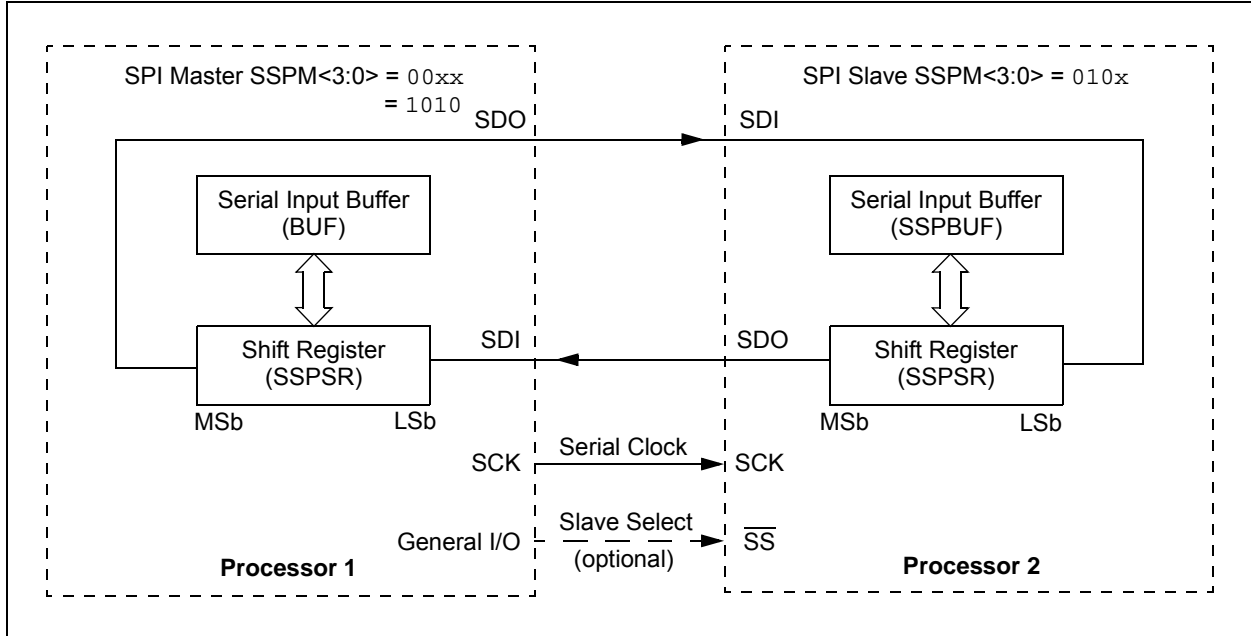

PIC16LF1554/1559

20.2.3 SPI MASTER MODE

The master can initiate the data transfer at any time because it controls the SCK line. The master determines when the slave (Processor 2, [Figure 20-5](#)) is to broadcast data by the software protocol.

In Master mode, the data is transmitted/received as soon as the SSPBUF register is written to. If the SPI is only going to receive, the SDO output could be disabled (programmed as an input). The SSPSR register will continue to shift in the signal present on the SDI pin at the programmed clock rate. As each byte is received, it will be loaded into the SSPBUF register as if a normal received byte (interrupts and Status bits appropriately set).

The clock polarity is selected by appropriately programming the CKP bit of the SSPCON1 register and the CKE bit of the SSPSTAT register. This then, would give waveforms for SPI communication as shown in [Figure 20-6](#), [Figure 20-8](#), [Figure 20-9](#) and [Figure 20-10](#), where the MSb is transmitted first. In Master mode, the SPI clock rate (bit rate) is user programmable to be one of the following:

- $F_{osc}/4$ (or T_{CY})
- $F_{osc}/16$ (or $4 * T_{CY}$)
- $F_{osc}/64$ (or $16 * T_{CY}$)
- $F_{osc}/(4 * (SSPADD + 1))$

[Figure 20-6](#) shows the waveforms for Master mode.

When the CKE bit is set, the SDO data is valid before there is a clock edge on SCK. The change of the input sample is shown based on the state of the SMP bit. The time when the SSPBUF is loaded with the received data is shown.

FIGURE 20-6: SPI MODE WAVEFORM (MASTER MODE)

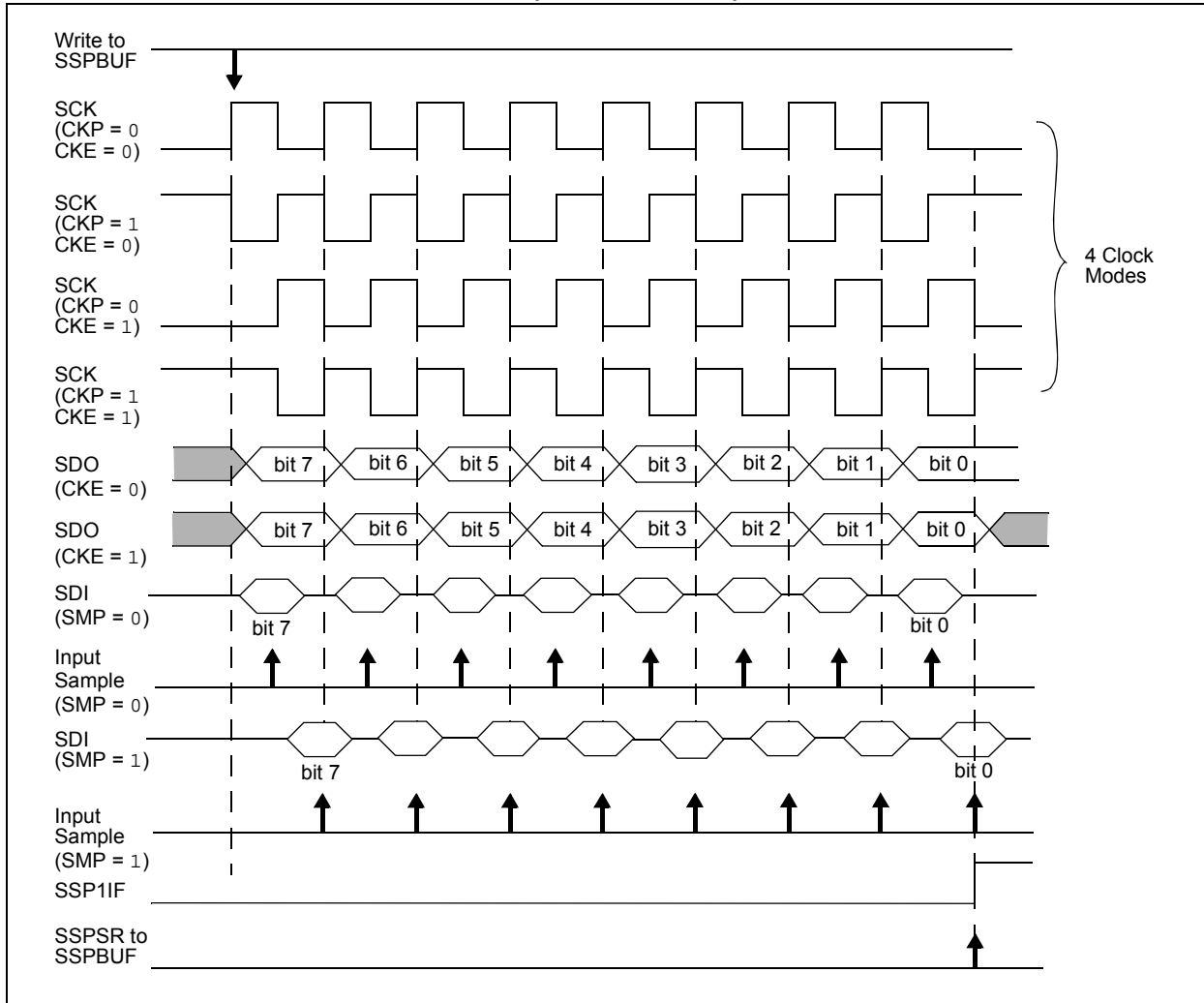

20.2.4 SPI SLAVE MODE

In Slave mode, the data is transmitted and received as external clock pulses appear on SCK. When the last bit is latched, the SSP1IF interrupt flag bit is set.

Before enabling the module in SPI Slave mode, the clock line must match the proper Idle state. The clock line can be observed by reading the SCK pin. The Idle state is determined by the CKP bit of the SSPCON1 register.

While in Slave mode, the external clock is supplied by the external clock source on the SCK pin. This external clock must meet the minimum high and low times as specified in the electrical specifications.

While in Sleep mode, the slave can transmit/receive data. The shift register is clocked from the SCK pin input and when a byte is received, the device will generate an interrupt. If enabled, the device will wake-up from Sleep.

20.2.4.1 Daisy-Chain Configuration

The SPI bus can sometimes be connected in a daisy-chain configuration. The first slave output is connected to the second slave input, the second slave output is connected to the third slave input, and so on. The final slave output is connected to the master input. Each slave sends out, during a second group of clock pulses, an exact copy of what was received during the first group of clock pulses. The whole chain acts as one large communication shift register. The daisy-chain feature only requires a single Slave Select line from the master device.

Figure 20-7 shows the block diagram of a typical daisy-chain connection when operating in SPI mode.

In a daisy-chain configuration, only the most recent byte on the bus is required by the slave. Setting the BOEN bit of the SSPCON3 register will enable writes to the SSPBUF register, even if the previous byte has not been read. This allows the software to ignore data that may not apply to it.

20.2.5 SLAVE SELECT SYNCHRONIZATION

The Slave Select can also be used to synchronize communication. The Slave Select line is held high until the master device is ready to communicate. When the Slave Select line is pulled low, the slave knows that a new transmission is starting.

If the slave fails to receive the communication properly, it will be reset at the end of the transmission, when the Slave Select line returns to a high state. The slave is then ready to receive a new transmission when the Slave Select line is pulled low again. If the Slave Select line is not used, there is a risk that the slave will eventually become out of sync with the master. If the slave misses a bit, it will always be one bit off in future transmissions. Use of the Slave Select line allows the slave and master to align themselves at the beginning of each transmission.

The \overline{SS} pin allows a Synchronous Slave mode. The SPI must be in Slave mode with \overline{SS} pin control enabled (SSPCON1<3:0> = 0100).

When the \overline{SS} pin is low, transmission and reception are enabled and the SDO pin is driven.

When the \overline{SS} pin goes high, the SDO pin is no longer driven, even if in the middle of a transmitted byte and becomes a floating output. External pull-up/pull-down resistors may be desirable depending on the application.

- | |
|---|
| <p>Note 1: When the SPI is in Slave mode with \overline{SS} pin control enabled (SSPCON1<3:0> = 0100), the SPI module will reset if the \overline{SS} pin is set to VDD.</p> <p>2: When the SPI is used in Slave mode with CKE set; the user must enable \overline{SS} pin control.</p> <p>3: While operated in SPI Slave mode the SMP bit of the SSPSTAT register must remain clear.</p> |
|---|

When the SPI module resets, the bit counter is forced to '0'. This can be done by either forcing the \overline{SS} pin to a high level or clearing the SSPEN bit.

PIC16LF1554/1559

FIGURE 20-7: SPI DAISY-CHAIN CONNECTION

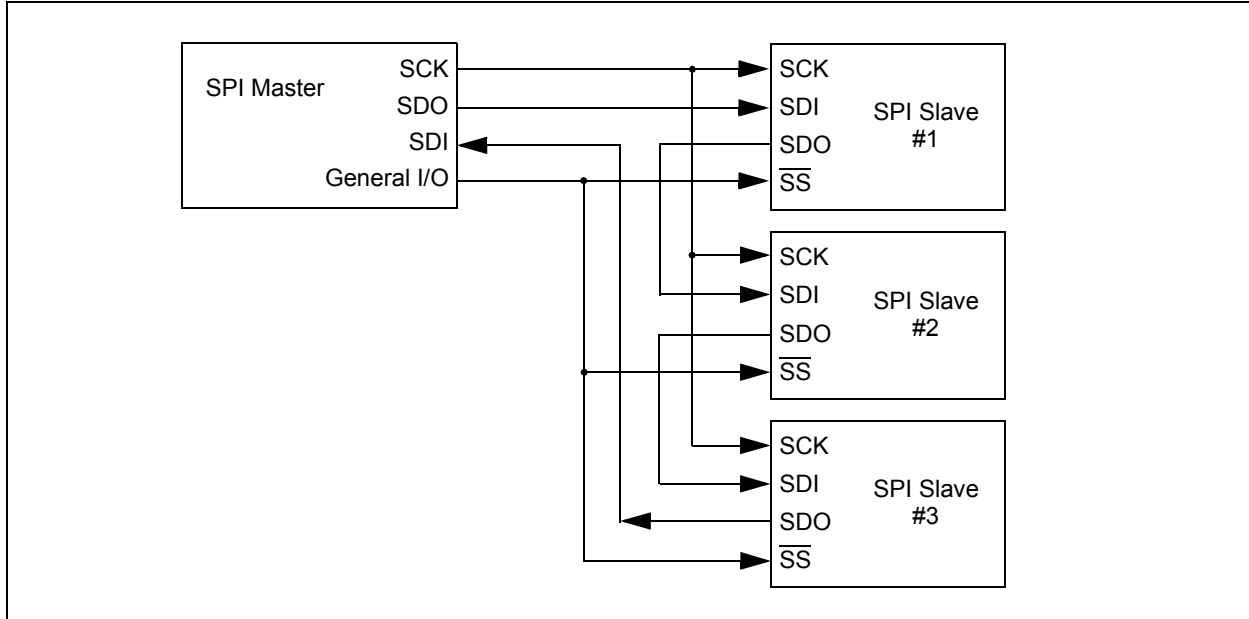

FIGURE 20-8: SLAVE SELECT SYNCHRONOUS WAVEFORM

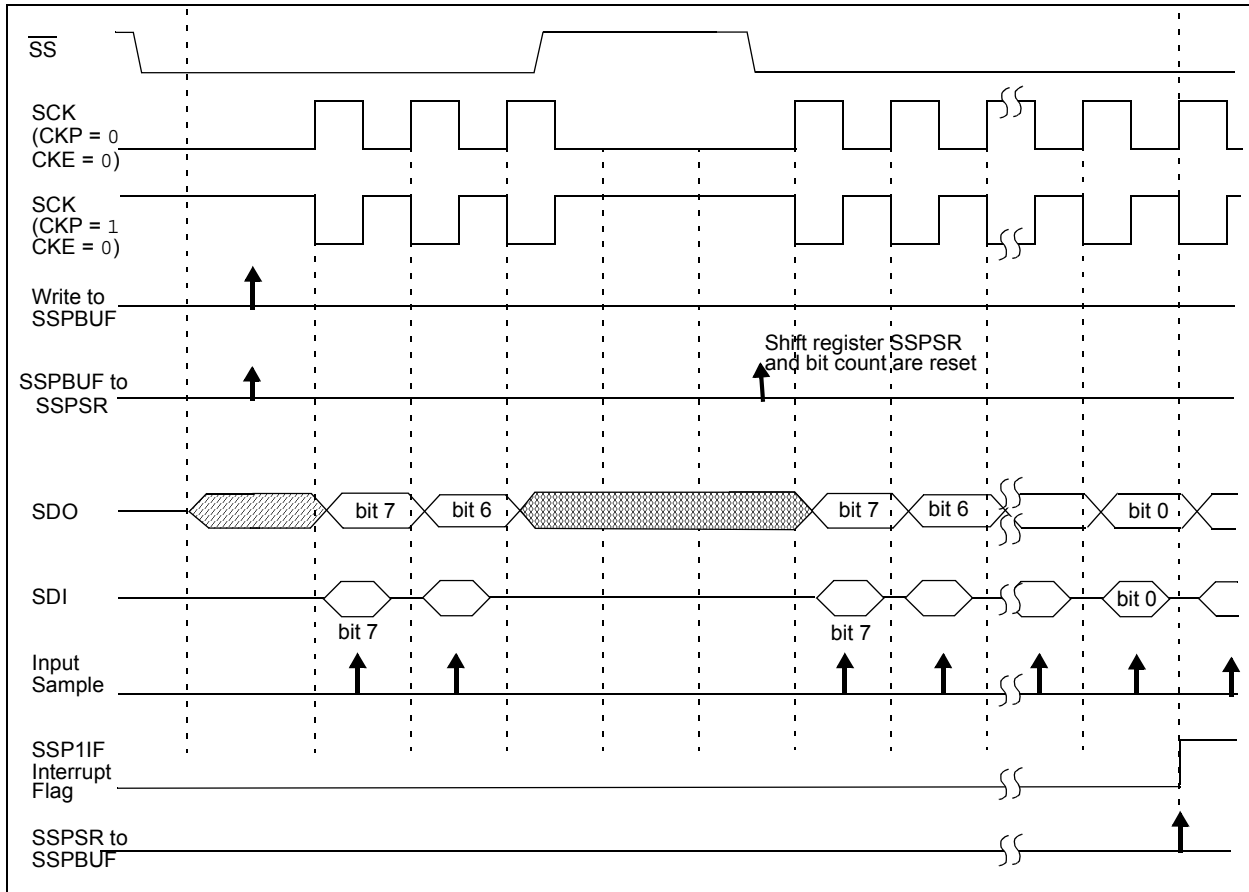

FIGURE 20-9: SPI MODE WAVEFORM (SLAVE MODE WITH CKE = 0)

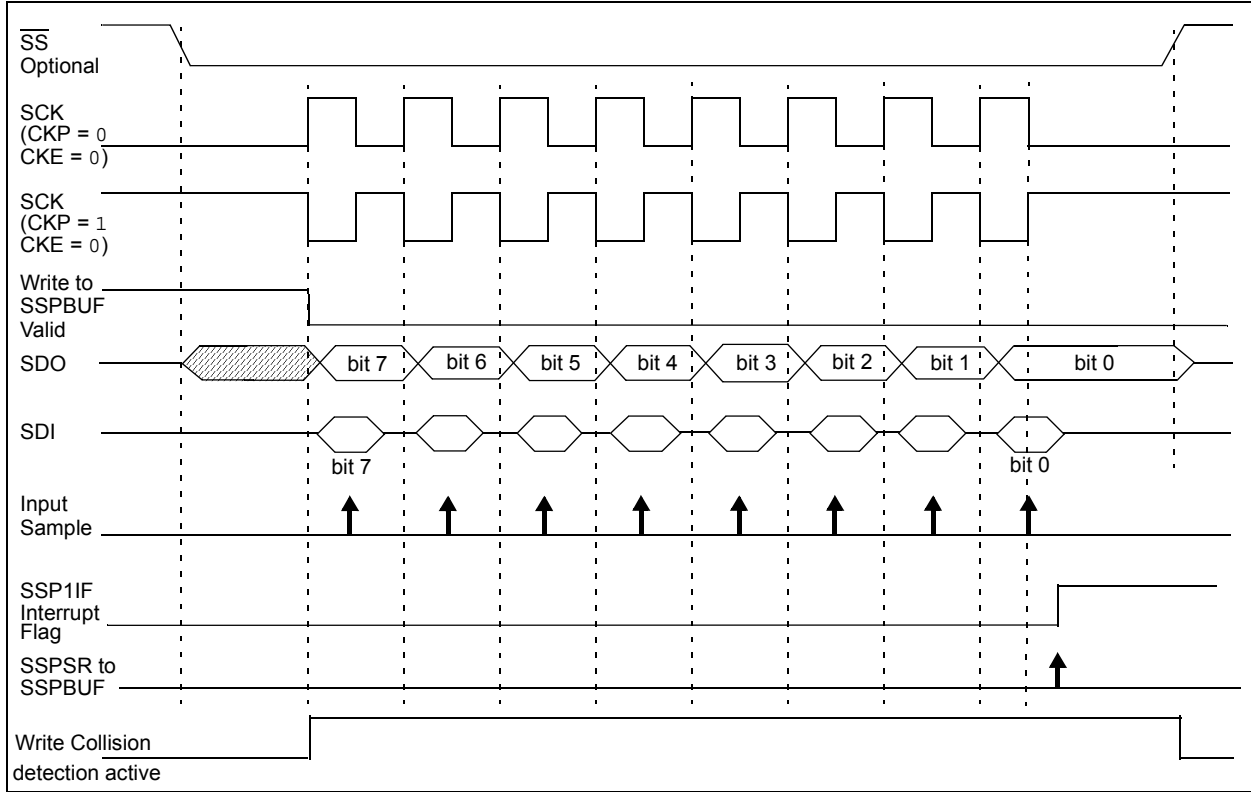
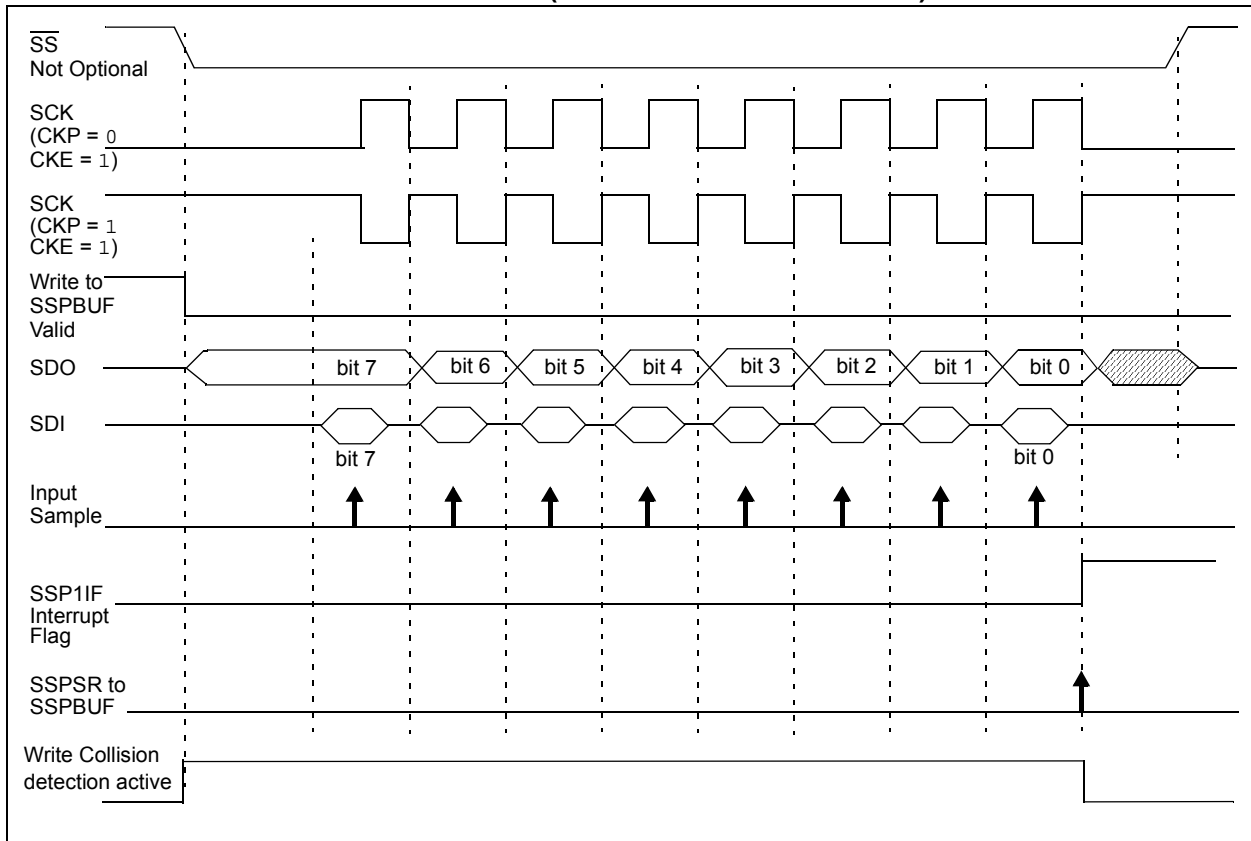

FIGURE 20-10: SPI MODE WAVEFORM (SLAVE MODE WITH CKE = 1)



PIC16LF1554/1559

20.2.6 SPI OPERATION IN SLEEP MODE

In SPI Master mode, module clocks may be operating at a different speed than when in Full-Power mode; in the case of the Sleep mode, all clocks are halted.

Special care must be taken by the user when the MSSP clock is much faster than the system clock.

In Slave mode, when MSSP interrupts are enabled, after the master completes sending data, an MSSP interrupt will wake the controller from Sleep.

If an exit from Sleep mode is not desired, MSSP interrupts should be disabled.

In SPI Master mode, when the Sleep mode is selected, all module clocks are halted and the transmission/reception will remain in that state until the device wakes. After the device returns to Run mode, the module will resume transmitting and receiving data.

In SPI Slave mode, the SPI Transmit/Receive Shift register operates asynchronously to the device. This allows the device to be placed in Sleep mode and data to be shifted into the SPI Transmit/Receive Shift register. When all eight bits have been received, the MSSP interrupt flag bit will be set and if enabled, will wake the device.

TABLE 20-1: SUMMARY OF REGISTERS ASSOCIATED WITH SPI OPERATION

Name	Bit 7	Bit 6	Bit 5	Bit 4	Bit 3	Bit 2	Bit 1	Bit 0	Register on Page
ANSELA	—	—	ANSA5	ANSA4	—	ANSA2	ANSA1	ANSA0	109
APFCON	RXDTSEL	SDOSEL	SSSEL	SDSEL	—	TXCKSEL	GRDBSEL	GRDASEL	106
INTCON	GIE	PEIE	TMR0IE	INTE	IOCIE	TMR0IF	INTF	IOCIF	77
PIE1	TMR1GIE	AD1IE	RCIE	TXIE	SSP1IE	—	TMR2IE	TMR1IE	78
PIR1	TMR1GIF	AD1IF	RCIF	TXIF	SSP1IF	—	TMR2IF	TMR1IF	80
SSPBUF	Synchronous Serial Port Receive Buffer/Transmit Register								185*
SSPCON1	WCOL	SSPOV	SSPEN	CKP	SSPM<3:0>				230
SSPCON3	ACKTIM	PCIE	SCIE	BOEN	SDAHT	SBCDE	AHEN	DHEN	232
SSPSTAT	SMP	CKE	D \bar{A}	P	S	R \bar{W}	UA	BF	229
TRISA	—	—	TRISA5	TRISA4	— ⁽¹⁾	TRISA2	TRISA1	TRISA0	108

Legend: — = Unimplemented location, read as '0'. Shaded cells are not used by the MSSP in SPI mode.

* Page provides register information.

Note 1: Unimplemented, read as '1'.

20.3 I²C MODE OVERVIEW

The Inter-Integrated Circuit Bus (I²C) is a multi-master serial data communication bus. Devices communicate in a master/slave environment where the master devices initiate the communication. A Slave device is controlled through addressing.

The I²C bus specifies two signal connections:

- Serial Clock (SCL)
- Serial Data (SDA)

Figure 20-2 and Figure 20-3 show the block diagrams of the MSSP module when operating in I²C mode.

Both the SCL and SDA connections are bidirectional open-drain lines, each requiring pull-up resistors for the supply voltage. Pulling the line to ground is considered a logical zero and letting the line float is considered a logical one.

Figure 20-11 shows a typical connection between two processors configured as master and slave devices.

The I²C bus can operate with one or more master devices and one or more slave devices.

There are four potential modes of operation for a given device:

- Master Transmit mode
(master is transmitting data to a slave)
- Master Receive mode
(master is receiving data from a slave)
- Slave Transmit mode
(slave is transmitting data to a master)
- Slave Receive mode
(slave is receiving data from the master)

To begin communication, a master device starts out in Master Transmit mode. The master device sends out a Start bit followed by the address byte of the slave it intends to communicate with. This is followed by a single Read/Write bit, which determines whether the master intends to transmit to or receive data from the slave device.

If the requested slave exists on the bus, it will respond with an Acknowledge bit, otherwise known as an ACK. The master then continues in either Transmit mode or Receive mode and the slave continues in the complement, either in Receive mode or Transmit mode, respectively.

A Start bit is indicated by a high-to-low transition of the SDA line while the SCL line is held high. Address and data bytes are sent out, Most Significant bit (MSb) first. The Read/Write bit is sent out as a logical one when the master intends to read data from the slave, and is sent out as a logical zero when it intends to write data to the slave.

FIGURE 20-11: I²C™ MASTER/SLAVE CONNECTION

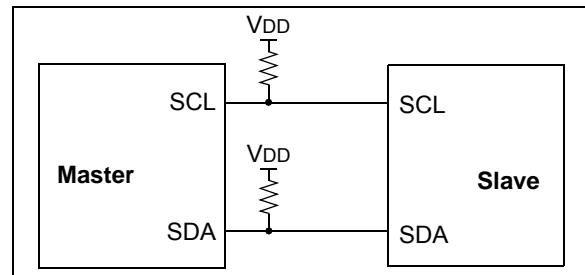

The Acknowledge bit ($\overline{\text{ACK}}$) is an active-low signal, which holds the SDA line low to indicate to the transmitter that the slave device has received the transmitted data and is ready to receive more.

The transition of a data bit is always performed while the SCL line is held low. Transitions that occur while the SCL line is held high are used to indicate Start and Stop bits.

If the master intends to write to the slave, then it repeatedly sends out a byte of data, with the slave responding after each byte with an ACK bit. In this example, the master device is in Master Transmit mode and the slave is in Slave Receive mode.

If the master intends to read from the slave, then it repeatedly receives a byte of data from the slave, and responds after each byte with an ACK bit. In this example, the master device is in Master Receive mode and the slave is Slave Transmit mode.

On the last byte of data communicated, the master device may end the transmission by sending a Stop bit. If the master device is in Receive mode, it first sends a not ACK bit in place of an ACK and then terminates the transfer with a Stop bit.

In some cases, the master may want to maintain control of the bus and re-initiate another transmission. If so, the master device may send another Start bit in place of the Stop bit or last ACK bit when it is in receive mode.

The I²C bus specifies three message protocols;

- Single message where a master writes data to a slave.
- Single message where a master reads data from a slave.
- Combined message where a master initiates a minimum of two writes, or two reads, or a combination of writes and reads, to one or more slaves.

When one device is transmitting a logical one, or letting the line float, and a second device is transmitting a logical zero, or holding the line low, the first device can detect that the line is not a logical one. This detection, when used on the SCL line, is called clock stretching. Clock stretching gives slave devices a mechanism to control the flow of data. When this detection is used on

PIC16LF1554/1559

the SDA line, it is called arbitration. Arbitration ensures that there is only one master device communicating at any single time.

20.3.1 CLOCK STRETCHING

When a slave device has not completed processing data, it can delay the transfer of more data through the process of clock stretching. An addressed slave device may hold the SCL clock line low after receiving or sending a bit, indicating that it is not yet ready to continue. The master that is communicating with the slave will attempt to raise the SCL line in order to transfer the next bit, but will detect that the clock line has not yet been released. Because the SCL connection is open-drain, the slave has the ability to hold that line low until it is ready to continue communicating.

Clock stretching allows receivers that cannot keep up with a transmitter to control the flow of incoming data.

20.3.2 ARBITRATION

Each master device must monitor the bus for Start and Stop bits. If the device detects that the bus is busy, it cannot begin a new message until the bus returns to an Idle state.

However, there are three conditions under which a collision can occur:

- a) Two master devices may try to initiate a transmission on or about the same time
- b) A device acting as multiple devices on the bus (one of which is acting as a master) may collide with another master which is trying to access a slave address on the first device
- c) Two slaves may respond to a general call read at the same time

20.3.2.1 Multi-Master Collision

In the first condition each master transmitter checks the level of the SDA data line and compares it to the level that it expects to find. The first transmitter to observe that the two levels do not match loses arbitration and must stop transmitting on the SDA line. For example, if one transmitter holds the SDA line to a logical one (lets it float) and a second transmitter holds it to a logical zero (pulls it low), the result is that the SDA line will be low.

The first transmitter then observes that the level of the line is different than expected and concludes that another transmitter is communicating. The first transmitter to notice this difference is the one that loses arbitration and must stop driving the SDA line. If this transmitter is also a master device, it must also stop driving the SCL line. Then it can monitor the lines for a Stop condition before trying to reissue its transmission. In the meantime, the other device that has not noticed any difference between the expected

and actual levels on the SDA line continues with its original transmission. It can do so without any complications because, so far, the transmission appears exactly as expected with no other transmitter disturbing the message.

20.3.2.2 Multi-Master with Slave Recovery

In the second condition there are essentially three entities on the bus: a master and a slave that reside within the same device, and a second master attempting to access the slave. If the master coupled to the slave loses the arbitration, then the slave must be able to recover and correctly respond to the second master. To accomplish this, the master which shares a device with the slave must use the I²C Firmware Controller Master mode of operation. This mode utilizes software to perform the master function, while the slave monitors the bus as a separate entity allowing it to respond to the second master.

To detect a collision, each device transmitting on the bus must check the level of the SDA data line and compare it to the level that it expects to find. The first transmitter to observe that the two levels do not match loses arbitration, and it must drop off the bus as well as stop transmitting on the SDA line if it is acting as a master. For example, if one transmitter holds the SDA line to a logical one (lets it float) and a second transmitter holds it to a logical zero (pulls it low), the result is that the SDA line will be low.

If two master devices send a message to two different slave devices at the address stage, the master sending the lower slave address always wins arbitration. When two master devices send messages to the same slave address, and addresses can sometimes refer to multiple slaves, the arbitration process must continue into the data stage.

20.3.2.3 Multi-Slave Collision

When a system attempts a slave read from the general call address, there is the possibility that more than one slave devices may attempt to return data to the master. When this happens, a read collision occurs and the slaves which fail the arbitration must fall off the bus and allow the winning device to continue its data transmission. Once the winning device has completed its data transfer, the master can then initiate an additional read from the general call address to retrieve the second slave's data. In large systems this may require multiple reads by the master. Several protocols use this feature and the MSSP hardware incorporates a detection mechanism in the slave read to detect the condition and respond appropriately.

In most designs, arbitration usually occurs very rarely, but it is a necessary process for proper multi-master support or even multi-slave systems that use general call address reads.

20.4 I²C MODE OPERATION

All MSSP I²C communication is byte oriented and shifted out MSb first. Six SFR registers and two interrupt flags interface the module with the PIC[®] microcontroller and user software. Two pins, SDA and SCL, are exercised by the module to communicate with other external I²C devices.

20.4.1 BYTE FORMAT

All communication in I²C is done in 9-bit segments. A byte is sent from a master to a slave or vice-versa, followed by an Acknowledge bit sent back. After the 8th falling edge of the SCL line, the device outputting data on the SDA changes that pin to an input and reads in an acknowledge value on the next clock pulse.

The clock signal, SCL, is provided by the master. Data is valid to change while the SCL signal is low, and sampled on the rising edge of the clock. Changes on the SDA line while the SCL line is high define special conditions on the bus, explained below.

20.4.2 DEFINITION OF I²C TERMINOLOGY

There is language and terminology in the description of I²C communication that have definitions specific to I²C. That word usage is defined below and may be used in the rest of this document without explanation. This table was adapted from the Philips I²C[™] specification.

20.4.3 SDA AND SCL PINS

Selection of any I²C mode with the SSPEN bit set, forces the SCL and SDA pins to be open-drain. These pins should be set by the user to inputs by setting the appropriate TRISx bits.

Note: Data is tied to output zero when an I²C mode is enabled.

20.4.4 SDA HOLD TIME

The hold time of the SDA pin is selected by the SDAHT bit of the SSPCON3 register. Hold time is the time SDA is held valid after the falling edge of SCL. Setting the SDAHT bit selects a longer 300 ns minimum hold time and may help on buses with large capacitance.

TABLE 20-2: I²C[™] BUS TERMS

TERM	Description
Transmitter	The device which shifts data out onto the bus.
Receiver	The device which shifts data in from the bus.
Master	The device that initiates a transfer, generates clock signals and terminates a transfer.
Slave	The device addressed by the master.
Multi-master	A bus with more than one device that can initiate data transfers.
Arbitration	Procedure to ensure that only one master at a time controls the bus. Winning arbitration ensures that the message is not corrupted.
Synchronization	Procedure to synchronize the clocks of two or more devices on the bus.
Idle	No master is controlling the bus, and both SDA and SCL lines are high.
Active	Any time one or more master devices are controlling the bus.
Addressed Slave	Slave device that has received a matching address and is actively being clocked by a master.
Matching Address	Address byte that is clocked into a slave that matches the value stored in SSPADD.
Write Request	Slave receives a matching address with R/W bit clear, and is ready to clock in data.
Read Request	Master sends an address byte with the R/W bit set, indicating that it wishes to clock data out of the slave. This data is the next and all following bytes until a Restart or Stop.
Clock Stretching	When a device on the bus hold SCL low to stall communication.
Bus Collision	Any time the SDA line is sampled low by the module while it is outputting and expected high state.

PIC16LF1554/1559

20.4.5 START CONDITION

The I²C specification defines a Start condition as a transition of SDA from a high to a low state while SCL line is high. A Start condition is always generated by the master and signifies the transition of the bus from an Idle to an Active state. Figure 20-12 shows wave forms for Start and Stop conditions.

A bus collision can occur on a Start condition if the module samples the SDA line low before asserting it low. This does not conform to the I²C Specification that states no bus collision can occur on a Start.

20.4.6 STOP CONDITION

A Stop condition is a transition of the SDA line from low-to-high state while the SCL line is high.

Note: At least one SCL low time must appear before a Stop is valid, therefore, if the SDA line goes low then high again while the SCL line stays high, only the Start condition is detected.

20.4.7 RESTART CONDITION

A Restart is valid any time that a Stop would be valid. A master can issue a Restart if it wishes to hold the bus after terminating the current transfer. A Restart has the same effect on the slave that a Start would, resetting all slave logic and preparing it to clock in an address. The master may want to address the same or another slave. Figure 20-13 shows the wave form for a Restart condition.

In 10-bit Addressing Slave mode a Restart is required for the master to clock data out of the addressed slave. Once a slave has been fully addressed, matching both high and low address bytes, the master can issue a Restart and the high address byte with the R/W bit set. The slave logic will then hold the clock and prepare to clock out data.

After a full match with R/W clear in 10-bit mode, a prior match flag is set and maintained. Until a Stop condition, a high address with R/W clear, or high address match fails.

20.4.8 START/STOP CONDITION INTERRUPT MASKING

The SCIE and PCIE bits of the SSPCON3 register can enable the generation of an interrupt in Slave modes that do not typically support this function. Slave modes where interrupt on Start and Stop detect are already enabled, these bits will have no effect.

FIGURE 20-12: I²C™ START AND STOP CONDITIONS

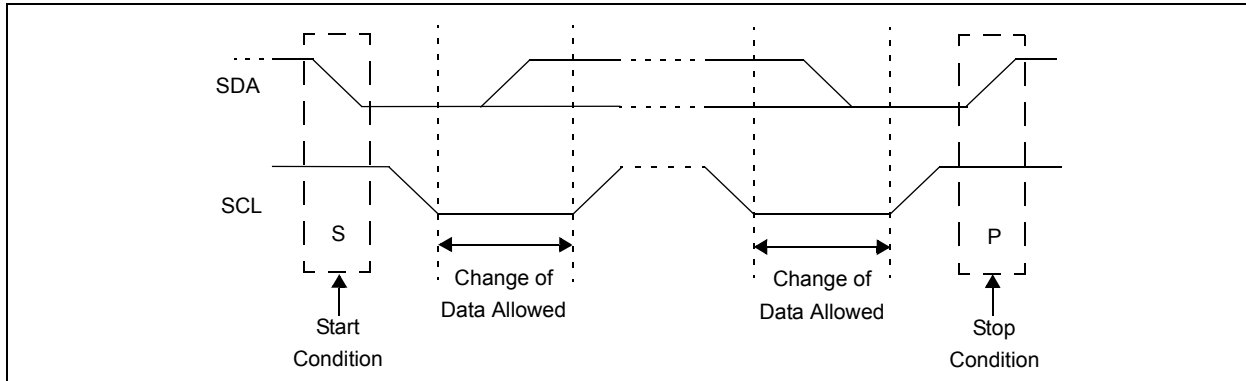
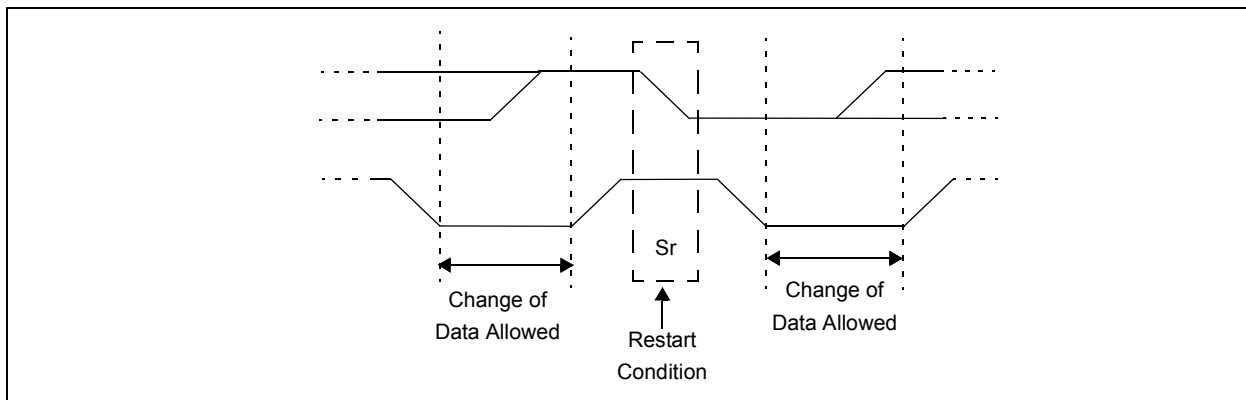

FIGURE 20-13: I²C™ RESTART CONDITION



20.4.9 ACKNOWLEDGE SEQUENCE

The 9th SCL pulse for any transferred byte in I²C is dedicated as an Acknowledge. It allows receiving devices to respond back to the transmitter by pulling the SDA line low. The transmitter must release control of the line during this time to shift in the response. The Acknowledge ($\overline{\text{ACK}}$) is an active-low signal, pulling the SDA line low indicated to the transmitter that the device has received the transmitted data and is ready to receive more.

The result of an $\overline{\text{ACK}}$ is placed in the ACKSTAT bit of the SSPCON2 register.

Slave software, when the AHEN and DHEN bits are set, allow the user to set the $\overline{\text{ACK}}$ value sent back to the transmitter. The ACKDT bit of the SSPCON2 register is set/cleared to determine the response.

Slave hardware will generate an $\overline{\text{ACK}}$ response if the AHEN and DHEN bits of the SSPCON3 register are clear.

There are certain conditions where an $\overline{\text{ACK}}$ will not be sent by the slave. If the BF bit of the SSPSTAT register or the SSPOV bit of the SSPCON1 register are set when a byte is received.

When the module is addressed, after the 8th falling edge of SCL on the bus, the ACKTIM bit of the SSPCON3 register is set. The ACKTIM bit indicates the acknowledge time of the active bus. The ACKTIM Status bit is only active when the AHEN bit or DHEN bit is enabled.

20.5 I²C SLAVE MODE OPERATION

The MSSP Slave mode operates in one of four modes selected in the SSPM bits of the SSPCON1 register. The modes can be divided into 7-bit and 10-bit Addressing mode. 10-bit Addressing modes operate the same as 7-bit with some additional overhead for handling the larger addresses.

Modes with Start and Stop bit interrupts operate the same as the other modes with SSP1IF additionally getting set upon detection of a Start, Restart, or Stop condition.

20.5.1 SLAVE MODE ADDRESSES

The SSPADD register ([Register 20-6](#)) contains the Slave mode address. The first byte received after a Start or Restart condition is compared against the value stored in this register. If the byte matches, the value is loaded into the SSPBUF register and an interrupt is generated. If the value does not match, the module goes idle and no indication is given to the software that anything happened.

The SSP Mask register ([Register 20-5](#)) affects the address matching process. See [Section 20.5.9 “SSP Mask Register”](#) for more information.

20.5.1.1 I²C Slave 7-Bit Addressing Mode

In 7-bit Addressing mode, the LSB of the received data byte is ignored when determining if there is an address match.

20.5.1.2 I²C Slave 10-Bit Addressing Mode

In 10-bit Addressing mode, the first received byte is compared to the binary value of '1 1 1 0 A9 A8 0'. A9 and A8 are the two MSb of the 10-bit address and stored in bits 2 and 1 of the SSPADD register.

After the acknowledge of the high byte the UA bit is set and SCL is held low until the user updates SSPADD with the low address. The low address byte is clocked in and all eight bits are compared to the low address value in SSPADD. Even if there is not an address match; SSP1IF and UA are set, and SCL is held low until SSPADD is updated to receive a high byte again. When SSPADD is updated the UA bit is cleared. This ensures the module is ready to receive the high address byte on the next communication.

A high and low address match as a write request is required at the start of all 10-bit addressing communication. A transmission can be initiated by issuing a Restart once the slave is addressed, and clocking in the high address with the R/W bit set. The slave hardware will then acknowledge the read request and prepare to clock out data. This is only valid for a slave after it has received a complete high and low address byte match.

PIC16LF1554/1559

20.5.2 SLAVE RECEPTION

When the $\overline{R/W}$ bit of a matching received address byte is clear, the R/W bit of the SSPSTAT register is cleared. The received address is loaded into the SSPBUF register and acknowledged.

When the overflow condition exists for a received address, then not Acknowledge is given. An overflow condition is defined as either bit BF of the SSPSTAT register is set, or bit SSPOV of the SSPCON1 register is set. The BOEN bit of the SSPCON3 register modifies this operation. For more information see [Register 20-4](#).

An MSSP interrupt is generated for each transferred data byte. Flag bit, SSP1IF, must be cleared by software.

When the SEN bit of the SSPCON2 register is set, SCL will be held low (clock stretch) following each received byte. The clock must be released by setting the CKP bit of the SSPCON1 register, except sometimes in 10-bit mode. See [Section 20.2.3 “SPI Master Mode”](#) for more detail.

20.5.2.1 7-Bit Addressing Reception

This section describes a standard sequence of events for the MSSP module configured as an I²C Slave in 7-bit Addressing mode. [Figure 20-14](#) and [Figure 20-15](#) are used as visual references for this description.

This is a step by step process of what typically must be done to accomplish I²C communication.

1. Start bit detected.
2. S bit of SSPSTAT is set; SSP1IF is set if interrupt on Start detect is enabled.
3. Matching address with $\overline{R/W}$ bit clear is received.
4. The slave pulls SDA low sending an \overline{ACK} to the master, and sets SSP1IF bit.
5. Software clears the SSP1IF bit.
6. Software reads received address from SSPBUF clearing the BF flag.
7. If SEN = 1; Slave software sets CKP bit to release the SCL line.
8. The master clocks out a data byte.
9. Slave drives SDA low sending an \overline{ACK} to the master, and sets SSP1IF bit.
10. Software clears SSP1IF.
11. Software reads the received byte from SSPBUF clearing BF.
12. Steps 8-12 are repeated for all received bytes from the Master.
13. Master sends Stop condition, setting P bit of SSPSTAT, and the bus goes idle.

20.5.2.2 7-Bit Reception with AHEN and DHEN

Slave device reception with AHEN and DHEN set operate the same as without these options with extra interrupts and clock stretching added after the 8th falling edge of SCL. These additional interrupts allow the slave software to decide whether it wants to \overline{ACK} the receive address or data byte, rather than the hardware. This functionality adds support for PMBus™ that was not present on previous versions of this module.

This list describes the steps that need to be taken by slave software to use these options for I²C communication. [Figure 20-16](#) displays a module using both address and data holding. [Figure 20-17](#) includes the operation with the SEN bit of the SSPCON2 register set.

1. S bit of SSPSTAT is set; SSP1IF is set if interrupt on Start detect is enabled.
2. Matching address with $\overline{R/W}$ bit clear is clocked in. SSP1IF is set and CKP cleared after the 8th falling edge of SCL.
3. Slave clears the SSP1IF.
4. Slave can look at the ACKTIM bit of the SSPCON3 register to determine if the SSP1IF was after or before the \overline{ACK} .
5. Slave reads the address value from SSPBUF, clearing the BF flag.
6. Slave sets \overline{ACK} value clocked out to the master by setting ACKDT.
7. Slave releases the clock by setting CKP.
8. SSP1IF is set after an \overline{ACK} , not after a NACK.
9. If SEN = 1 the slave hardware will stretch the clock after the \overline{ACK} .
10. Slave clears SSP1IF.

Note: SSP1IF is still set after the 9th falling edge of SCL even if there is no clock stretching and BF has been cleared. Only if NACK is sent to Master is SSP1IF not set

11. SSP1IF set and CKP cleared after 8th falling edge of SCL for a received data byte.
12. Slave looks at ACKTIM bit of SSPCON3 to determine the source of the interrupt.
13. Slave reads the received data from SSPBUF clearing BF.
14. Steps 7-14 are the same for each received data byte.
15. Communication is ended by either the slave sending an $\overline{ACK} = 1$, or the master sending a Stop condition. If a Stop is sent and Interrupt-on-Stop Detect is disabled, the slave will only know by polling the P bit of the SSPSTAT register.

FIGURE 20-14: I²C™ SLAVE, 7-BIT ADDRESS, RECEPTION (SEN = 0, AHEN = 0, DHEN = 0)

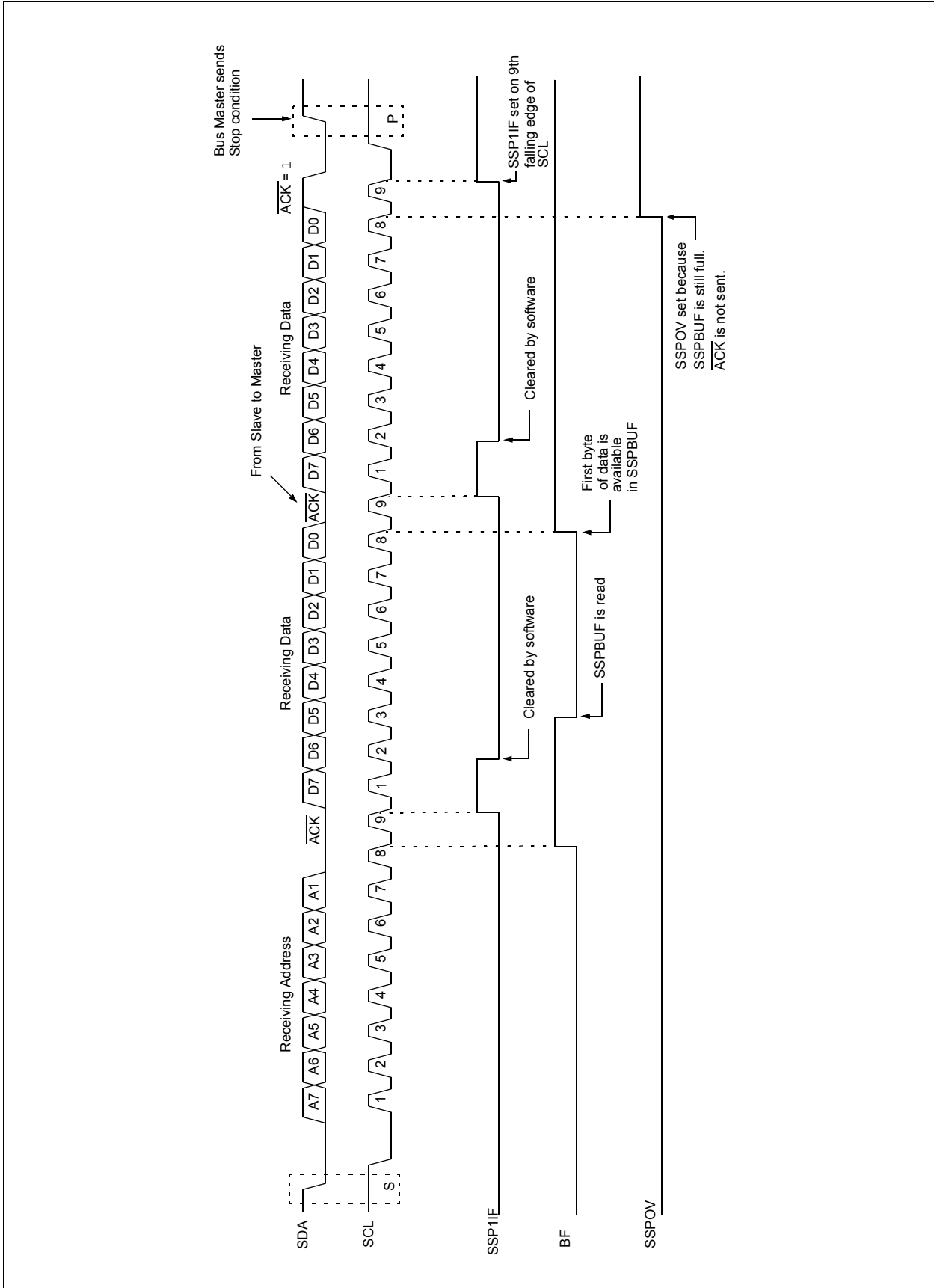

PIC16LF1554/1559

FIGURE 20-15: I²C™ SLAVE, 7-BIT ADDRESS, RECEPTION (SEN = 1, AHEN = 0, DHEN = 0)

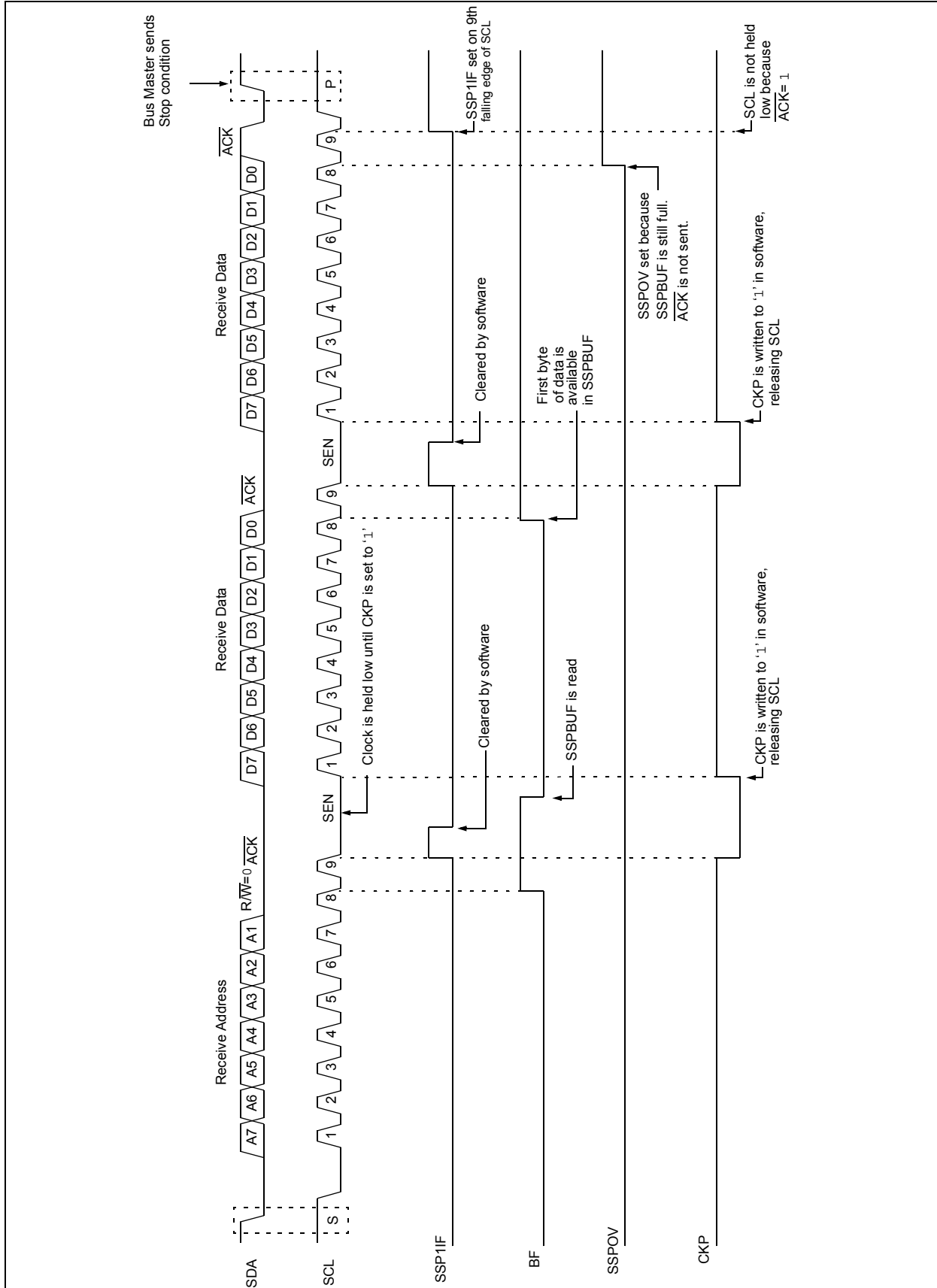
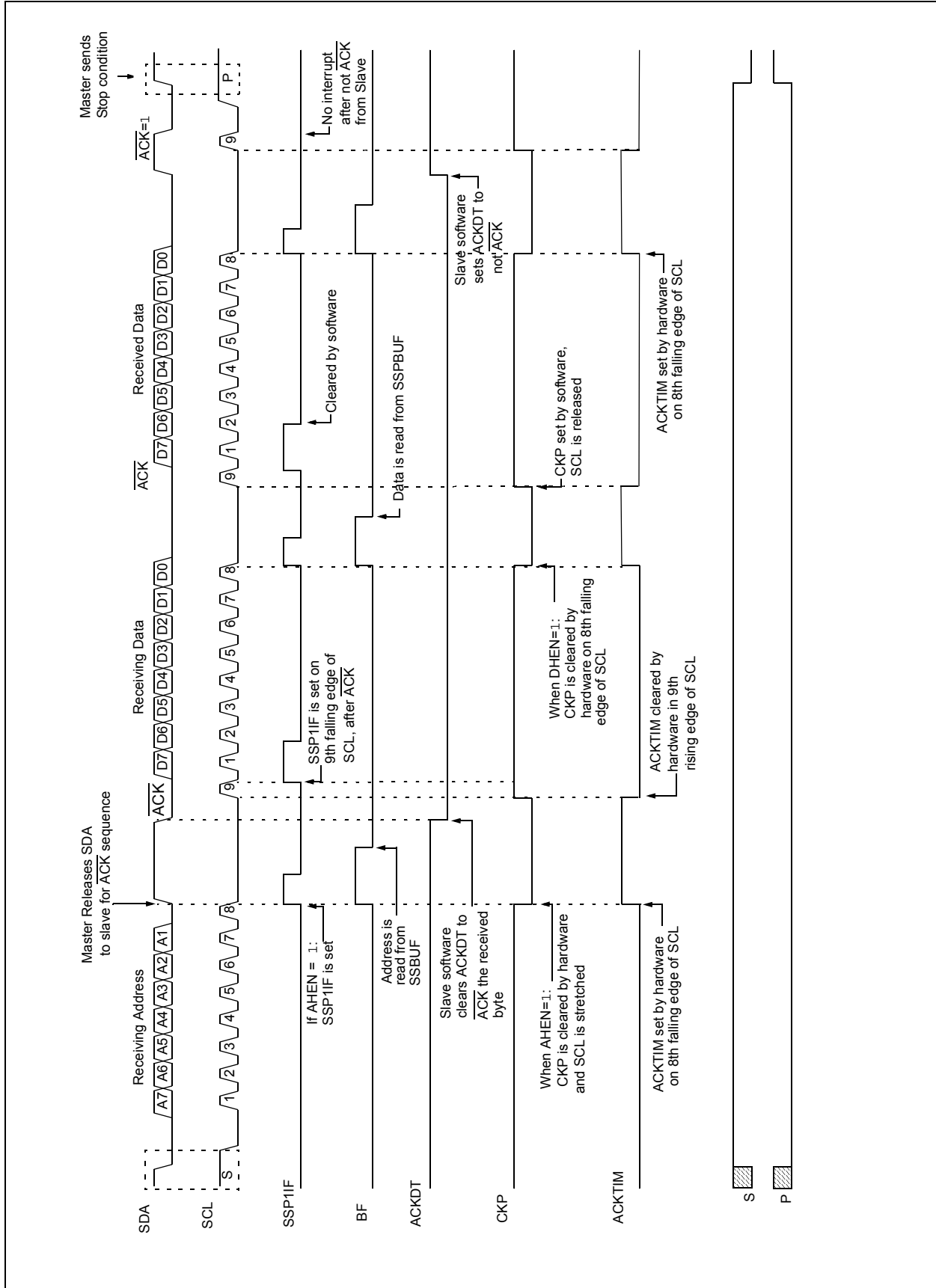
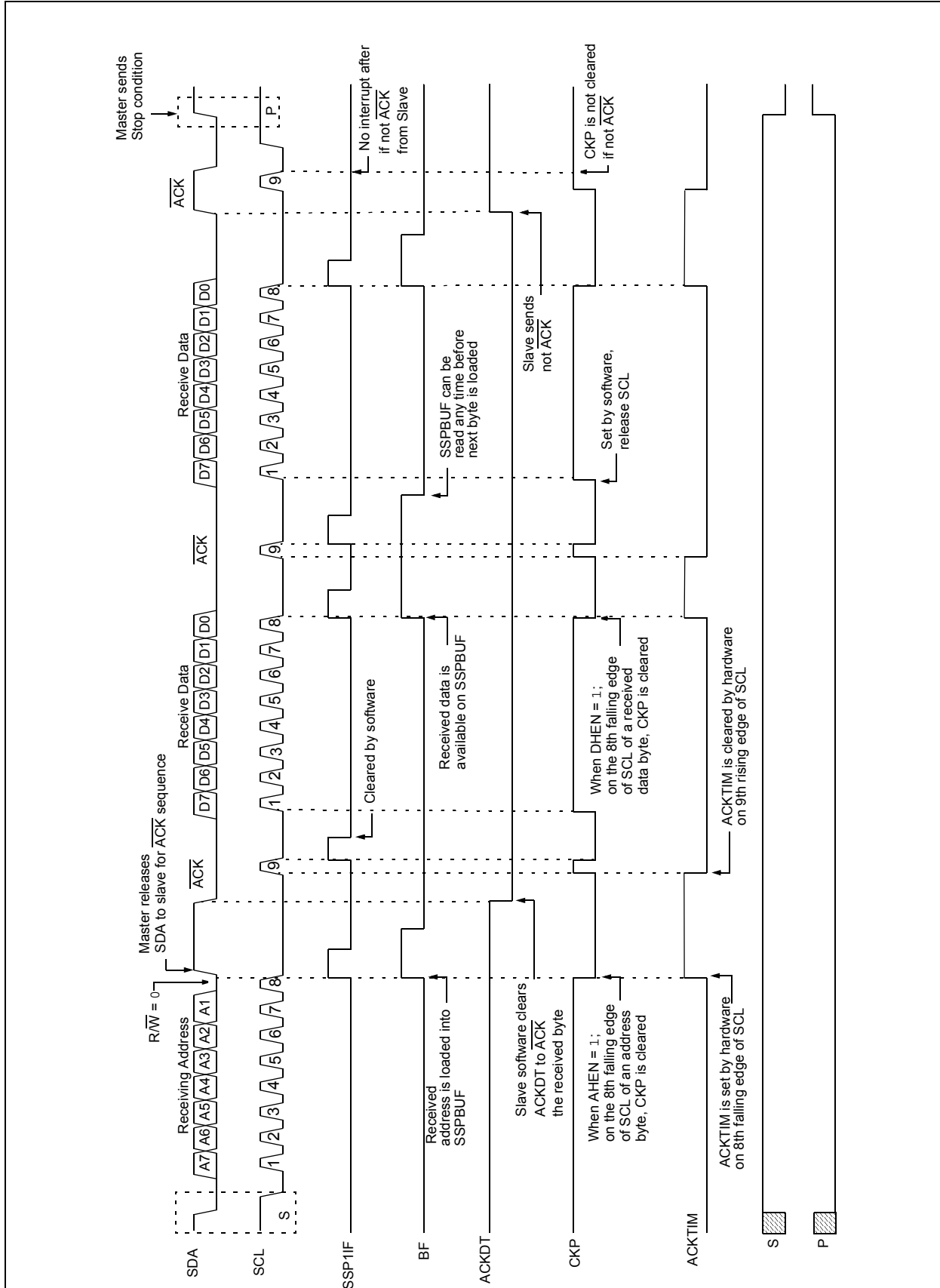

FIGURE 20-16: I²C™ SLAVE, 7-BIT ADDRESS, RECEPTION (SEN = 0, AHEN = 1, DHEN = 1)



PIC16LF1554/1559

FIGURE 20-17: I²C™ SLAVE, 7-BIT ADDRESS, RECEPTION (SEN = 1, AHEN = 1, DHEN = 1)



20.5.3 SLAVE TRANSMISSION

When the $\overline{R/W}$ bit of the incoming address byte is set and an address match occurs, the $\overline{R/W}$ bit of the SSPSTAT register is set. The received address is loaded into the SSPBUF register, and an \overline{ACK} pulse is sent by the slave on the ninth bit.

Following the \overline{ACK} , slave hardware clears the CKP bit and the SCL pin is held low (see [Section 20.5.6 “Clock Stretching”](#) for more detail). By stretching the clock, the master will be unable to assert another clock pulse until the slave is done preparing the transmit data.

The transmit data must be loaded into the SSPBUF register which also loads the SSPSR register. Then the SCL pin should be released by setting the CKP bit of the SSPCON1 register. The eight data bits are shifted out on the falling edge of the SCL input. This ensures that the SDA signal is valid during the SCL high time.

The \overline{ACK} pulse from the master-receiver is latched on the rising edge of the ninth SCL input pulse. This \overline{ACK} value is copied to the ACKSTAT bit of the SSPCON2 register. If ACKSTAT is set (not \overline{ACK}), then the data transfer is complete. In this case, when the not \overline{ACK} is latched by the slave, the slave goes idle and waits for another occurrence of the Start bit. If the SDA line was low (\overline{ACK}), the next transmit data must be loaded into the SSPBUF register. Again, the SCL pin must be released by setting bit CKP.

An MSSP interrupt is generated for each data transfer byte. The SSP1IF bit must be cleared by software and the SSPSTAT register is used to determine the status of the byte. The SSP1IF bit is set on the falling edge of the ninth clock pulse.

20.5.3.1 Slave Mode Bus Collision

A slave receives a Read request and begins shifting data out on the SDA line. If a bus collision is detected and the SBCDE bit of the SSPCON3 register is set, the BCLIF bit of the PIRx register is set. Once a bus collision is detected, the slave goes Idle and waits to be addressed again. User software can use the BCLIF bit to handle a slave bus collision.

20.5.3.2 7-Bit Transmission

A master device can transmit a read request to a slave, and then clock data out of the slave. The list below outlines what software for a slave will need to do to accomplish a standard transmission. [Figure 20-18](#) can be used as a reference to this list.

1. Master sends a Start condition on SDA and SCL.
2. S bit of SSPSTAT is set; SSP1IF is set if interrupt on Start detect is enabled.
3. Matching address with $\overline{R/W}$ bit set is received by the Slave setting SSP1IF bit.
4. Slave hardware generates an \overline{ACK} and sets SSP1IF.
5. SSP1IF bit is cleared by user.
6. Software reads the received address from SSPBUF, clearing BF.
7. $\overline{R/W}$ is set so CKP was automatically cleared after the \overline{ACK} .
8. The slave software loads the transmit data into SSPBUF.
9. CKP bit is set releasing SCL, allowing the master to clock the data out of the slave.
10. SSP1IF is set after the \overline{ACK} response from the master is loaded into the ACKSTAT register.
11. SSP1IF bit is cleared.
12. The slave software checks the ACKSTAT bit to see if the master wants to clock out more data.

Note 1: If the master \overline{ACK} s the clock will be stretched.

2: ACKSTAT is the only bit updated on the rising edge of SCL (9th) rather than the falling.

13. Steps 9-13 are repeated for each transmitted byte.
14. If the master sends a not \overline{ACK} ; the clock is not held, but SSP1IF is still set.
15. The master sends a Restart condition or a Stop.
16. The slave is no longer addressed.

PIC16LF1554/1559

FIGURE 20-18: I²C™ SLAVE, 7-BIT ADDRESS, TRANSMISSION (AHEN = 0)

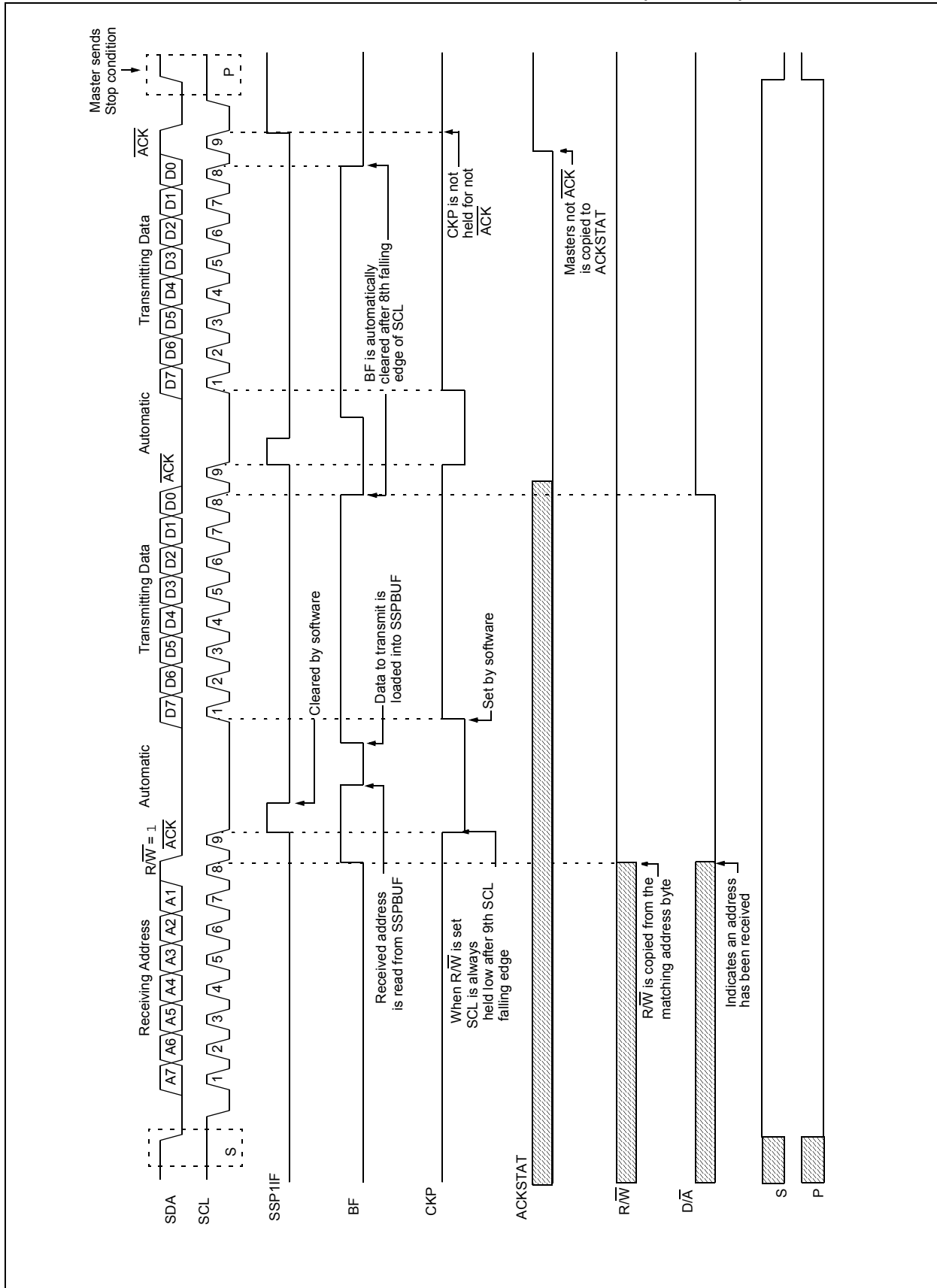

20.5.3.3 7-Bit Transmission with Address Hold Enabled

Setting the AHEN bit of the SSPCON3 register enables additional clock stretching and interrupt generation after the 8th falling edge of a received matching address. Once a matching address has been clocked in, CKP is cleared and the SSP1IF interrupt is set.

Figure 20-19 displays a standard waveform of a 7-bit Address Slave Transmission with AHEN enabled.

1. Bus starts Idle.
2. Master sends Start condition; the S bit of SSPSTAT is set; SSP1IF is set if interrupt on Start detect is enabled.
3. Master sends matching address with $\overline{R/W}$ bit set. After the 8th falling edge of the SCL line the CKP bit is cleared and SSP1IF interrupt is generated.
4. Slave software clears SSP1IF.
5. Slave software reads ACKTIM bit of SSPCON3 register, and $\overline{R/W}$ and $\overline{D/A}$ of the SSPSTAT register to determine the source of the interrupt.
6. Slave reads the address value from the SSPBUF register clearing the BF bit.
7. Slave software decides from this information if it wishes to ACK or not ACK and sets the ACKDT bit of the SSPCON2 register accordingly.
8. Slave sets the CKP bit releasing SCL.
9. Master clocks in the \overline{ACK} value from the slave.
10. Slave hardware automatically clears the CKP bit and sets SSP1IF after the \overline{ACK} if the $\overline{R/W}$ bit is set.
11. Slave software clears SSP1IF.
12. Slave loads value to transmit to the master into SSPBUF setting the BF bit.

Note: SSPBUF cannot be loaded until after the \overline{ACK} .

13. Slave sets CKP bit releasing the clock.
14. Master clocks out the data from the slave and sends an \overline{ACK} value on the 9th SCL pulse.
15. Slave hardware copies the \overline{ACK} value into the ACKSTAT bit of the SSPCON2 register.
16. Steps 10-15 are repeated for each byte transmitted to the master from the slave.
17. If the master sends a not \overline{ACK} the slave releases the bus allowing the master to send a Stop and end the communication.

Note: Master must send a not \overline{ACK} on the last byte to ensure that the slave releases the SCL line to receive a Stop.

PIC16LF1554/1559

FIGURE 20-19: I²C™ SLAVE, 7-BIT ADDRESS, TRANSMISSION (AHEN = 1)

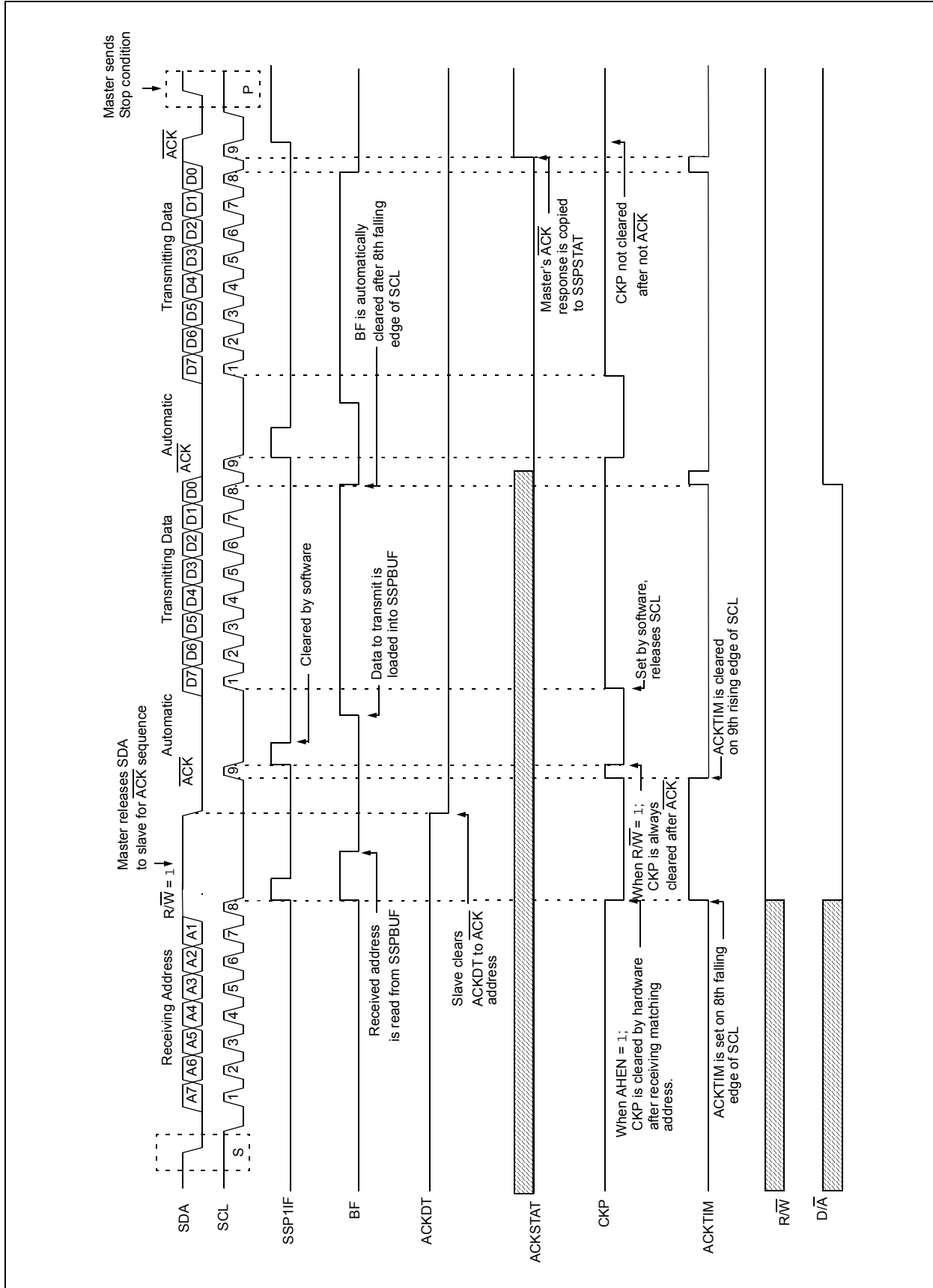

20.5.4 SLAVE MODE 10-BIT ADDRESS RECEPTION

This section describes a standard sequence of events for the MSSP module configured as an I²C Slave in 10-bit Addressing mode.

Figure 20-20 is used as a visual reference for this description.

This is a step by step process of what must be done by slave software to accomplish I²C communication.

1. Bus starts Idle.
2. Master sends Start condition; S bit of SSPSTAT is set; SSP1IF is set if interrupt on Start detect is enabled.
3. Master sends matching high address with R/W bit clear; UA bit of the SSPSTAT register is set.
4. Slave sends $\overline{\text{ACK}}$ and SSP1IF is set.
5. Software clears the SSP1IF bit.
6. Software reads received address from SSPBUF clearing the BF flag.
7. Slave loads low address into SSPADD, releasing SCL.
8. Master sends matching low address byte to the Slave; UA bit is set.

Note: Updates to the SSPADD register are not allowed until after the $\overline{\text{ACK}}$ sequence.

9. Slave sends $\overline{\text{ACK}}$ and SSP1IF is set.

Note: If the low address does not match, SSP1IF and UA are still set so that the slave software can set SSPADD back to the high address. BF is not set because there is no match. CKP is unaffected.

10. Slave clears SSP1IF.
11. Slave reads the received matching address from SSPBUF clearing BF.
12. Slave loads high address into SSPADD.
13. Master clocks a data byte to the slave and clocks out the slaves $\overline{\text{ACK}}$ on the 9th SCL pulse; SSP1IF is set.
14. If SEN bit of SSPCON2 is set, CKP is cleared by hardware and the clock is stretched.
15. Slave clears SSP1IF.
16. Slave reads the received byte from SSPBUF clearing BF.
17. If SEN is set the slave sets CKP to release the SCL.
18. Steps 13-17 repeat for each received byte.
19. Master sends Stop to end the transmission.

20.5.5 10-BIT ADDRESSING WITH ADDRESS OR DATA HOLD

Reception using 10-bit addressing with AHEN or DHEN set is the same as with 7-bit modes. The only difference is the need to update the SSPADD register using the UA bit. All functionality, specifically when the CKP bit is cleared and SCL line is held low are the same. Figure 20-21 can be used as a reference of a slave in 10-bit addressing with AHEN set.

Figure 20-22 shows a standard waveform for a slave transmitter in 10-bit Addressing mode.

PIC16LF1554/1559

FIGURE 20-20: I²C™ SLAVE, 10-BIT ADDRESS, RECEPTION (SEN = 1, AHEN = 0, DHEN = 0)

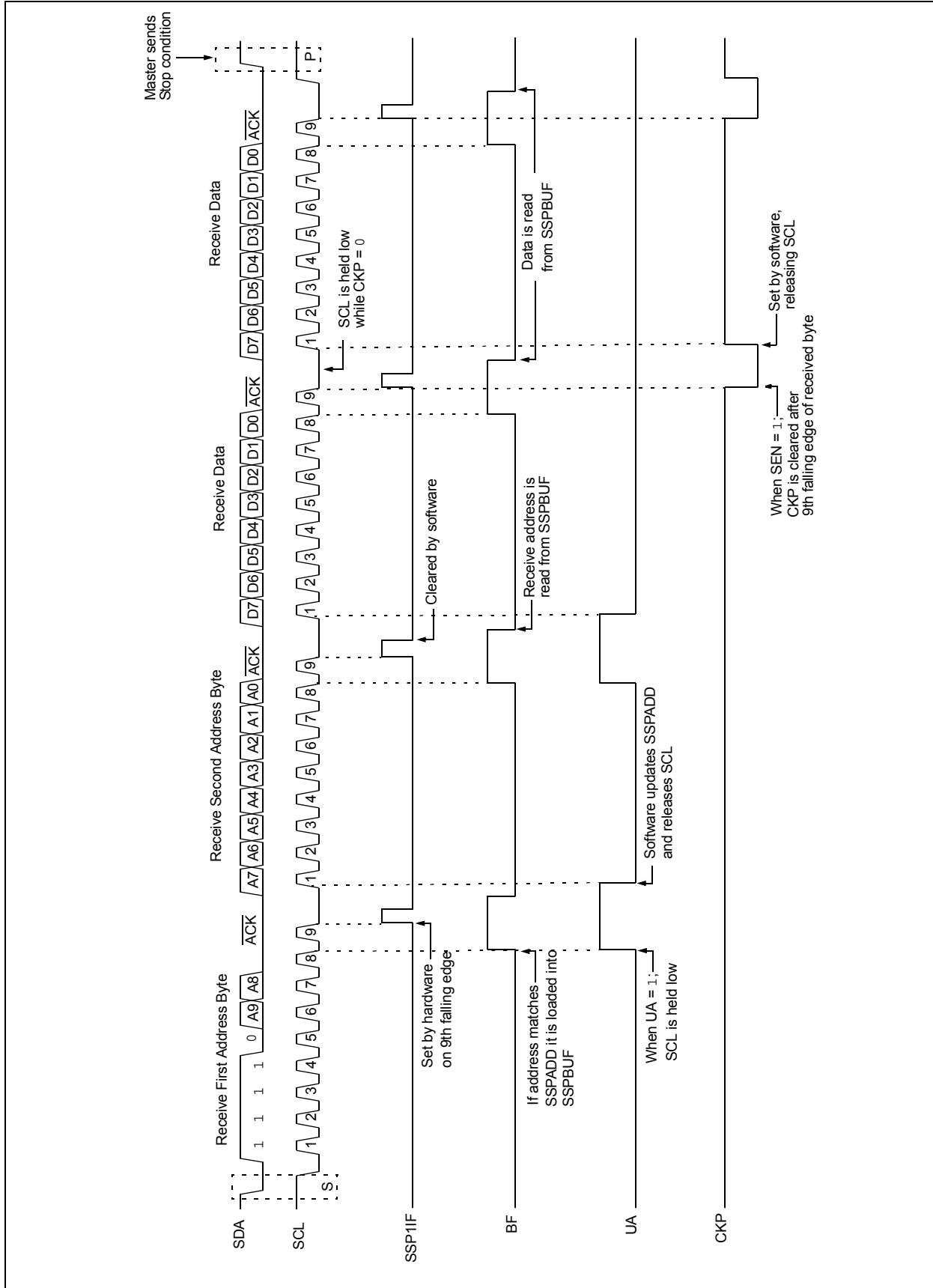
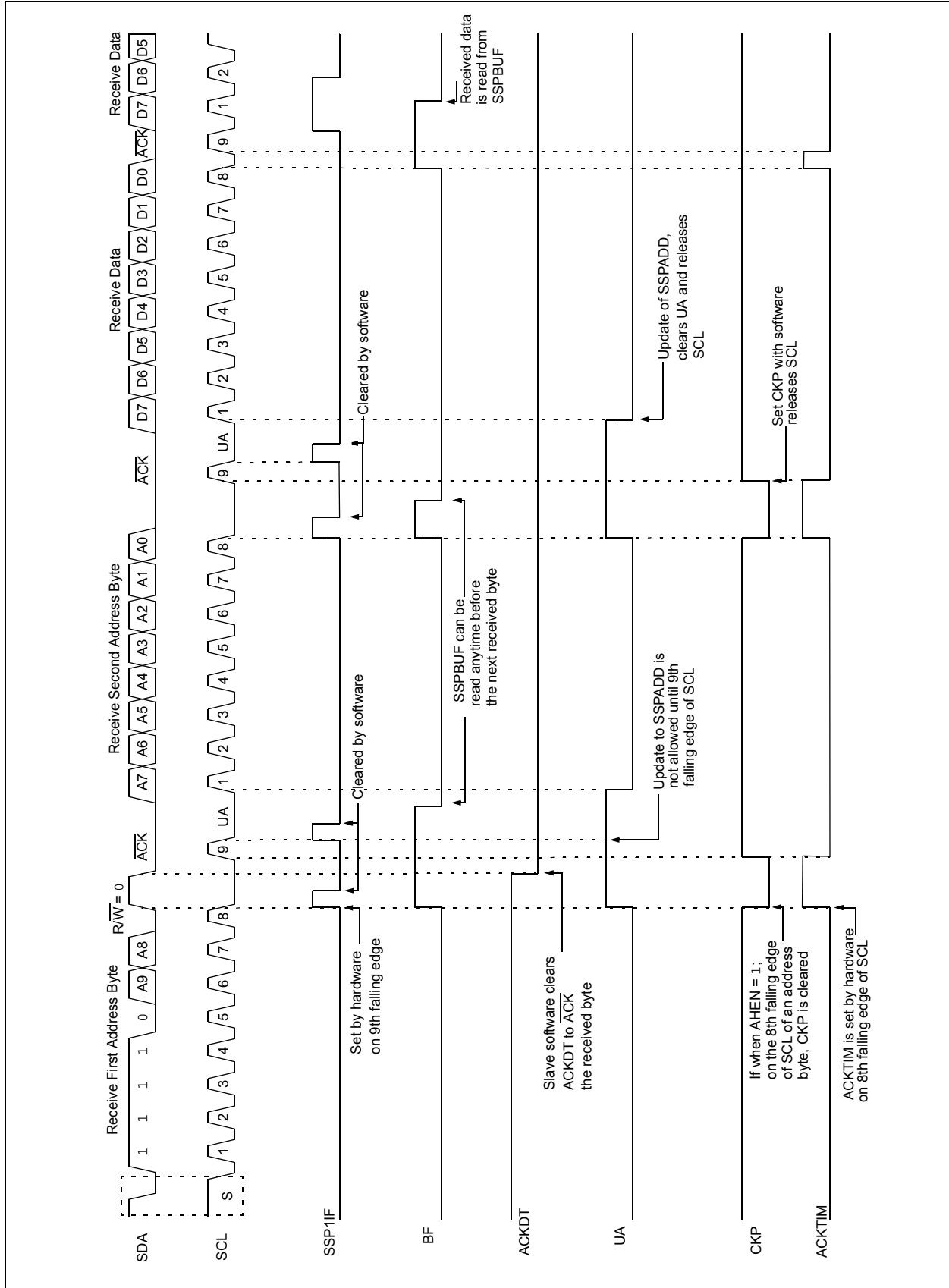
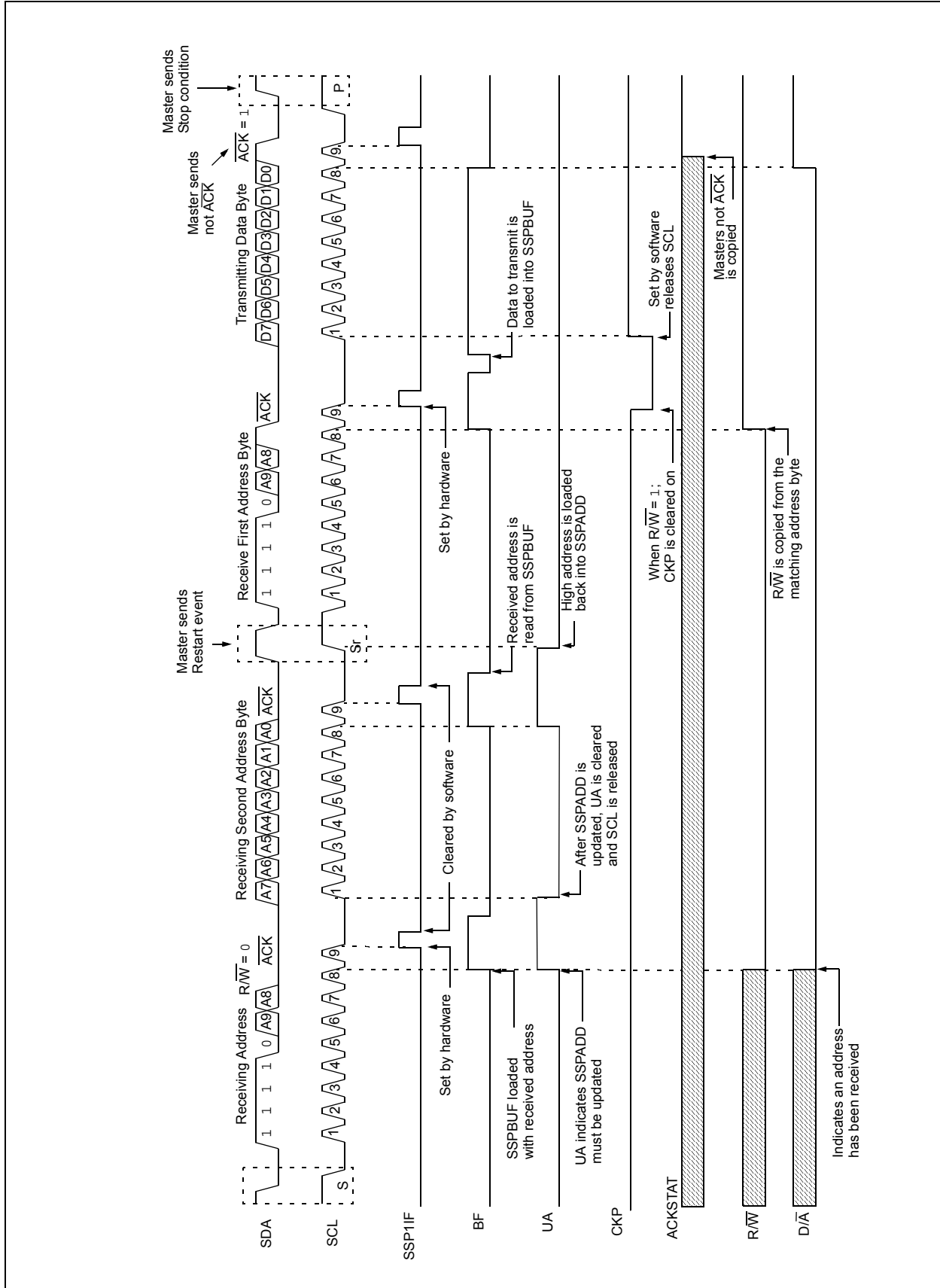

FIGURE 20-21: I²C™ SLAVE, 10-BIT ADDRESS, RECEPTION (SEN = 0, AHEN = 1, DHEN = 0)



PIC16LF1554/1559

FIGURE 20-22: I²C™ SLAVE, 10-BIT ADDRESS, TRANSMISSION (SEN = 0, AHEN = 0, DHEN = 0)



20.5.6 CLOCK STRETCHING

Clock stretching occurs when a device on the bus holds the SCL line low, effectively pausing communication. The slave may stretch the clock to allow more time to handle data or prepare a response for the master device. A master device is not concerned with stretching as anytime it is active on the bus and not transferring data, it is stretching. Any stretching done by a slave is invisible to the master software and handled by the hardware that generates SCL.

The CKP bit of the SSPCON1 register is used to control stretching in software. Any time the CKP bit is cleared, the module will wait for the SCL line to go low and then hold it. Setting CKP will release SCL and allow more communication.

20.5.6.1 Normal Clock Stretching

Following an $\overline{\text{ACK}}$ if the $\text{R}\overline{\text{W}}$ bit of SSPSTAT is set, a read request, the slave hardware will clear CKP. This allows the slave time to update SSPBUF with data to transfer to the master. If the SEN bit of SSPCON2 is set, the slave hardware will always stretch the clock after the ACK sequence. Once the slave is ready; CKP is set by software and communication resumes.

Note 1: The BF bit has no effect on if the clock will be stretched or not. This is different than previous versions of the module that would not stretch the clock, clear CKP, if SSPBUF was read before the 9th falling edge of SCL.

2: Previous versions of the module did not stretch the clock for a transmission if SSPBUF was loaded before the 9th falling edge of SCL. It is now always cleared for read requests.

20.5.6.2 10-Bit Addressing Mode

In 10-bit Addressing mode, when the UA bit is set, the clock is always stretched. This is the only time the SCL is stretched without CKP being cleared. SCL is released immediately after a write to SSPADD.

Note: Previous versions of the module did not stretch the clock if the second address byte did not match.

20.5.6.3 Byte NACKing

When AHEN bit of SSPCON3 is set; CKP is cleared by hardware after the 8th falling edge of SCL for a received matching address byte. When DHEN bit of SSPCON3 is set; CKP is cleared after the 8th falling edge of SCL for received data.

Stretching after the 8th falling edge of SCL allows the slave to look at the received address or data and decide if it wants to ACK the received data.

20.5.7 CLOCK SYNCHRONIZATION AND THE CKP BIT

Any time the CKP bit is cleared, the module will wait for the SCL line to go low and then hold it. However, clearing the CKP bit will not assert the SCL output low until the SCL output is already sampled low. Therefore, the CKP bit will not assert the SCL line until an external I²C master device has already asserted the SCL line. The SCL output will remain low until the CKP bit is set and all other devices on the I²C bus have released SCL. This ensures that a write to the CKP bit will not violate the minimum high time requirement for SCL (see Figure 20-23).

FIGURE 20-23: CLOCK SYNCHRONIZATION TIMING

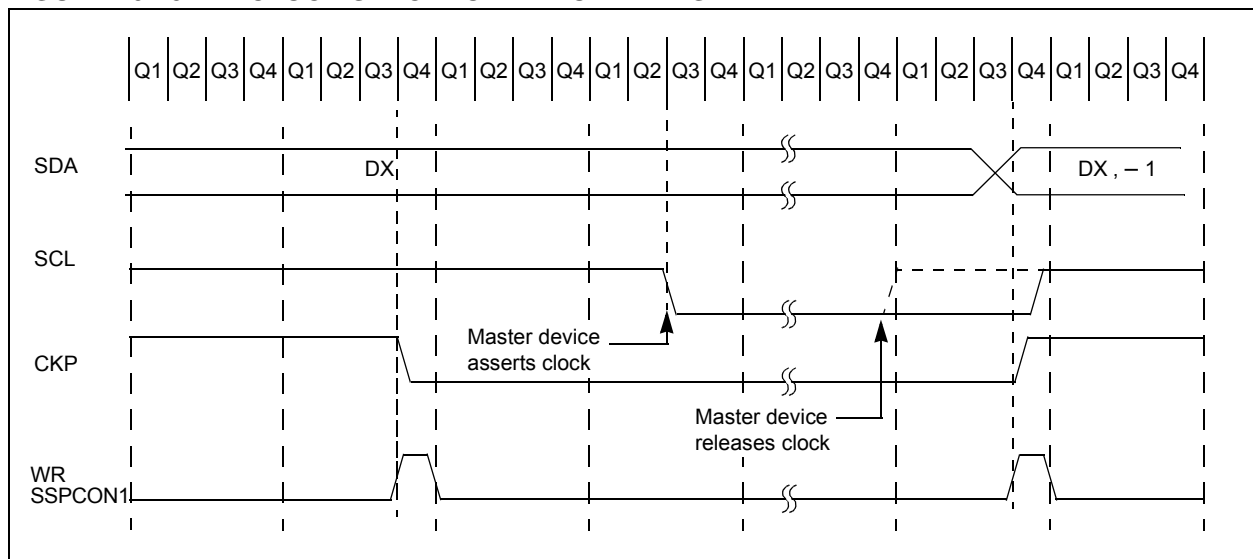

PIC16LF1554/1559

20.5.8 GENERAL CALL ADDRESS SUPPORT

The addressing procedure for the I²C bus is such that the first byte after the Start condition usually determines which device will be the slave addressed by the master device. The exception is the general call address which can address all devices. When this address is used, all devices should, in theory, respond with an acknowledge.

The general call address is a reserved address in the I²C protocol, defined as address 0x00. When the GCEN bit of the SSPCON2 register is set, the slave module will automatically $\overline{\text{ACK}}$ the reception of this address regardless of the value stored in SSPADD. After the slave clocks in an address of all zeros with the R/W bit clear, an interrupt is generated and slave software can read SSPBUF and respond. Figure 20-24 shows a general call reception sequence.

In 10-bit Address mode, the UA bit will not be set on the reception of the general call address. The slave will prepare to receive the second byte as data, just as it would in 7-bit mode.

If the AHEN bit of the SSPCON3 register is set, just as with any other address reception, the slave hardware will stretch the clock after the 8th falling edge of SCL. The slave must then set its ACKDT value and release the clock with communication progressing as it would normally.

FIGURE 20-24: SLAVE MODE GENERAL CALL ADDRESS SEQUENCE

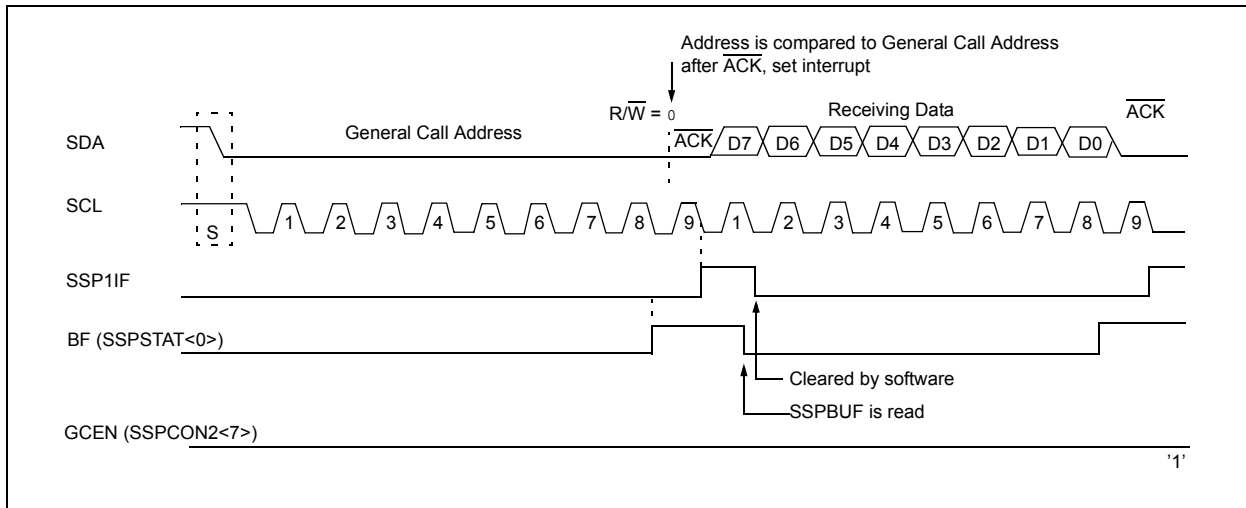

20.5.9 SSP MASK REGISTER

An SSP Mask (SSPMSK) register (Register 20-5) is available in I²C Slave mode as a mask for the value held in the SSPSR register during an address comparison operation. A zero ('0') bit in the SSPMSK register has the effect of making the corresponding bit of the received address a "don't care".

This register is reset to all '1's upon any Reset condition and, therefore, has no effect on standard SSP operation until written with a mask value.

The SSP Mask register is active during:

- 7-bit Address mode: address compare of A<7:1>.
- 10-bit Address mode: address compare of A<7:0> only. The SSP mask has no effect during the reception of the first (high) byte of the address.

20.6 I²C MASTER MODE

Master mode is enabled by setting and clearing the appropriate SSPM bits in the SSPCON1 register and by setting the SSPEN bit. In Master mode, the SDA and SCK pins must be configured as inputs. The MSSP peripheral hardware will override the output driver TRISx controls when necessary to drive the pins low.

Master mode of operation is supported by interrupt generation on the detection of the Start and Stop conditions. The Stop (P) and Start (S) bits are cleared from a Reset or when the MSSP module is disabled. Control of the I²C bus may be taken when the P bit is set, or the bus is Idle.

In Firmware Controlled Master mode, user code conducts all I²C bus operations based on Start and Stop bit condition detection. Start and Stop condition detection is the only active circuitry in this mode. All other communication is done by the user software directly manipulating the SDA and SCL lines.

The following events will cause the SSP interrupt flag bit, SSP1IF, to be set (SSP interrupt, if enabled):

- Start condition detected
- Stop condition detected
- Data transfer byte transmitted/received
- Acknowledge transmitted/received
- Repeated Start generated

Note 1: The MSSP module, when configured in I²C Master mode, does not allow queuing of events. For instance, the user is not allowed to initiate a Start condition and immediately write the SSPBUF register to initiate transmission before the Start condition is complete. In this case, the SSPBUF will not be written to and the WCOL bit will be set, indicating that a write to the SSPBUF did not occur

2: When in Master mode, Start/Stop detection is masked and an interrupt is generated when the SEN/PEN bit is cleared and the generation is complete.

20.6.1 I²C MASTER MODE OPERATION

The master device generates all of the serial clock pulses and the Start and Stop conditions. A transfer is ended with a Stop condition or with a Repeated Start condition. Since the Repeated Start condition is also the beginning of the next serial transfer, the I²C bus will not be released.

In Master Transmitter mode, serial data is output through SDA, while SCL outputs the serial clock. The first byte transmitted contains the slave address of the receiving device (7 bits) and the Read/Write (R/W) bit. In this case, the R/W bit will be logic '0'. Serial data is transmitted eight bits at a time. After each byte is transmitted, an Acknowledge bit is received. Start and Stop conditions are output to indicate the beginning and the end of a serial transfer.

In Master Receive mode, the first byte transmitted contains the slave address of the transmitting device (7 bits) and the R/W bit. In this case, the R/W bit will be logic '1'. Thus, the first byte transmitted is a 7-bit slave address followed by a '1' to indicate the receive bit. Serial data is received via SDA, while SCL outputs the serial clock. Serial data is received eight bits at a time. After each byte is received, an Acknowledge bit is transmitted. Start and Stop conditions indicate the beginning and end of transmission.

A Baud Rate Generator is used to set the clock frequency output on SCL. See [Section 20.7 “Baud Rate Generator”](#) for more detail.

20.6.2 CLOCK ARBITRATION

Clock arbitration occurs when the master, during any receive, transmit or Repeated Start/Stop condition, releases the SCL pin (SCL allowed to float high). When the SCL pin is allowed to float high, the Baud Rate Generator (BRG) is suspended from counting until the SCL pin is actually sampled high. When the SCL pin is sampled high, the Baud Rate Generator is reloaded with the contents of SSPADD and begins counting. This ensures that the SCL high time will always be at least one BRG rollover count in the event that the clock is held low by an external device ([Figure 20-25](#)).

PIC16LF1554/1559

FIGURE 20-25: BAUD RATE GENERATOR TIMING WITH CLOCK ARBITRATION

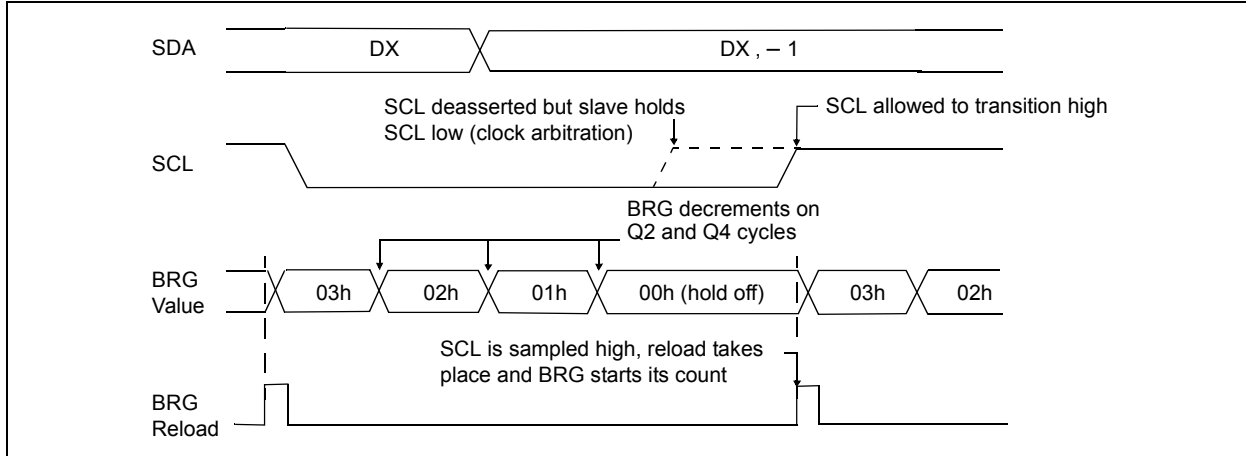

20.6.3 WCOL STATUS FLAG

If the user writes the SSPBUF when a Start, Restart, Stop, Receive or Transmit sequence is in progress, the WCOL bit is set and the contents of the buffer are unchanged (the write does not occur). Any time the WCOL bit is set it indicates that an action on SSPBUF was attempted while the module was not Idle.

Note: Because queuing of events is not allowed, writing to the lower five bits of SSPCON2 is disabled until the Start condition is complete.

Start condition and causes the S bit of the SSPSTAT1 register to be set. Following this, the Baud Rate Generator is reloaded with the contents of SSPADD<7:0> and resumes its count. When the Baud Rate Generator times out (TBRG), the SEN bit of the SSPCON2 register will be automatically cleared by hardware; the Baud Rate Generator is suspended, leaving the SDA line held low and the Start condition is complete.

Note 1: If at the beginning of the Start condition, the SDA and SCL pins are already sampled low, or if during the Start condition, the SCL line is sampled low before the SDA line is driven low, a bus collision occurs, the Bus Collision Interrupt Flag, BCLIF, is set, the Start condition is aborted and the I²C module is reset into its Idle state.

2: The Philips I²C™ Specification states that a bus collision cannot occur on a Start.

20.6.4 I²C MASTER MODE START CONDITION TIMING

To initiate a Start condition (Figure 20-26), the user sets the Start Enable bit, SEN bit of the SSPCON2 register. If the SDA and SCL pins are sampled high, the Baud Rate Generator is reloaded with the contents of SSPADD<7:0> and starts its count. If SCL and SDA are both sampled high when the Baud Rate Generator times out (TBRG), the SDA pin is driven low. The action of the SDA being driven low while SCL is high is the

FIGURE 20-26: FIRST START BIT TIMING

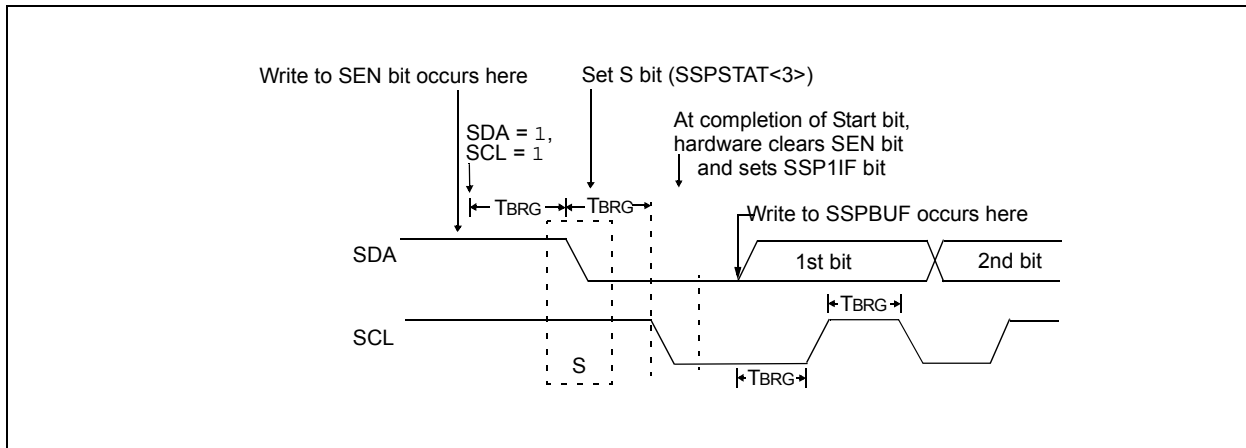

20.6.5 I²C MASTER MODE REPEATED START CONDITION TIMING

A Repeated Start condition (Figure 20-27) occurs when the RSEN bit of the SSPCON2 register is programmed high and the master state machine is no longer active. When the RSEN bit is set, the SCL pin is asserted low. When the SCL pin is sampled low, the Baud Rate Generator is loaded and begins counting. The SDA pin is released (brought high) for one Baud Rate Generator count (TBRG). When the Baud Rate Generator times out, if SDA is sampled high, the SCL pin will be deasserted (brought high). When SCL is sampled high, the Baud Rate Generator is reloaded and begins counting. SDA and SCL must be sampled high for one TBRG. This action is then followed by assertion of the SDA pin (SDA = 0) for one TBRG while SCL is high. SCL is asserted low. Following this, the RSEN bit of the

SSPCON2 register will be automatically cleared and the Baud Rate Generator will not be reloaded, leaving the SDA pin held low. As soon as a Start condition is detected on the SDA and SCL pins, the S bit of the SSPSTAT register will be set. The SSP1IF bit will not be set until the Baud Rate Generator has timed out.

Note 1: If RSEN is programmed while any other event is in progress, it will not take effect.

2: A bus collision during the Repeated Start condition occurs if:

- SDA is sampled low when SCL goes from low-to-high.
- SCL goes low before SDA is asserted low. This may indicate that another master is attempting to transmit a data '1'.

FIGURE 20-27: REPEAT START CONDITION WAVEFORM

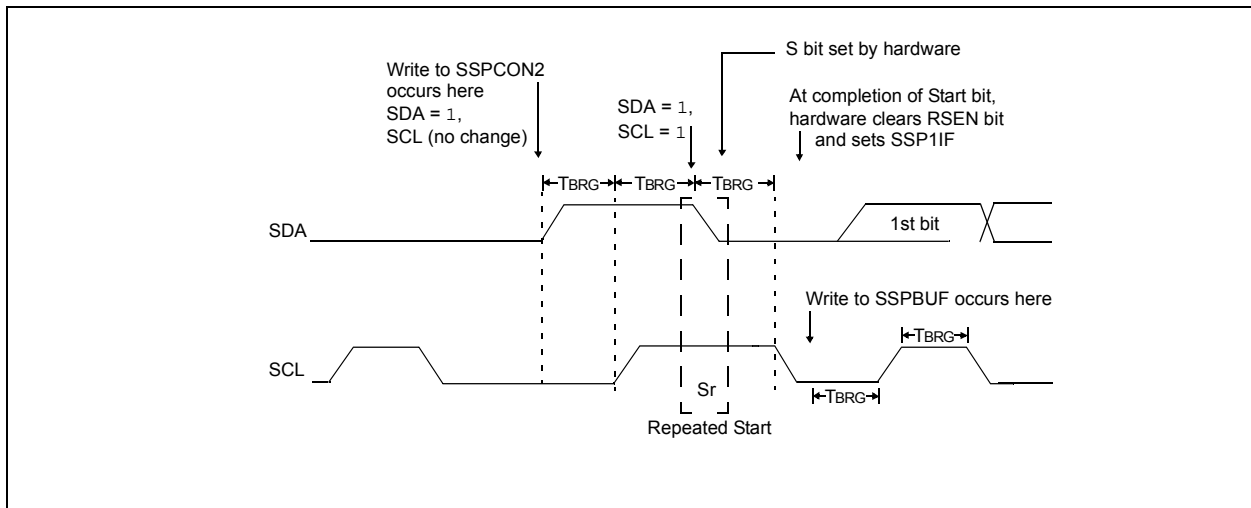

20.6.6 I²C MASTER MODE TRANSMISSION

Transmission of a data byte, a 7-bit address or the other half of a 10-bit address is accomplished by simply writing a value to the SSPBUF register. This action will set the Buffer Full flag bit, BF and allow the Baud Rate Generator to begin counting and start the next transmission. Each bit of address/data will be shifted out onto the SDA pin after the falling edge of SCL is asserted. SCL is held low for one Baud Rate Generator rollover count (TBRG). Data should be valid before SCL is released high. When the SCL pin is released high, it is held that way for TBRG. The data on the SDA pin must remain stable for that duration and some hold time after the next falling edge of SCL. After the eighth bit is shifted out (the falling edge of the eighth clock), the BF flag is cleared and the master releases SDA. This allows the slave device being addressed to respond with an ACK bit during the ninth bit time if an address match occurred, or if data was received properly. The status of ACK is written into the

ACKSTAT bit on the rising edge of the ninth clock. If the master receives an Acknowledge, the Acknowledge Status bit, ACKSTAT, is cleared. If not, the bit is set. After the ninth clock, the SSP1IF bit is set and the master clock (Baud Rate Generator) is suspended until the next data byte is loaded into the SSPBUF, leaving SCL low and SDA unchanged (Figure 20-28).

After the write to the SSPBUF, each bit of the address will be shifted out on the falling edge of SCL until all seven address bits and the R/W bit are completed. On the falling edge of the eighth clock, the master will release the SDA pin, allowing the slave to respond with an Acknowledge. On the falling edge of the ninth clock, the master will sample the SDA pin to see if the address was recognized by a slave. The status of the ACK bit is loaded into the ACKSTAT Status bit of the SSPCON2 register. Following the falling edge of the ninth clock transmission of the address, the SSP1IF is set, the BF flag is cleared and the Baud Rate Generator is turned off until another write to the SSPBUF takes place, holding SCL low and allowing SDA to float.

PIC16LF1554/1559

20.6.6.1 BF Status Flag

In Transmit mode, the BF bit of the SSPSTAT register is set when the CPU writes to SSPBUF and is cleared when all eight bits are shifted out.

20.6.6.2 WCOL Status Flag

If the user writes the SSPBUF when a transmit is already in progress (i.e., SSPSR is still shifting out a data byte), the WCOL bit is set and the contents of the buffer are unchanged (the write does not occur).

WCOL must be cleared by software before the next transmission.

20.6.6.3 ACKSTAT Status Flag

In Transmit mode, the ACKSTAT bit of the SSPCON2 register is cleared when the slave has sent an Acknowledge ($\overline{ACK} = 0$) and is set when the slave does not Acknowledge ($\overline{ACK} = 1$). A slave sends an Acknowledge when it has recognized its address (including a general call), or when the slave has properly received its data.

20.6.6.4 Typical Transmit Sequence

1. The user generates a Start condition by setting the SEN bit of the SSPCON2 register.
2. SSP1IF is set by hardware on completion of the Start.
3. SSP1IF is cleared by software.
4. The MSSP module will wait the required start time before any other operation takes place.
5. The user loads the SSPBUF with the slave address to transmit.
6. Address is shifted out the SDA pin until all eight bits are transmitted. Transmission begins as soon as SSPBUF is written to.
7. The MSSP module shifts in the \overline{ACK} bit from the slave device and writes its value into the ACKSTAT bit of the SSPCON2 register.
8. The MSSP module generates an interrupt at the end of the ninth clock cycle by setting the SSP1IF bit.
9. The user loads the SSPBUF with eight bits of data.
10. Data is shifted out the SDA pin until all eight bits are transmitted.
11. The MSSP module shifts in the \overline{ACK} bit from the slave device and writes its value into the ACKSTAT bit of the SSPCON2 register.
12. Steps 8-11 are repeated for all transmitted data bytes.
13. The user generates a Stop or Restart condition by setting the PEN or RSEN bits of the SSPCON2 register. Interrupt is generated once the Stop/Restart condition is complete.

FIGURE 20-28: I²C™ MASTER MODE WAVEFORM (TRANSMISSION, 7 OR 10-BIT ADDRESS)

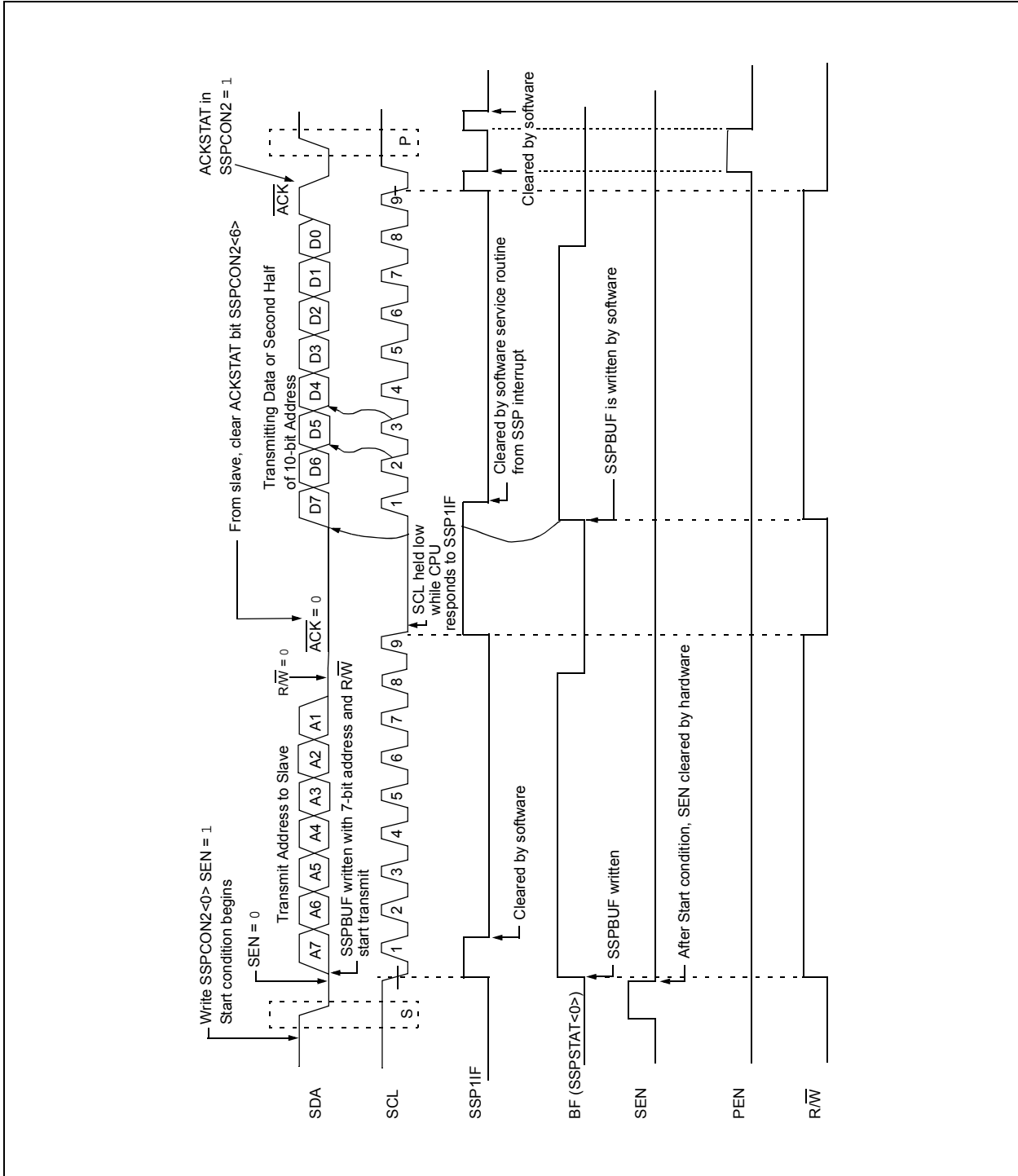

PIC16LF1554/1559

20.6.7 I²C MASTER MODE RECEPTION

Master mode reception (Figure 20-29) is enabled by programming the Receive Enable bit, RCEN bit of the SSPCON2 register.

Note: The MSSP module must be in an Idle state before the RCEN bit is set or the RCEN bit will be disregarded.

The Baud Rate Generator begins counting and on each rollover, the state of the SCL pin changes (high-to-low/low-to-high) and data is shifted into the SSPSR. After the falling edge of the eighth clock, the receive enable flag is automatically cleared, the contents of the SSPSR are loaded into the SSPBUF, the BF flag bit is set, the SSP1IF flag bit is set and the Baud Rate Generator is suspended from counting, holding SCL low. The MSSP is now in Idle state awaiting the next command. When the buffer is read by the CPU, the BF flag bit is automatically cleared. The user can then send an Acknowledge bit at the end of reception by setting the Acknowledge Sequence Enable, ACKEN bit of the SSPCON2 register.

20.6.7.1 BF Status Flag

In receive operation, the BF bit is set when an address or data byte is loaded into SSPBUF from SSPSR. It is cleared when the SSPBUF register is read.

20.6.7.2 SSPOV Status Flag

In receive operation, the SSPOV bit is set when eight bits are received into the SSPSR and the BF flag bit is already set from a previous reception.

20.6.7.3 WCOL Status Flag

If the user writes the SSPBUF when a receive is already in progress (i.e., SSPSR is still shifting in a data byte), the WCOL bit is set and the contents of the buffer are unchanged (the write does not occur).

20.6.7.4 Typical Receive Sequence

1. The user generates a Start condition by setting the SEN bit of the SSPCON2 register.
2. SSP1IF is set by hardware on completion of the Start.
3. SSP1IF is cleared by software.
4. User writes SSPBUF with the slave address to transmit and the R/W bit set.
5. Address is shifted out the SDA pin until all eight bits are transmitted. Transmission begins as soon as SSPBUF is written to.
6. The MSSP module shifts in the \overline{ACK} bit from the slave device and writes its value into the ACKSTAT bit of the SSPCON2 register.
7. The MSSP module generates an interrupt at the end of the ninth clock cycle by setting the SSP1IF bit.
8. User sets the RCEN bit of the SSPCON2 register and the Master clocks in a byte from the slave.
9. After the 8th falling edge of SCL, SSP1IF and BF are set.
10. User clears SSP1IF and reads the received byte from SSPBUF, which clears the BF flag.
11. User either clears the SSPCON2 ACKDT bit to receive another byte or sets the ACKDT bit to suppress further data and then initiates the acknowledge sequence by setting the ACKEN bit.
12. Master's \overline{ACK} or not \overline{ACK} is clocked out to the slave and SSP1IF is set.
13. User clears SSP1IF.
14. Steps 8-13 are repeated for each received byte from the slave.
15. If the ACKDT bit was set in step 11, then the user can send a Stop to release the bus.

FIGURE 20-29: I²C™ MASTER MODE WAVEFORM (RECEPTION, 7-BIT ADDRESS)

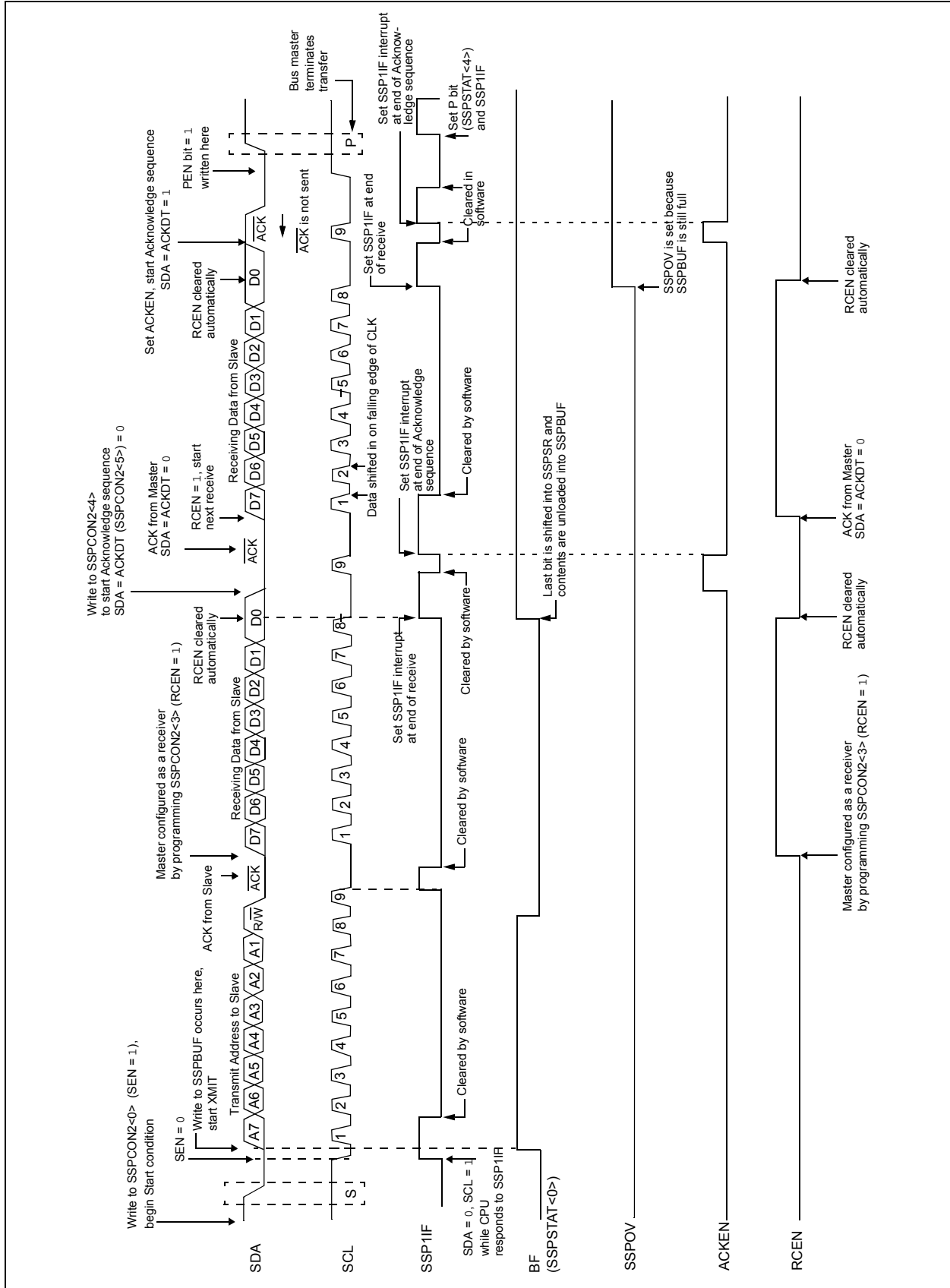

PIC16LF1554/1559

20.6.8 ACKNOWLEDGE SEQUENCE TIMING

An Acknowledge sequence is enabled by setting the Acknowledge Sequence Enable bit, ACKEN bit of the SSPCON2 register. When this bit is set, the SCL pin is pulled low and the contents of the Acknowledge data bit are presented on the SDA pin. If the user wishes to generate an Acknowledge, then the ACKDT bit should be cleared. If not, the user should set the ACKDT bit before starting an Acknowledge sequence. The Baud Rate Generator then counts for one rollover period (TBRG) and the SCL pin is deasserted (pulled high). When the SCL pin is sampled high (clock arbitration), the Baud Rate Generator counts for TBRG. The SCL pin is then pulled low. Following this, the ACKEN bit is automatically cleared, the Baud Rate Generator is turned off and the MSSP module then goes into Idle mode (Figure 20-30).

20.6.8.1 WCOL Status Flag

If the user writes the SSPBUF when an Acknowledge sequence is in progress, then the WCOL bit is set and the contents of the buffer are unchanged (the write does not occur).

20.6.9 STOP CONDITION TIMING

A Stop bit is asserted on the SDA pin at the end of a receive/transmit by setting the Stop Sequence Enable bit, PEN bit of the SSPCON2 register. At the end of a receive/transmit, the SCL line is held low after the falling edge of the ninth clock. When the PEN bit is set, the master will assert the SDA line low. When the SDA line is sampled low, the Baud Rate Generator is reloaded and counts down to '0'. When the Baud Rate Generator times out, the SCL pin will be brought high and one TBRG (Baud Rate Generator rollover count) later, the SDA pin will be deasserted. When the SDA pin is sampled high while SCL is high, the P bit of the SSPSTAT register is set. A TBRG later, the PEN bit is cleared and the SSP1IF bit is set (Figure 20-31).

20.6.9.1 WCOL Status Flag

If the user writes the SSPBUF when a Stop sequence is in progress, then the WCOL bit is set and the contents of the buffer are unchanged (the write does not occur).

FIGURE 20-30: ACKNOWLEDGE SEQUENCE WAVEFORM

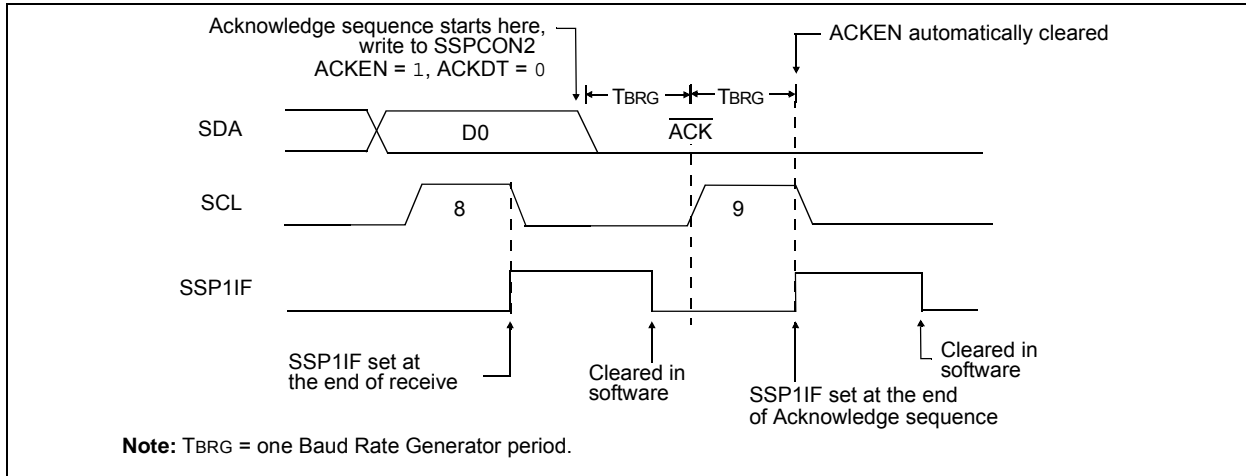
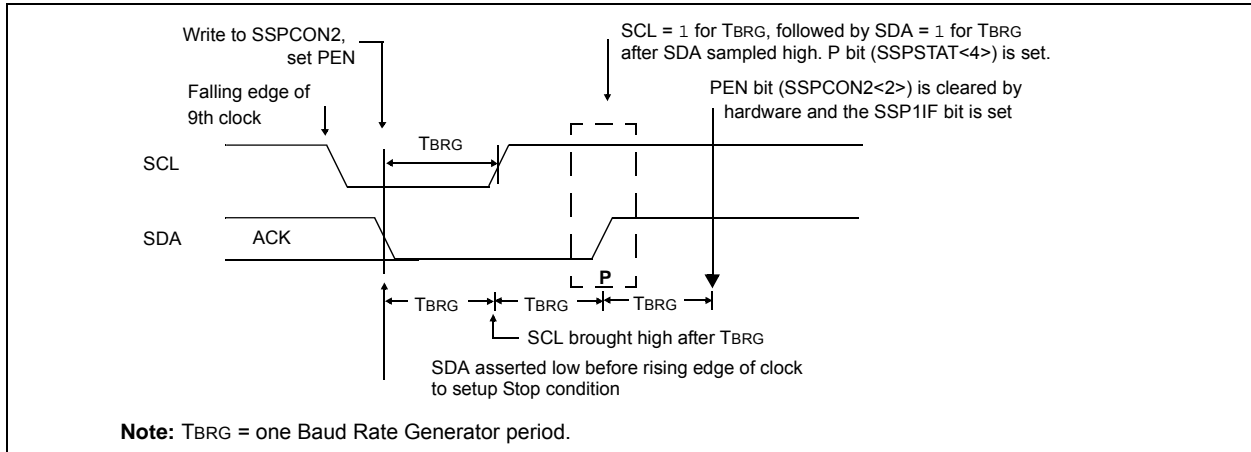

FIGURE 20-31: STOP CONDITION RECEIVE OR TRANSMIT MODE



20.6.10 SLEEP OPERATION

While in Sleep mode, the I²C slave module can receive addresses or data and when an address match or complete byte transfer occurs, wake the processor from Sleep (if the MSSP interrupt is enabled).

20.6.11 EFFECTS OF A RESET

A Reset disables the MSSP module and terminates the current transfer.

20.6.12 MULTI-MASTER MODE

In Multi-Master mode, the interrupt generation on the detection of the Start and Stop conditions allows the determination of when the bus is free. The Stop (P) and Start (S) bits are cleared from a Reset or when the MSSP module is disabled. Control of the I²C bus may be taken when the P bit of the SSPSTAT register is set, or the bus is Idle, with both the S and P bits clear. When the bus is busy, enabling the SSP interrupt will generate the interrupt when the Stop condition occurs.

In multi-master operation, the SDA line must be monitored for arbitration to see if the signal level is the expected output level. This check is performed by hardware with the result placed in the BCLIF bit.

The states where arbitration can be lost are:

- Address Transfer
- Data Transfer
- A Start Condition
- A Repeated Start Condition
- An Acknowledge Condition

20.6.13 MULTI-MASTER COMMUNICATION, BUS COLLISION AND BUS ARBITRATION

Multi-Master mode support is achieved by bus arbitration. When the master outputs address/data bits onto the SDA pin, arbitration takes place when the master outputs a '1' on SDA, by letting SDA float high and another master asserts a '0'. When the SCL pin floats high, data should be stable. If the expected data on SDA is a '1' and the data sampled on the SDA pin is '0', then a bus collision has taken place. The master will set the Bus Collision Interrupt Flag, BCLIF and reset the I²C port to its Idle state (Figure 20-32).

If a transmit was in progress when the bus collision occurred, the transmission is halted, the BF flag is cleared, the SDA and SCL lines are deasserted and the SSPBUF can be written to. When the user services the bus collision Interrupt Service Routine and if the I²C bus is free, the user can resume communication by asserting a Start condition.

If a Start, Repeated Start, Stop or Acknowledge condition was in progress when the bus collision occurred, the condition is aborted, the SDA and SCL lines are deasserted and the respective control bits in the SSPCON2 register are cleared. When the user services the bus collision Interrupt Service Routine and if the I²C bus is free, the user can resume communication by asserting a Start condition.

The master will continue to monitor the SDA and SCL pins. If a Stop condition occurs, the SSP1IF bit will be set.

A write to the SSPBUF will start the transmission of data at the first data bit, regardless of where the transmitter left off when the bus collision occurred.

In Multi-Master mode, the interrupt generation on the detection of Start and Stop conditions allows the determination of when the bus is free. Control of the I²C bus can be taken when the P bit is set in the SSPSTAT register, or the bus is Idle and the S and P bits are cleared.

PIC16LF1554/1559

FIGURE 20-32: BUS COLLISION TIMING FOR TRANSMIT AND ACKNOWLEDGE

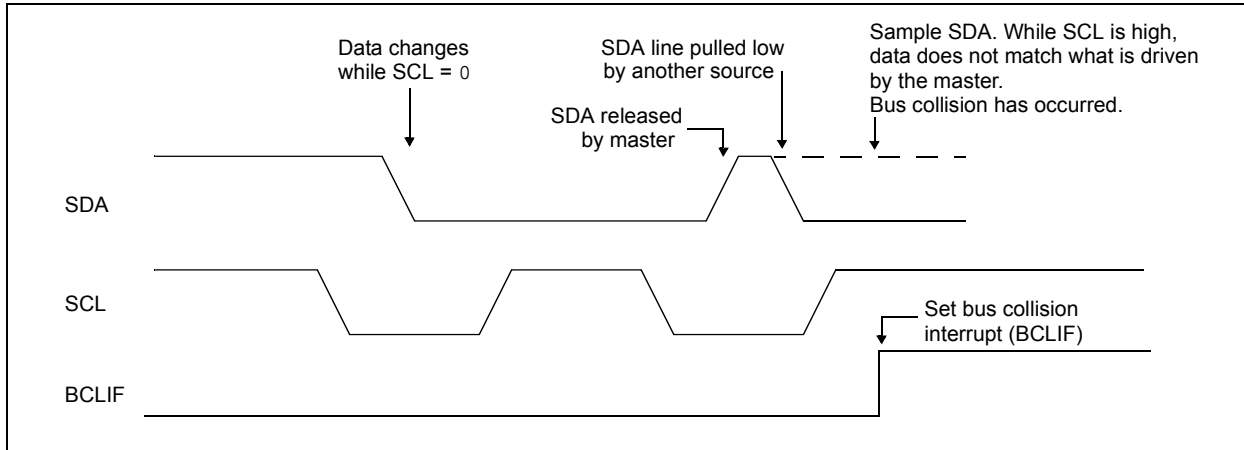

20.6.13.1 Bus Collision During a Start Condition

During a Start condition, a bus collision occurs if:

- SDA or SCL are sampled low at the beginning of the Start condition (Figure 20-33).
- SCL is sampled low before SDA is asserted low (Figure 20-34).

During a Start condition, both the SDA and the SCL pins are monitored.

If the SDA pin is already low, or the SCL pin is already low, then all of the following occur:

- the Start condition is aborted,
- the BCLIF flag is set and
- the MSSP module is reset to its Idle state (Figure 20-33).

The Start condition begins with the SDA and SCL pins deasserted. When the SDA pin is sampled high, the Baud Rate Generator is loaded and counts down. If the SCL pin is sampled low while SDA is high, a bus collision occurs because it is assumed that another master is attempting to drive a data '1' during the Start condition.

If the SDA pin is sampled low during this count, the BRG is reset and the SDA line is asserted early (Figure 20-35). If, however, a '1' is sampled on the SDA pin, the SDA pin is asserted low at the end of the BRG count. The Baud Rate Generator is then reloaded and counts down to zero; if the SCL pin is sampled as '0' during this time, a bus collision does not occur. At the end of the BRG count, the SCL pin is asserted low.

Note: The reason that bus collision is not a factor during a Start condition is that no two bus masters can assert a Start condition at the exact same time. Therefore, one master will always assert SDA before the other. This condition does not cause a bus collision because the two masters must be allowed to arbitrate the first address following the Start condition. If the address is the same, arbitration must be allowed to continue into the data portion, Repeated Start or Stop conditions.

FIGURE 20-33: BUS COLLISION DURING START CONDITION (SDA ONLY)

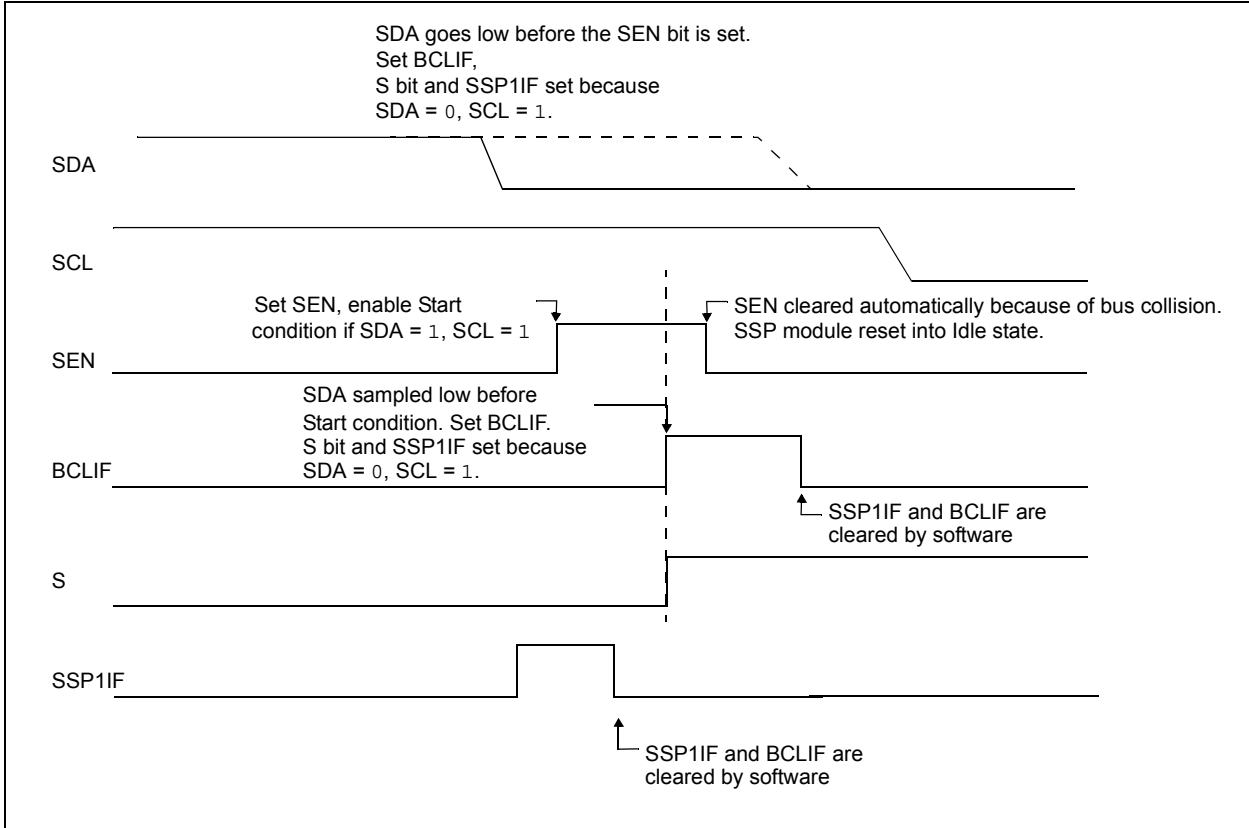
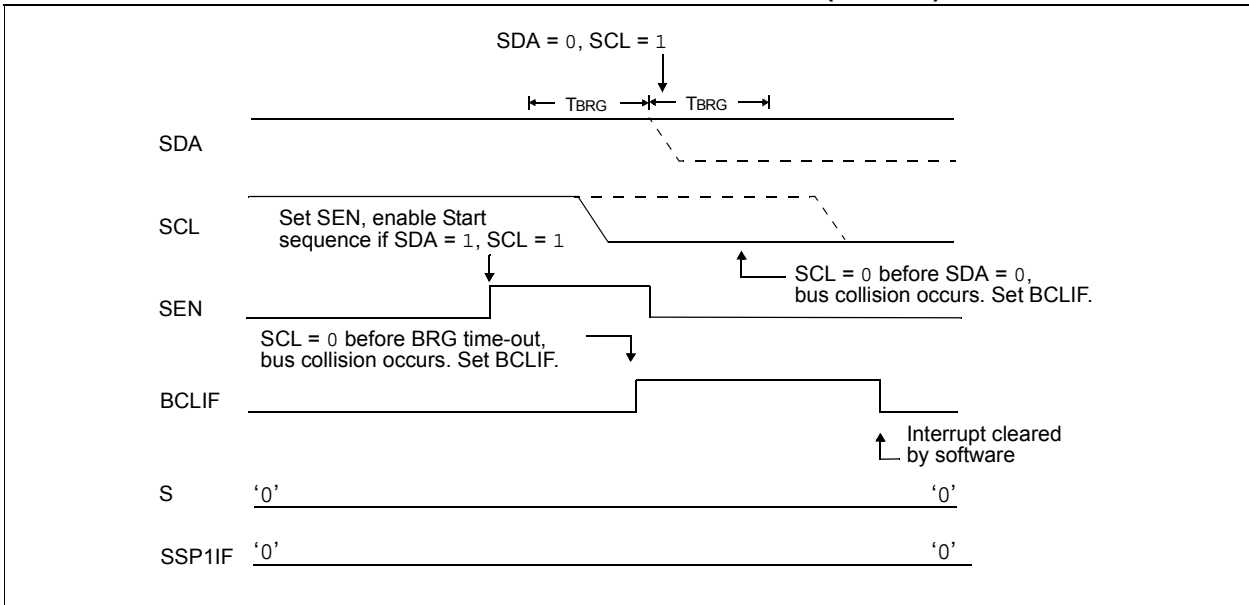
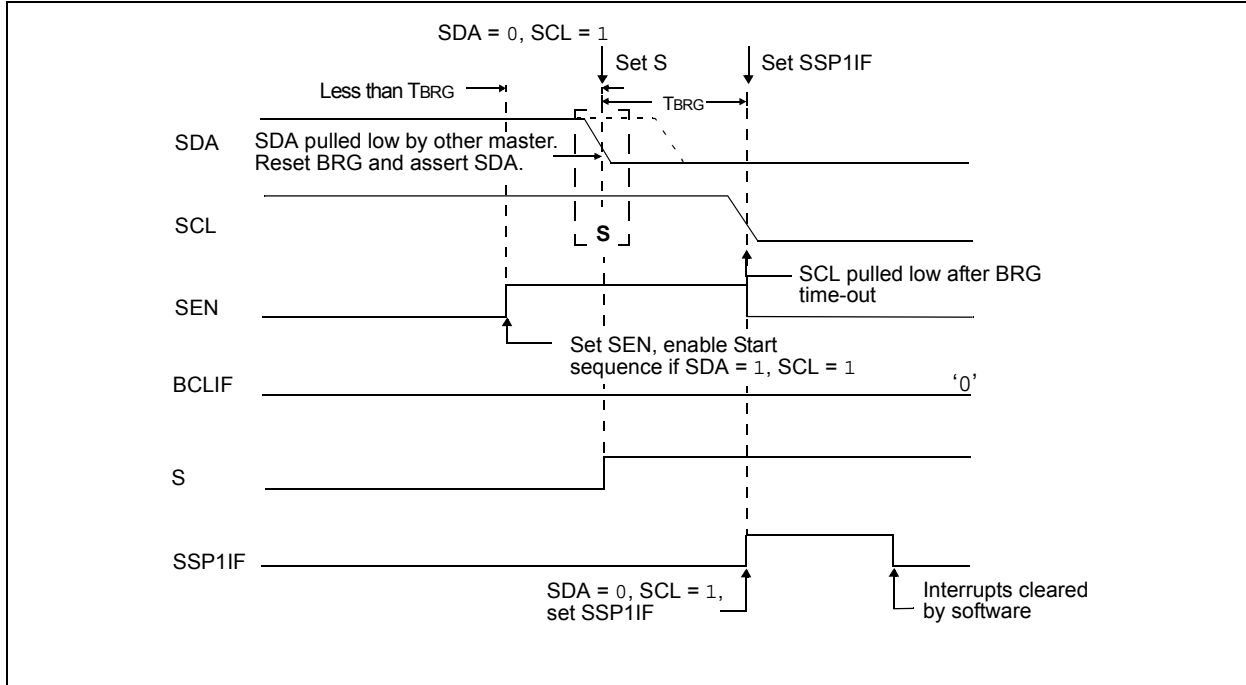

FIGURE 20-34: BUS COLLISION DURING START CONDITION (SCL = 0)



PIC16LF1554/1559

FIGURE 20-35: BRG RESET DUE TO SDA ARBITRATION DURING START CONDITION



20.6.13.2 Bus Collision During a Repeated Start Condition

During a Repeated Start condition, a bus collision occurs if:

- A low level is sampled on SDA when SCL goes from low level to high level (Case 1).
- SCL goes low before SDA is asserted low, indicating that another master is attempting to transmit a data '1' (Case 2).

When the user releases SDA and the pin is allowed to float high, the BRG is loaded with SSPADD and counts down to zero. The SCL pin is then deasserted and when sampled high, the SDA pin is sampled.

If SDA is low, a bus collision has occurred (i.e., another master is attempting to transmit a data '0', [Figure 20-36](#)). If SDA is sampled high, the BRG is reloaded and begins counting. If SDA goes from high-to-low before the BRG times out, no bus collision occurs because no two masters can assert SDA at exactly the same time.

If SCL goes from high-to-low before the BRG times out and SDA has not already been asserted, a bus collision occurs. In this case, another master is attempting to transmit a data '1' during the Repeated Start condition, see [Figure 20-37](#).

If, at the end of the BRG time-out, both SCL and SDA are still high, the SDA pin is driven low and the BRG is reloaded and begins counting. At the end of the count, regardless of the status of the SCL pin, the SCL pin is driven low and the Repeated Start condition is complete.

FIGURE 20-36: BUS COLLISION DURING A REPEATED START CONDITION (CASE 1)

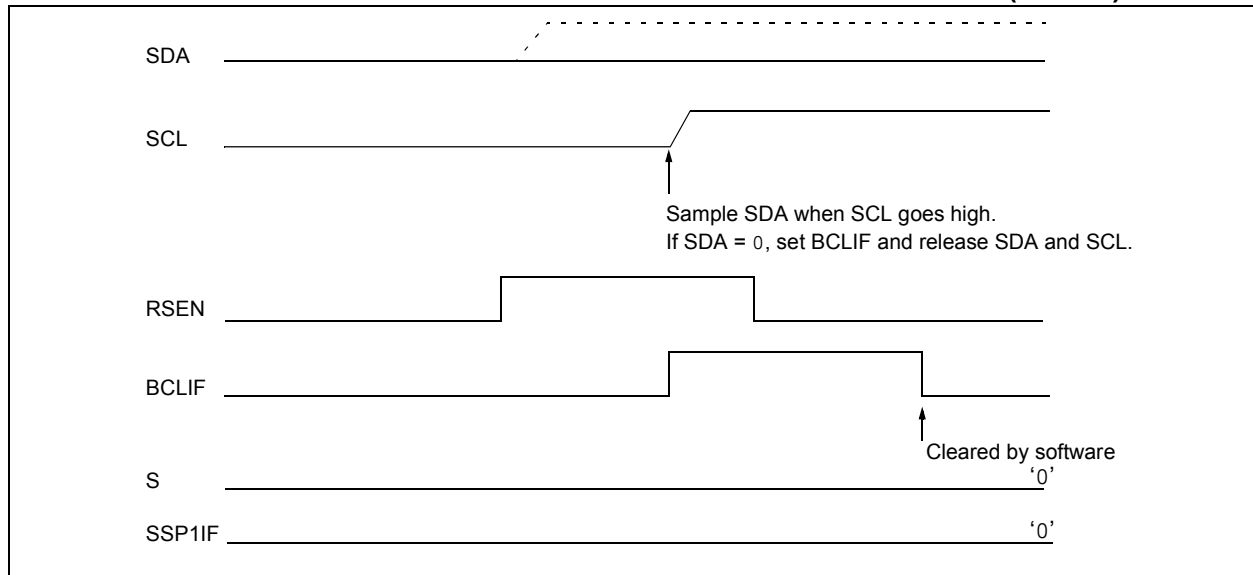
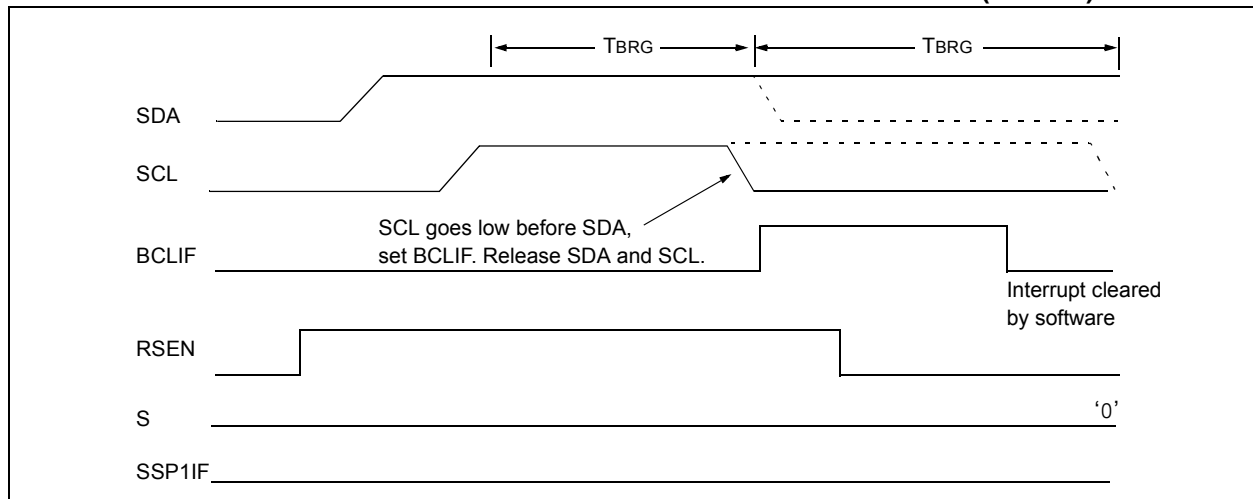

FIGURE 20-37: BUS COLLISION DURING REPEATED START CONDITION (CASE 2)



PIC16LF1554/1559

20.6.13.3 Bus Collision During a Stop Condition

Bus collision occurs during a Stop condition if:

- a) After the SDA pin has been deasserted and allowed to float high, SDA is sampled low after the BRG has timed out (Case 1).
- b) After the SCL pin is deasserted, SCL is sampled low before SDA goes high (Case 2).

The Stop condition begins with SDA asserted low. When SDA is sampled low, the SCL pin is allowed to float. When the pin is sampled high (clock arbitration), the Baud Rate Generator is loaded with SSPADD and counts down to 0. After the BRG times out, SDA is sampled. If SDA is sampled low, a bus collision has occurred. This is due to another master attempting to drive a data '0' (Figure 20-38). If the SCL pin is sampled low before SDA is allowed to float high, a bus collision occurs. This is another case of another master attempting to drive a data '0' (Figure 20-39).

FIGURE 20-38: BUS COLLISION DURING A STOP CONDITION (CASE 1)

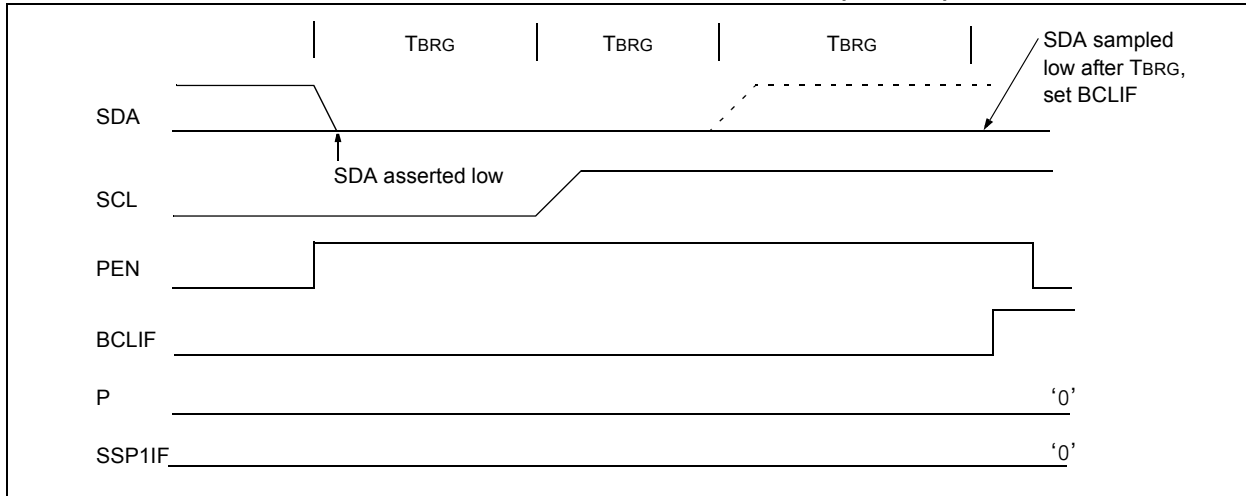

FIGURE 20-39: BUS COLLISION DURING A STOP CONDITION (CASE 2)

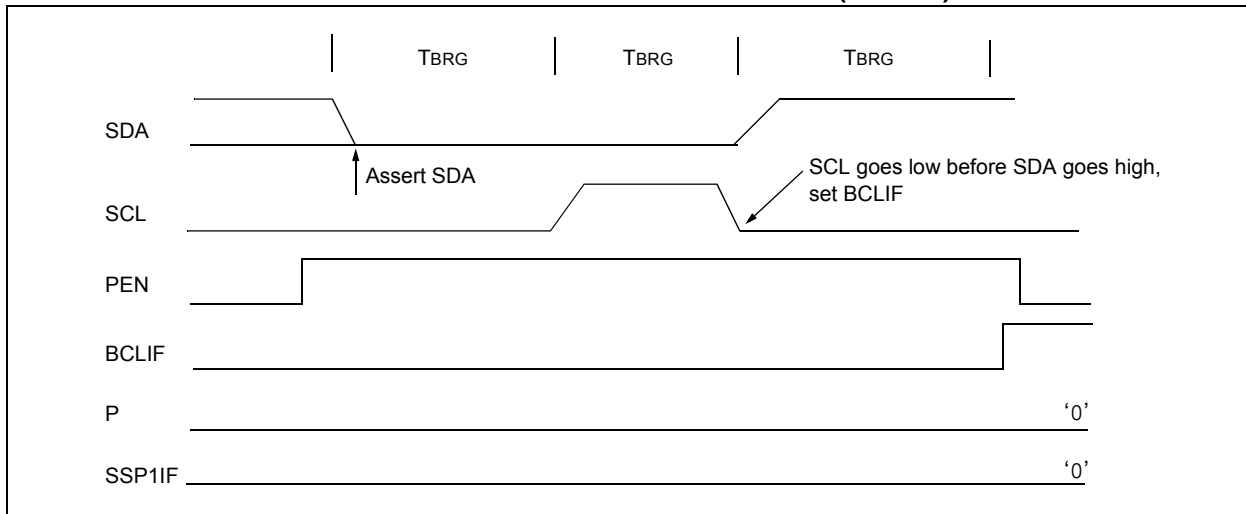

TABLE 20-3: SUMMARY OF REGISTERS ASSOCIATED WITH I²C™ OPERATION

Name	Bit 7	Bit 6	Bit 5	Bit 4	Bit 3	Bit 2	Bit 1	Bit 0	Reset Values on Page:
INTCON	GIE	PEIE	TMR0IE	INTE	IOCIE	TMR0IF	INTF	IOCIF	77
PIE1	TMR1GIE	AD1IE	RCIE	TXIE	SSP1IE	—	TMR2IE	TMR1IE	78
PIE2	—	AD2IE	—	—	BCLIE	—	—	—	79
PIR1	TMR1GIF	AD1IF	RCIF	TXIF	SSP1IF	—	TMR2IF	TMR1IF	80
PIR2	—	AD2IF	—	—	BCLIF	—	—	—	81
SSPADD	ADD<7:0>								233
SSPBUF	Synchronous Serial Port Receive Buffer/Transmit Register								185*
SSPCON1	WCOL	SSPOV	SSPEN	CKP	SSPM<3:0>				230
SSPCON2	GCEN	ACKSTAT	ACKDT	ACKEN	RCEN	PEN	RSEN	SEN	231
SSPCON3	ACKTIM	PCIE	SCIE	BOEN	SDAHT	SBCDE	AHEN	DHEN	232
SSPMSK	MSK<7:0>								233
SSPSTAT	SMP	CKE	D/ \bar{A}	P	S	R/ \bar{W}	UA	BF	229
TRISA	—	—	TRISA5	TRISA4	— ⁽¹⁾	TRISA2	TRISA1	TRISA0	108

Legend: — = unimplemented location, read as '0'. Shaded cells are not used by the MSSP module in I²C™ mode.

* Page provides register information.

Note 1: Unimplemented, read as '1'.

PIC16LF1554/1559

20.7 BAUD RATE GENERATOR

The MSSP module has a Baud Rate Generator available for clock generation in both I²C and SPI Master modes. The Baud Rate Generator (BRG) reload value is placed in the SSPADD register (Register 20-6). When a write occurs to SSPBUF, the Baud Rate Generator will automatically begin counting down.

Once the given operation is complete, the internal clock will automatically stop counting and the clock pin will remain in its last state.

An internal signal “Reload” in Figure 20-40 triggers the value from SSPADD to be loaded into the BRG counter. This occurs twice for each oscillation of the module clock line. The logic dictating when the reload signal is asserted depends on the mode the MSSP is being operated in.

Table 20-4 demonstrates clock rates based on instruction cycles and the BRG value loaded into SSPADD.

EQUATION 20-1:

$$F_{\text{CLOCK}} = \frac{F_{\text{OSC}}}{(\text{SSPxADD} + 1)(4)}$$

FIGURE 20-40: BAUD RATE GENERATOR BLOCK DIAGRAM

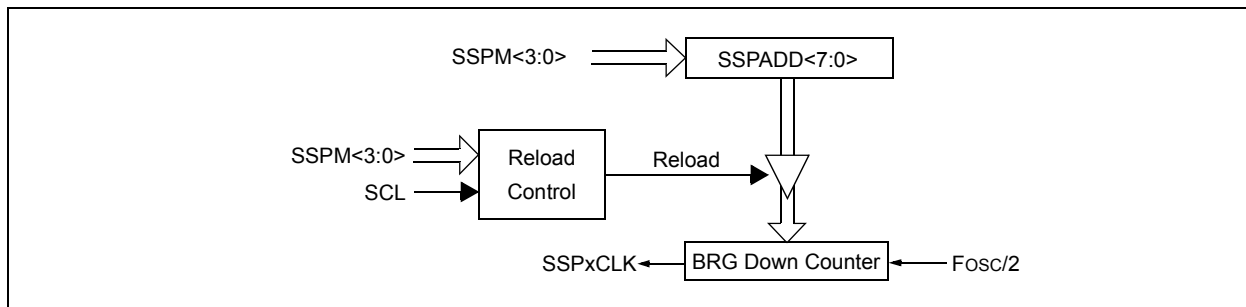

Note: Values of 0x00, 0x01 and 0x02 are not valid for SSPADD when used as a Baud Rate Generator for I²C. This is an implementation limitation.

TABLE 20-4: MSSP CLOCK RATE W/BRG

Fosc	Fcy	BRG Value	F _{CLOCK} (2 Rollovers of BRG)
32 MHz	8 MHz	13h	400 kHz ⁽¹⁾
32 MHz	8 MHz	19h	308 kHz
32 MHz	8 MHz	4Fh	100 kHz
16 MHz	4 MHz	09h	400 kHz ⁽¹⁾
16 MHz	4 MHz	0Ch	308 kHz
16 MHz	4 MHz	27h	100 kHz
4 MHz	1 MHz	09h	100 kHz

Note 1: The I²C™ interface does not conform to the 400 kHz I²C specification (which applies to rates greater than 100 kHz) in all details, but may be used with care where higher rates are required by the application.

20.7.1 ALTERNATE PIN LOCATIONS

This module incorporates I/O pins that can be moved to other locations with the use of the alternate pin function register, APFCON. To determine which pins can be moved and what their default locations are upon a Reset, see Section 11.1 “Alternate Pin Function” for more information.

20.8 Register Definitions: MSSP Control

REGISTER 20-1: SSPSTAT: SSP STATUS REGISTER

R/W-0/0	R/W-0/0	R-0/0	R-0/0	R-0/0	R-0/0	R-0/0	R-0/0
SMP	CKE	D/ \bar{A}	P	S	R/ \bar{W}	UA	BF
bit 7							bit 0

Legend:

R = Readable bit	W = Writable bit	U = Unimplemented bit, read as '0'
u = Bit is unchanged	x = Bit is unknown	-n/n = Value at POR and BOR/Value at all other Resets
'1' = Bit is set	'0' = Bit is cleared	

- bit 7 **SMP:** SPI Data Input Sample bit
SPI Master mode:
 1 = Input data sampled at end of data output time
 0 = Input data sampled at middle of data output time
SPI Slave mode:
 SMP must be cleared when SPI is used in Slave mode
In I²C Master or Slave mode:
 1 = Slew rate control disabled for Standard Speed mode (100 kHz and 1 MHz)
 0 = Slew rate control enabled for High Speed mode (400 kHz)
- bit 6 **CKE:** SPI Clock Edge Select bit (SPI mode only)
In SPI Master or Slave mode:
 1 = Transmit occurs on transition from active to Idle clock state
 0 = Transmit occurs on transition from Idle to active clock state
In I²C™ mode only:
 1 = Enable input logic so that thresholds are compliant with SMBus specification
 0 = Disable SMBus specific inputs
- bit 5 **D/ \bar{A} :** Data/Address bit (I²C™ mode only)
 1 = Indicates that the last byte received or transmitted was data
 0 = Indicates that the last byte received or transmitted was address
- bit 4 **P:** Stop bit
 (I²C mode only. This bit is cleared when the MSSP module is disabled, SSPEN is cleared.)
 1 = Indicates that a Stop bit has been detected last (this bit is '0' on Reset)
 0 = Stop bit was not detected last
- bit 3 **S:** Start bit
 (I²C mode only. This bit is cleared when the MSSP module is disabled, SSPEN is cleared.)
 1 = Indicates that a Start bit has been detected last (this bit is '0' on Reset)
 0 = Start bit was not detected last
- bit 2 **R/ \bar{W} :** Read/Write bit information (I²C mode only)
 This bit holds the R/ \bar{W} bit information following the last address match. This bit is only valid from the address match to the next Start bit, Stop bit, or not ACK bit.
In I²C Slave mode:
 1 = Read
 0 = Write
In I²C Master mode:
 1 = Transmit is in progress
 0 = Transmit is not in progress
 OR-ing this bit with SEN, RSEN, PEN, RCEN or ACKEN will indicate if the MSSP is in Idle mode.
- bit 1 **UA:** Update Address bit (10-bit I²C mode only)
 1 = Indicates that the user needs to update the address in the SSPADD register
 0 = Address does not need to be updated
- bit 0 **BF:** Buffer Full Status bit
Receive (SPI and I²C modes):
 1 = Receive complete, SSPBUF is full
 0 = Receive not complete, SSPBUF is empty
Transmit (I²C mode only):
 1 = Data transmit in progress (does not include the \bar{ACK} and Stop bits), SSPBUF is full
 0 = Data transmit complete (does not include the \bar{ACK} and Stop bits), SSPBUF is empty

PIC16LF1554/1559

REGISTER 20-2: SSPCON1: SSP CONTROL REGISTER 1

R/C/HS-0/0	R/C/HS-0/0	R/W-0/0	R/W-0/0	R/W-0/0	R/W-0/0	R/W-0/0	R/W-0/0
WCOL	SSPOV	SSPEN	CKP	SSPM<3:0>			
bit 7							bit 0

Legend:

R = Readable bit	W = Writable bit	U = Unimplemented bit, read as '0'
u = Bit is unchanged	x = Bit is unknown	-n/n = Value at POR and BOR/Value at all other Resets
'1' = Bit is set	'0' = Bit is cleared	HS = Bit is set by hardware C = User cleared

- bit 7 **WCOL:** Write Collision Detect bit
Master mode:
 1 = A write to the SSPBUF register was attempted while the I²C™ conditions were not valid for a transmission to be started
 0 = No collision
Slave mode:
 1 = The SSPBUF register is written while it is still transmitting the previous word (must be cleared in software)
 0 = No collision
- bit 6 **SSPOV:** Receive Overflow Indicator bit⁽¹⁾
In SPI mode:
 1 = A new byte is received while the SSPBUF register is still holding the previous data. In case of overflow, the data in SSPSR is lost. Overflow can only occur in Slave mode. In Slave mode, the user must read the SSPBUF, even if only transmitting data, to avoid setting overflow. In Master mode, the overflow bit is not set since each new reception (and transmission) is initiated by writing to the SSPBUF register (must be cleared in software).
 0 = No overflow
In I²C mode:
 1 = A byte is received while the SSPBUF register is still holding the previous byte. SSPOV is a "don't care" in Transmit mode (must be cleared in software).
 0 = No overflow
- bit 5 **SSPEN:** Synchronous Serial Port Enable bit
 In both modes, when enabled, these pins must be properly configured as input or output
In SPI mode:
 1 = Enables serial port and configures SCK, SDO, SDI and \overline{SS} as the source of the serial port pins⁽²⁾
 0 = Disables serial port and configures these pins as I/O port pins
In I²C mode:
 1 = Enables the serial port and configures the SDA and SCL pins as the source of the serial port pins⁽³⁾
 0 = Disables serial port and configures these pins as I/O port pins
- bit 4 **CKP:** Clock Polarity Select bit
In SPI mode:
 1 = Idle state for clock is a high level
 0 = Idle state for clock is a low level
In I²C Slave mode:
 SCL release control
 1 = Enable clock
 0 = Holds clock low (clock stretch). Used to ensure data setup time.
In I²C Master mode:
 Unused in this mode
- bit 3-0 **SSPM<3:0>:** Synchronous Serial Port Mode Select bits
 0000 = SPI Master mode, clock = Fosc/4
 0001 = SPI Master mode, clock = Fosc/16
 0010 = SPI Master mode, clock = Fosc/64
 0011 = Reserved
 0100 = SPI Slave mode, clock = SCK pin, \overline{SS} pin control enabled
 0101 = SPI Slave mode, clock = SCK pin, \overline{SS} pin control disabled, \overline{SS} can be used as I/O pin
 0110 = I²C Slave mode, 7-bit address
 0111 = I²C Slave mode, 10-bit address
 1000 = I²C Master mode, clock = Fosc / (4 * (SSPADD+1))⁽⁴⁾
 1001 = Reserved
 1010 = SPI Master mode, clock = Fosc/(4 * (SSPADD+1))⁽⁵⁾
 1011 = I²C firmware controlled Master mode (Slave idle)
 1100 = Reserved
 1101 = Reserved
 1110 = I²C Slave mode, 7-bit address with Start and Stop bit interrupts enabled
 1111 = I²C Slave mode, 10-bit address with Start and Stop bit interrupts enabled

- Note** 1: In Master mode, the overflow bit is not set since each new reception (and transmission) is initiated by writing to the SSPBUF register.
 2: When enabled, these pins must be properly configured as input or output.
 3: When enabled, the SDA and SCL pins must be configured as inputs.
 4: SSPADD values of 0, 1 or 2 are not supported for I²C mode.
 5: SSPADD value of '0' is not supported. Use SSPM = 0000 instead.

REGISTER 20-3: SSPCON2: SSP CONTROL REGISTER 2

R/W-0/0	R-0/0	R/W-0/0	R/S/HS-0/0	R/S/HS-0/0	R/S/HS-0/0	R/S/HS-0/0	R/W/HS-0/0
GCEN	ACKSTAT	ACKDT	ACKEN	RCEN	PEN	RSEN	SEN
bit 7							bit 0

Legend:

R = Readable bit	W = Writable bit	U = Unimplemented bit, read as '0'
u = Bit is unchanged	x = Bit is unknown	-n/n = Value at POR and BOR/Value at all other Resets
'1' = Bit is set	'0' = Bit is cleared	HC = Cleared by hardware S = User set

- bit 7 **GCEN:** General Call Enable bit (in I²C™ Slave mode only)
 1 = Enable interrupt when a general call address (0x00 or 00h) is received in the SSPSR
 0 = General call address disabled
- bit 6 **ACKSTAT:** Acknowledge Status bit (in I²C mode only)
 1 = Acknowledge was not received
 0 = Acknowledge was received
- bit 5 **ACKDT:** Acknowledge Data bit (in I²C mode only)
In Receive mode:
 Value transmitted when the user initiates an Acknowledge sequence at the end of a receive
 1 = Not Acknowledge
 0 = Acknowledge
- bit 4 **ACKEN:** Acknowledge Sequence Enable bit (in I²C Master mode only)⁽¹⁾
In Master Receive mode:
 1 = Initiate Acknowledge sequence on SDA and SCL pins, and transmit ACKDT data bit.
 Automatically cleared by hardware.
 0 = Acknowledge sequence idle
- bit 3 **RCEN:** Receive Enable bit (in I²C Master mode only)⁽¹⁾
 1 = Enables Receive mode for I²C
 0 = Receive idle
- bit 2 **PEN:** Stop Condition Enable bit (in I²C Master mode only)⁽¹⁾
SCK Release Control:
 1 = Initiate Stop condition on SDA and SCL pins. Automatically cleared by hardware.
 0 = Stop condition Idle
- bit 1 **RSEN:** Repeated Start Condition Enable bit (in I²C Master mode only)⁽¹⁾
 1 = Initiate Repeated Start condition on SDA and SCL pins. Automatically cleared by hardware.
 0 = Repeated Start condition Idle
- bit 0 **SEN:** Start Condition Enable/Stretch Enable bit⁽¹⁾
In Master mode:
 1 = Initiate Start condition on SDA and SCL pins. Automatically cleared by hardware.
 0 = Start condition Idle
In Slave mode:
 1 = Clock stretching is enabled for both slave transmit and slave receive (stretch enabled)
 0 = Clock stretching is disabled

Note 1: If the I²C module is not in the Idle mode, this bit may not be set (no spooling) and the SSPBUF may not be written (or writes to the SSPBUF are disabled).

PIC16LF1554/1559

REGISTER 20-4: SSPCON3: SSP CONTROL REGISTER 3

R-0/0	R/W-0/0	R/W-0/0	R/W-0/0	R/W-0/0	R/W-0/0	R/W-0/0	R/W-0/0
ACKTIM	PCIE	SCIE	BOEN	SDAHT	SBCDE	AHEN	DHEN
bit 7							bit 0

Legend:

R = Readable bit	W = Writable bit	U = Unimplemented bit, read as '0'
u = Bit is unchanged	x = Bit is unknown	-n/n = Value at POR and BOR/Value at all other Resets
'1' = Bit is set	'0' = Bit is cleared	

- bit 7 **ACKTIM:** Acknowledge Time Status bit (I²C™ mode only)⁽³⁾
 1 = Indicates the I²C bus is in an Acknowledge sequence, set on eighth falling edge of SCL clock
 0 = Not an Acknowledge sequence, cleared on ninth rising edge of SCL clock
- bit 6 **PCIE:** Stop Condition Interrupt Enable bit (I²C mode only)
 1 = Enable interrupt on detection of Stop condition
 0 = Stop detection interrupts are disabled⁽²⁾
- bit 5 **SCIE:** Start Condition Interrupt Enable bit (I²C mode only)
 1 = Enable interrupt on detection of Start or Restart conditions
 0 = Start detection interrupts are disabled⁽²⁾
- bit 4 **BOEN:** Buffer Overwrite Enable bit
In SPI Slave mode:⁽¹⁾
 1 = SSPBUF updates every time that a new data byte is shifted in ignoring the BF bit
 0 = If new byte is received with BF bit of the SSPSTAT register already set, SSPOV bit of the SSPCON1 register is set, and the buffer is not updated
In I²C Master mode and SPI Master mode:
 This bit is ignored.
In I²C Slave mode:
 1 = SSPBUF is updated and \overline{ACK} is generated for a received address/data byte, ignoring the state of the SSPOV bit only if the BF bit = 0.
 0 = SSPBUF is only updated when SSPOV is clear
- bit 3 **SDAHT:** SDA Hold Time Selection bit (I²C mode only)
 1 = Minimum of 300 ns hold time on SDA after the falling edge of SCL
 0 = Minimum of 100 ns hold time on SDA after the falling edge of SCL
- bit 2 **SBCDE:** Slave Mode Bus Collision Detect Enable bit (I²C Slave mode only)
 If on the rising edge of SCL, SDA is sampled low when the module is outputting a high state, the BCLIF bit of the PIR2 register is set, and bus goes idle
 1 = Enable slave bus collision interrupts
 0 = Slave bus collision interrupts are disabled
- bit 1 **AHEN:** Address Hold Enable bit (I²C Slave mode only)
 1 = Following the eighth falling edge of SCL for a matching received address byte; CKP bit of the SSPCON1 register will be cleared and the SCL will be held low.
 0 = Address holding is disabled
- bit 0 **DHEN:** Data Hold Enable bit (I²C Slave mode only)
 1 = Following the eighth falling edge of SCL for a received data byte; slave hardware clears the CKP bit of the SSPCON1 register and SCL is held low.
 0 = Data holding is disabled

- Note 1:** For daisy-chained SPI operation; allows the user to ignore all but the last received byte. SSPOV is still set when a new byte is received and BF = 1, but hardware continues to write the most recent byte to SSPBUF.
- 2:** This bit has no effect in Slave modes that Start and Stop condition detection is explicitly listed as enabled.
- 3:** The ACKTIM Status bit is only active when the AHEN bit or DHEN bit is set.

REGISTER 20-5: SSPMSK: SSP MASK REGISTER

R/W-1/1	R/W-1/1	R/W-1/1	R/W-1/1	R/W-1/1	R/W-1/1	R/W-1/1	R/W-1/1
MSK<7:0>							
bit 7							bit 0

Legend:

R = Readable bit	W = Writable bit	U = Unimplemented bit, read as '0'
u = Bit is unchanged	x = Bit is unknown	-n/n = Value at POR and BOR/Value at all other Resets
'1' = Bit is set	'0' = Bit is cleared	

- bit 7-1 **MSK<7:1>**: Mask bits
 1 = The received address bit n is compared to SSPADD<n> to detect I²C address match
 0 = The received address bit n is not used to detect I²C address match
- bit 0 **MSK<0>**: Mask bit for I²C Slave mode, 10-bit Address
 I²C Slave mode, 10-bit address (SSPM<3:0> = 0111 or 1111):
 1 = The received address bit 0 is compared to SSPADD<0> to detect I²C address match
 0 = The received address bit 0 is not used to detect I²C address match
 I²C Slave mode, 7-bit address, the bit is ignored

REGISTER 20-6: SSPADD: MSSP ADDRESS AND BAUD RATE REGISTER (I²C™ MODE)

R/W-0/0	R/W-0/0	R/W-0/0	R/W-0/0	R/W-0/0	R/W-0/0	R/W-0/0	R/W-0/0
ADD<7:0>							
bit 7							bit 0

Legend:

R = Readable bit	W = Writable bit	U = Unimplemented bit, read as '0'
u = Bit is unchanged	x = Bit is unknown	-n/n = Value at POR and BOR/Value at all other Resets
'1' = Bit is set	'0' = Bit is cleared	

Master mode:

- bit 7-0 **ADD<7:0>**: Baud Rate Clock Divider bits
 SCL pin clock period = ((ADD<7:0> + 1) * 4) / Fosc

10-Bit Slave mode — Most Significant Address Byte:

- bit 7-3 **Not used:** Unused for Most Significant Address Byte. Bit state of this register is a “don't care”. Bit pattern sent by master is fixed by I²C specification and must be equal to '11110'. However, those bits are compared by hardware and are not affected by the value in this register.
- bit 2-1 **ADD<2:1>**: Two Most Significant bits of 10-bit address
- bit 0 **Not used:** Unused in this mode. Bit state is a “don't care”.

10-Bit Slave mode — Least Significant Address Byte:

- bit 7-0 **ADD<7:0>**: Eight Least Significant bits of 10-bit address

7-Bit Slave mode:

- bit 7-1 **ADD<7:1>**: 7-bit address
- bit 0 **Not used:** Unused in this mode. Bit state is a “don't care”.

PIC16LF1554/1559

21.0 ENHANCED UNIVERSAL SYNCHRONOUS ASYNCHRONOUS RECEIVER TRANSMITTER (EUSART)

The Enhanced Universal Synchronous Asynchronous Receiver Transmitter (EUSART) module is a serial I/O communications peripheral. It contains all the clock generators, shift registers and data buffers necessary to perform an input or output serial data transfer independent of device program execution. The EUSART, also known as a Serial Communications Interface (SCI), can be configured as a full-duplex asynchronous system or half-duplex synchronous system. Full-Duplex mode is useful for communications with peripheral systems, such as CRT terminals and personal computers. Half-Duplex Synchronous mode is intended for communications with peripheral devices, such as ADC or DAC integrated circuits, serial EEPROMs or other microcontrollers. These devices typically do not have internal clocks for baud rate generation and require the external clock signal provided by a master synchronous device.

The EUSART module includes the following capabilities:

- Full-duplex asynchronous transmit and receive
- Two-character input buffer
- One-character output buffer
- Programmable 8-bit or 9-bit character length
- Address detection in 9-bit mode
- Input buffer overrun error detection
- Received character framing error detection
- Half-duplex synchronous master
- Half-duplex synchronous slave
- Programmable clock polarity in synchronous modes
- Sleep operation

The EUSART module implements the following additional features, making it ideally suited for use in Local Interconnect Network (LIN) bus systems:

- Automatic detection and calibration of the baud rate
- Wake-up on Break reception
- 13-bit Break character transmit

Block diagrams of the EUSART transmitter and receiver are shown in [Figure 21-1](#) and [Figure 21-2](#).

The EUSART transmit output (TX_out) is available to the TX/CK pin and internally to the following peripherals:

- Configurable Logic Cell (CLC)

FIGURE 21-1: EUSART TRANSMIT BLOCK DIAGRAM

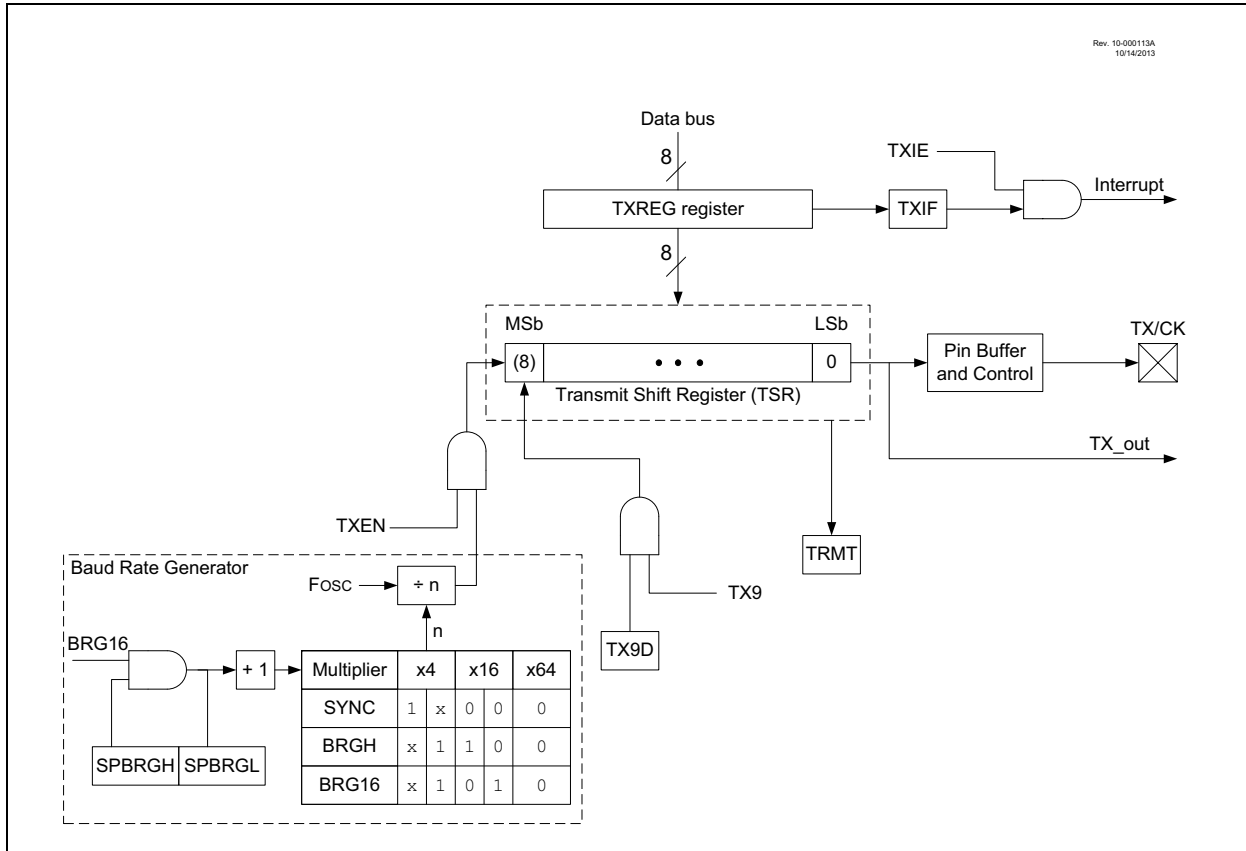
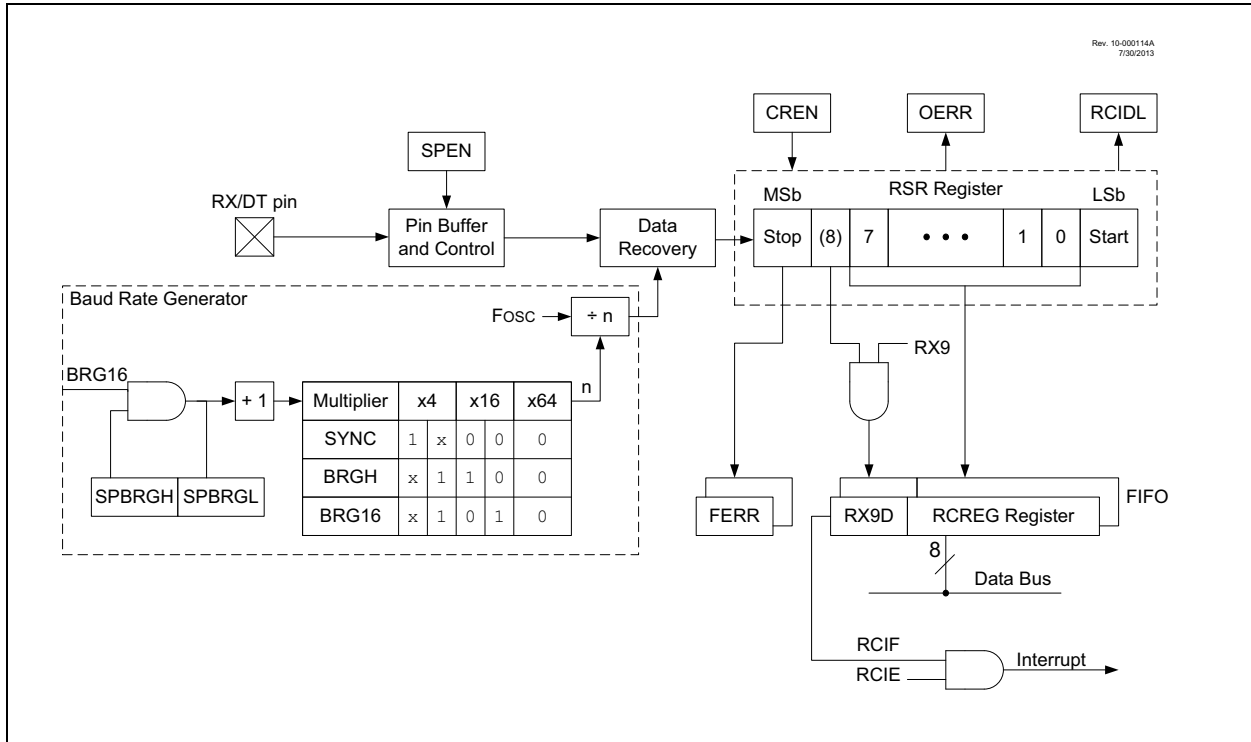

FIGURE 21-2: EUSART RECEIVE BLOCK DIAGRAM



The operation of the EUSART module is controlled through three registers:

- Transmit Status and Control (TXSTA)
- Receive Status and Control (RCSTA)
- Baud Rate Control (BAUDCON)

These registers are detailed in [Register 21-1](#), [Register 21-2](#) and [Register 21-3](#), respectively.

When the receiver or transmitter section is not enabled then the corresponding RX or TX pin may be used for general purpose input and output.

PIC16LF1554/1559

21.1 EUSART Asynchronous Mode

The EUSART transmits and receives data using the standard non-return-to-zero (NRZ) format. NRZ is implemented with two levels: a V_{OH} mark state which represents a '1' data bit, and a V_{OL} space state which represents a '0' data bit. NRZ refers to the fact that consecutively transmitted data bits of the same value stay at the output level of that bit without returning to a neutral level between each bit transmission. An NRZ transmission port idles in the mark state. Each character transmission consists of one Start bit followed by eight or nine data bits and is always terminated by one or more Stop bits. The Start bit is always a space and the Stop bits are always marks. The most common data format is eight bits. Each transmitted bit persists for a period of 1/(Baud Rate). An on-chip dedicated 8-bit/16-bit Baud Rate Generator is used to derive standard baud rate frequencies from the system oscillator. See [Table 21-5](#) for examples of baud rate configurations.

The EUSART transmits and receives the LSb first. The EUSART's transmitter and receiver are functionally independent, but share the same data format and baud rate. Parity is not supported by the hardware, but can be implemented in software and stored as the ninth data bit.

21.1.1 EUSART ASYNCHRONOUS TRANSMITTER

The EUSART transmitter block diagram is shown in [Figure 21-1](#). The heart of the transmitter is the serial Transmit Shift Register (TSR), which is not directly accessible by software. The TSR obtains its data from the transmit buffer, which is the TXREG register.

21.1.1.1 Enabling the Transmitter

The EUSART transmitter is enabled for asynchronous operations by configuring the following three control bits:

- TXEN = 1
- SYNC = 0
- SPEN = 1

All other EUSART control bits are assumed to be in their default state.

Setting the TXEN bit of the TXSTA register enables the transmitter circuitry of the EUSART. Clearing the SYNC bit of the TXSTA register configures the EUSART for asynchronous operation. Setting the SPEN bit of the RCSTA register enables the EUSART and automatically configures the TX/CK I/O pin as an output. If the TX/CK pin is shared with an analog peripheral, the analog I/O function must be disabled by clearing the corresponding ANSELx bit.

Note: The TXIF Transmitter Interrupt flag is set when the TXEN enable bit is set.

21.1.1.2 Transmitting Data

A transmission is initiated by writing a character to the TXREG register. If this is the first character, or the previous character has been completely flushed from the TSR, the data in the TXREG is immediately transferred to the TSR register. If the TSR still contains all or part of a previous character, the new character data is held in the TXREG until the Stop bit of the previous character has been transmitted. The pending character in the TXREG is then transferred to the TSR in one T_{cy} immediately following the Stop bit transmission. The transmission of the Start bit, data bits and Stop bit sequence commences immediately following the transfer of the data to the TSR from the TXREG.

21.1.1.3 Transmit Data Polarity

The polarity of the transmit data can be controlled with the SCKP bit of the BAUDCON register. The default state of this bit is '0' which selects high true transmit idle and data bits. Setting the SCKP bit to '1' will invert the transmit data resulting in low true idle and data bits. The SCKP bit controls transmit data polarity in Asynchronous mode only. In Synchronous mode, the SCKP bit has a different function. See [Section 21.5.1.2 "Clock Polarity"](#).

21.1.1.4 Transmit Interrupt Flag

The TXIF interrupt flag bit of the PIR1 register is set whenever the EUSART transmitter is enabled and no character is being held for transmission in the TXREG. In other words, the TXIF bit is only clear when the TSR is busy with a character and a new character has been queued for transmission in the TXREG. The TXIF flag bit is not cleared immediately upon writing TXREG. TXIF becomes valid in the second instruction cycle following the write execution. Polling TXIF immediately following the TXREG write will return invalid results. The TXIF bit is read-only, it cannot be set or cleared by software.

The TXIF interrupt can be enabled by setting the TXIE interrupt enable bit of the PIE1 register. However, the TXIF flag bit will be set whenever the TXREG is empty, regardless of the state of TXIE enable bit.

To use interrupts when transmitting data, set the TXIE bit only when there is more data to send. Clear the TXIE interrupt enable bit upon writing the last character of the transmission to the TXREG.

21.1.1.5 TSR Status

The TRMT bit of the TXSTA register indicates the status of the TSR register. This is a read-only bit. The TRMT bit is set when the TSR register is empty and is cleared when a character is transferred to the TSR register from the TXREG. The TRMT bit remains clear until all bits have been shifted out of the TSR register. No interrupt logic is tied to this bit, so the user has to poll this bit to determine the TSR status.

Note: The TSR register is not mapped in data memory, so it is not available to the user.

21.1.1.6 Transmitting 9-Bit Characters

The EUSART supports 9-bit character transmissions. When the TX9 bit of the TXSTA register is set, the EUSART will shift nine bits out for each character transmitted. The TX9D bit of the TXSTA register is the ninth, and Most Significant, data bit. When transmitting 9-bit data, the TX9D data bit must be written before writing the eight Least Significant bits into the TXREG. All nine bits of data will be transferred to the TSR shift register immediately after the TXREG is written.

A special 9-bit Address mode is available for use with multiple receivers. See [Section 21.1.2.7 “Address Detection”](#) for more information on the address mode.

21.1.1.7 Asynchronous Transmission Set-up:

1. Initialize the SPBRGH, SPBRGL register pair and the BRGH and BRG16 bits to achieve the desired baud rate (see [Section 21.4 “EUSART Baud Rate Generator \(BRG\)”](#)).
2. Enable the asynchronous serial port by clearing the SYNC bit and setting the SPEN bit.
3. If 9-bit transmission is desired, set the TX9 control bit. A set ninth data bit will indicate that the eight Least Significant data bits are an address when the receiver is set for address detection.
4. Set SCKP bit if inverted transmit is desired.
5. Enable the transmission by setting the TXEN control bit. This will cause the TXIF interrupt bit to be set.
6. If interrupts are desired, set the TXIE interrupt enable bit of the PIE1 register. An interrupt will occur immediately provided that the GIE and PEIE bits of the INTCON register are also set.
7. If 9-bit transmission is selected, the ninth bit should be loaded into the TX9D data bit.
8. Load 8-bit data into the TXREG register. This will start the transmission.

FIGURE 21-3: ASYNCHRONOUS TRANSMISSION

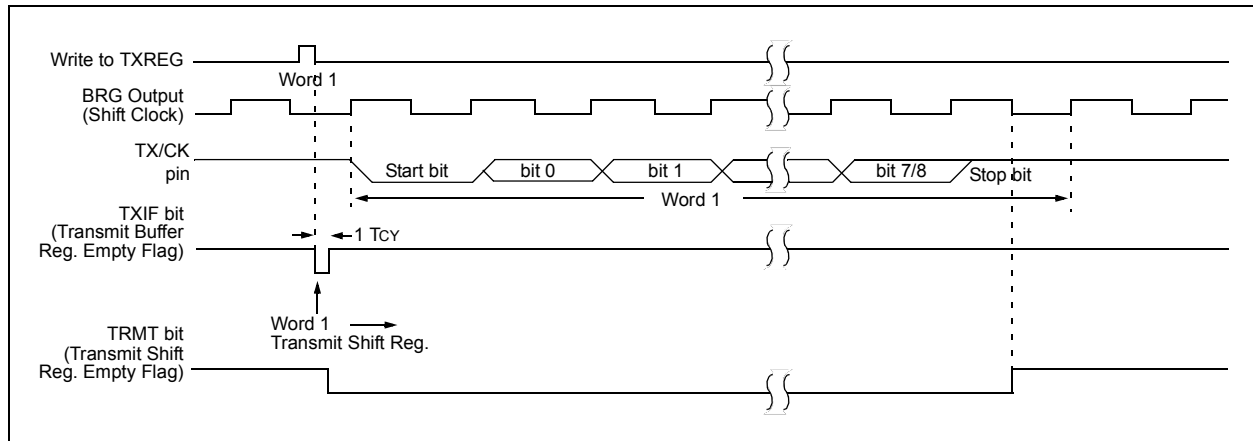

PIC16LF1554/1559

FIGURE 21-4: ASYNCHRONOUS TRANSMISSION (BACK-TO-BACK)

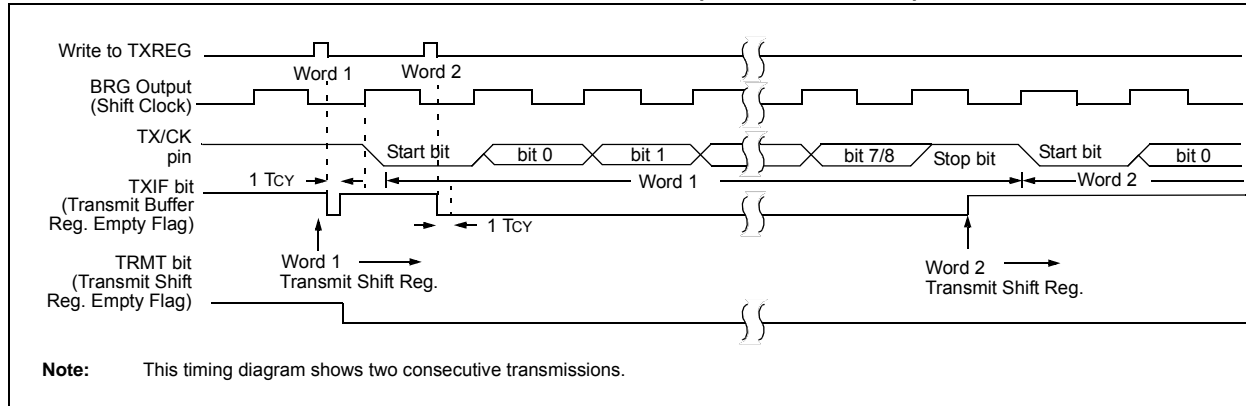

TABLE 21-1: SUMMARY OF REGISTERS ASSOCIATED WITH ASYNCHRONOUS TRANSMISSION

Name	Bit 7	Bit 6	Bit 5	Bit 4	Bit 3	Bit 2	Bit 1	Bit 0	Register on Page
BAUDCON	ABDOVF	RCIDL	—	SCKP	BRG16	—	WUE	ABDEN	245
INTCON	GIE	PEIE	TMR0IE	INTE	IOCIE	TMR0IF	INTF	IOCIF	77
PIE1	TMR1GIE	AD1IE	RCIE	TXIE	SSP1IE	—	TMR2IE	TMR1IE	78
PIR1	TMR1GIF	AD1IF	RCIF	TXIF	SSP1IF	—	TMR2IF	TMR1IF	80
RCSTA	SPEN	RX9	SREN	CREN	ADDEN	FERR	OERR	RX9D	244
SPBRGL	BRG<7:0>								246*
SPBRGH	BRG<15:8>								246*
TRISB	TRISB7	TRISB6	TRISB5	TRISB4	—	—	—	—	112
TXREG	EUSART Transmit Data Register								236
TXSTA	CSRC	TX9	TXEN	SYNC	SENDB	BRGH	TRMT	TX9D	243

Legend: — = unimplemented location, read as '0'. Shaded cells are not used for asynchronous transmission.

* Page provides register information.

21.1.2 EUSART ASYNCHRONOUS RECEIVER

The Asynchronous mode is typically used in RS-232 systems. The receiver block diagram is shown in [Figure 21-2](#). The data is received on the RX/DT pin and drives the data recovery block. The data recovery block is actually a high-speed shifter operating at 16 times the baud rate, whereas the serial Receive Shift Register (RSR) operates at the bit rate. When all eight or nine bits of the character have been shifted in, they are immediately transferred to a two character First-In-First-Out (FIFO) memory. The FIFO buffering allows reception of two complete characters and the start of a third character before software must start servicing the EUSART receiver. The FIFO and RSR registers are not directly accessible by software. Access to the received data is via the RCREG register.

21.1.2.1 Enabling the Receiver

The EUSART receiver is enabled for asynchronous operation by configuring the following three control bits:

- CREN = 1
- SYNC = 0
- SPEN = 1

All other EUSART control bits are assumed to be in their default state.

Setting the CREN bit of the RCSTA register enables the receiver circuitry of the EUSART. Clearing the SYNC bit of the TXSTA register configures the EUSART for asynchronous operation. Setting the SPEN bit of the RCSTA register enables the EUSART. The programmer must set the corresponding TRISx bit to configure the RX/DT I/O pin as an input.

Note: If the RX/DT function is on an analog pin, the corresponding ANSELx bit must be cleared for the receiver to function.

21.1.2.2 Receiving Data

The receiver data recovery circuit initiates character reception on the falling edge of the first bit. The first bit, also known as the Start bit, is always a zero. The data recovery circuit counts one-half bit time to the center of the Start bit and verifies that the bit is still a zero. If it is not a zero then the data recovery circuit aborts character reception, without generating an error, and resumes looking for the falling edge of the Start bit. If the Start bit zero verification succeeds then the data recovery circuit counts a full bit time to the center of the next bit. The bit is then sampled by a majority detect circuit and the resulting '0' or '1' is shifted into the RSR. This repeats until all data bits have been sampled and shifted into the RSR. One final bit time is measured and the level sampled. This is the Stop bit, which is always a '1'. If the data recovery circuit samples a '0' in the Stop bit position then a framing error is set for this character, otherwise the framing error is cleared for this character. See [Section 21.1.2.4 "Receive Framing Error"](#) for more information on framing errors.

Immediately after all data bits and the Stop bit have been received, the character in the RSR is transferred to the EUSART receive FIFO and the RCIF interrupt flag bit of the PIR1 register is set. The top character in the FIFO is transferred out of the FIFO by reading the RCREG register.

Note: If the receive FIFO is overrun, no additional characters will be received until the overrun condition is cleared. See [Section 21.1.2.5 "Receive Overrun Error"](#) for more information on overrun errors.

21.1.2.3 Receive Interrupts

The RCIF interrupt flag bit of the PIR1 register is set whenever the EUSART receiver is enabled and there is an unread character in the receive FIFO. The RCIF interrupt flag bit is read-only, it cannot be set or cleared by software.

RCIF interrupts are enabled by setting all of the following bits:

- RCIE, Interrupt Enable bit of the PIE1 register
- PEIE, Peripheral Interrupt Enable bit of the INTCON register
- GIE, Global Interrupt Enable bit of the INTCON register

The RCIF interrupt flag bit will be set when there is an unread character in the FIFO, regardless of the state of interrupt enable bits.

PIC16LF1554/1559

21.1.2.4 Receive Framing Error

Each character in the receive FIFO buffer has a corresponding framing error Status bit. A framing error indicates that a Stop bit was not seen at the expected time. The framing error status is accessed via the FERR bit of the RCSTA register. The FERR bit represents the status of the top unread character in the receive FIFO. Therefore, the FERR bit must be read before reading the RCREG.

The FERR bit is read-only and only applies to the top unread character in the receive FIFO. A framing error (FERR = 1) does not preclude reception of additional characters. It is not necessary to clear the FERR bit. Reading the next character from the FIFO buffer will advance the FIFO to the next character and the next corresponding framing error.

The FERR bit can be forced clear by clearing the SPEN bit of the RCSTA register, which resets the EUSART. Clearing the CREN bit of the RCSTA register does not affect the FERR bit. A framing error by itself does not generate an interrupt.

Note: If all receive characters in the receive FIFO have framing errors, repeated reads of the RCREG will not clear the FERR bit.
--

21.1.2.5 Receive Overrun Error

The receive FIFO buffer can hold two characters. An overrun error will be generated if a third character, in its entirety, is received before the FIFO is accessed. When this happens the OERR bit of the RCSTA register is set. The characters already in the FIFO buffer can be read but no additional characters will be received until the error is cleared. The error must be cleared by either clearing the CREN bit of the RCSTA register or by resetting the EUSART by clearing the SPEN bit of the RCSTA register.

21.1.2.6 Receiving 9-Bit Characters

The EUSART supports 9-bit character reception. When the RX9 bit of the RCSTA register is set, the EUSART will shift nine bits into the RSR for each character received. The RX9D bit of the RCSTA register is the ninth and Most Significant data bit of the top unread character in the receive FIFO. When reading 9-bit data from the receive FIFO buffer, the RX9D data bit must be read before reading the eight Least Significant bits from the RCREG.

21.1.2.7 Address Detection

A special Address Detection mode is available for use when multiple receivers share the same transmission line, such as in RS-485 systems. Address detection is enabled by setting the ADDEN bit of the RCSTA register.

Address detection requires 9-bit character reception. When address detection is enabled, only characters with the ninth data bit set will be transferred to the receive FIFO buffer, thereby setting the RCIF interrupt bit. All other characters will be ignored.

Upon receiving an address character, user software determines if the address matches its own. Upon address match, user software must disable address detection by clearing the ADDEN bit before the next Stop bit occurs. When user software detects the end of the message, determined by the message protocol used, software places the receiver back into the Address Detection mode by setting the ADDEN bit.

21.1.2.8 Asynchronous Reception Set-up:

1. Initialize the SPBRGH, SPBRGL register pair and the BRGH and BRG16 bits to achieve the desired baud rate (see [Section 21.4 “EUSART Baud Rate Generator \(BRG\)”](#)).
2. Clear the ANSELx bit for the RX pin (if applicable).
3. Enable the serial port by setting the SPEN bit. The SYNC bit must be clear for asynchronous operation.
4. If interrupts are desired, set the RCIE bit of the PIE1 register and the GIE and PEIE bits of the INTCON register.
5. If 9-bit reception is desired, set the RX9 bit.
6. Enable reception by setting the CREN bit.
7. The RCIF interrupt flag bit will be set when a character is transferred from the RSR to the receive buffer. An interrupt will be generated if the RCIE interrupt enable bit was also set.
8. Read the RCSTA register to get the error flags and, if 9-bit data reception is enabled, the ninth data bit.
9. Get the received eight Least Significant data bits from the receive buffer by reading the RCREG register.
10. If an overrun occurred, clear the OERR flag by clearing the CREN receiver enable bit.

21.1.2.9 9-Bit Address Detection Mode Set-up

This mode would typically be used in RS-485 systems. To set up an asynchronous reception with address detect enable:

1. Initialize the SPBRGH, SPBRGL register pair and the BRGH and BRG16 bits to achieve the desired baud rate (see [Section 21.4 “EUSART Baud Rate Generator \(BRG\)”](#)).
2. Clear the ANSELx bit for the RX pin (if applicable).
3. Enable the serial port by setting the SPEN bit. The SYNC bit must be clear for asynchronous operation.
4. If interrupts are desired, set the RCIE bit of the PIE1 register and the GIE and PEIE bits of the INTCON register.
5. Enable 9-bit reception by setting the RX9 bit.
6. Enable address detection by setting the ADDEN bit.
7. Enable reception by setting the CREN bit.
8. The RCIF interrupt flag bit will be set when a character with the ninth bit set is transferred from the RSR to the receive buffer. An interrupt will be generated if the RCIE interrupt enable bit was also set.
9. Read the RCSTA register to get the error flags. The ninth data bit will always be set.
10. Get the received eight Least Significant data bits from the receive buffer by reading the RCREG register. Software determines if this is the device's address.
11. If an overrun occurred, clear the OERR flag by clearing the CREN receiver enable bit.
12. If the device has been addressed, clear the ADDEN bit to allow all received data into the receive buffer and generate interrupts.

PIC16LF1554/1559

FIGURE 21-5: ASYNCHRONOUS RECEPTION

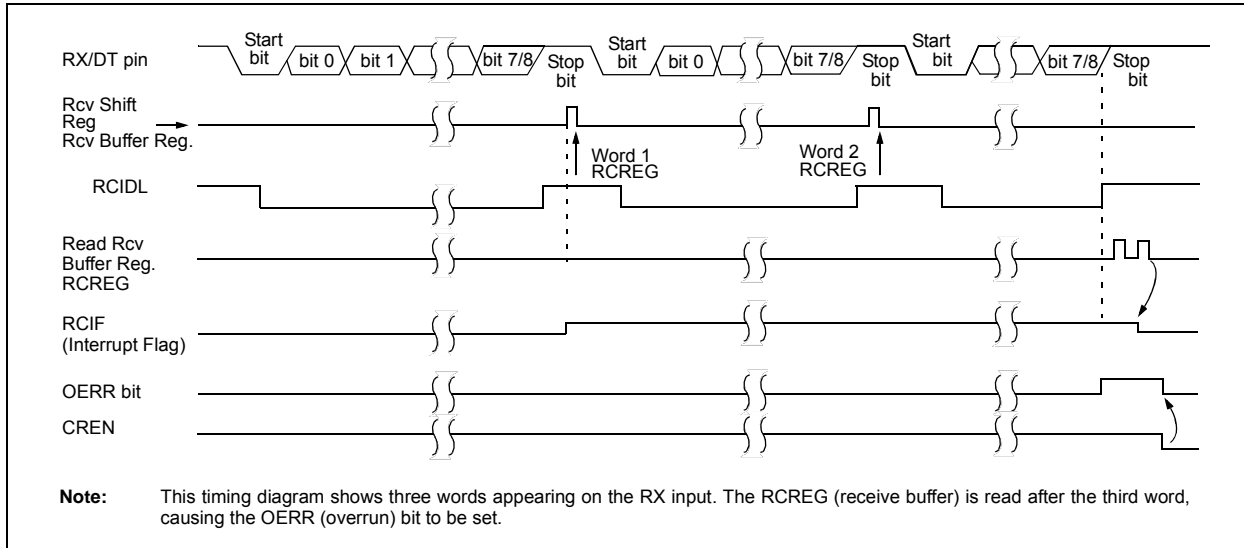

TABLE 21-2: SUMMARY OF REGISTERS ASSOCIATED WITH ASYNCHRONOUS RECEPTION

Name	Bit 7	Bit 6	Bit 5	Bit 4	Bit 3	Bit 2	Bit 1	Bit 0	Register on Page
BAUDCON	ABDOVF	RCIDL	—	SCKP	BRG16	—	WUE	ABDEN	245
INTCON	GIE	PEIE	TMR0IE	INTE	IOCIE	TMR0IF	INTF	IOCIF	77
PIE1	TMR1GIE	AD1IE	RCIE	TXIE	SSP1IE	—	TMR2IE	TMR1IE	78
PIR1	TMR1GIF	AD1IF	RCIF	TXIF	SSP1IF	—	TMR2IF	TMR1IF	80
RCREG	EUSART Receive Data Register								239*
RCSTA	SPEN	RX9	SREN	CREN	ADDEN	FERR	OERR	RX9D	244
SPBRGL	BRG<7:0>								246*
SPBRGH	BRG<15:8>								246*
TRISB	TRISB7	TRISB6	TRISB5	TRISB4	—	—	—	—	112
TXSTA	CSRC	TX9	TXEN	SYNC	SENDB	BRGH	TRMT	TX9D	243

Legend: — = unimplemented location, read as '0'. Shaded cells are not used for asynchronous reception.

* Page provides register information.

21.2 Clock Accuracy with Asynchronous Operation

The factory calibrates the internal oscillator block output (INTOSC). However, the INTOSC frequency may drift as VDD or temperature changes, and this directly affects the asynchronous baud rate.

The Auto-Baud Detect feature (see [Section 21.4.1 "Auto-Baud Detect"](#)) can be used to compensate for changes in the INTOSC frequency.

There may not be fine enough resolution when adjusting the Baud Rate Generator to compensate for a gradual change in the peripheral clock frequency.

21.3 Register Definitions: EUSART Control

REGISTER 21-1: TXSTA: TRANSMIT STATUS AND CONTROL REGISTER

R/W-0	R/W-0/0	R/W-0/0	R/W-0/0	R/W-0/0	R/W-0/0	R-1/1	R/W-0/0
CSRC	TX9	TXEN ⁽¹⁾	SYNC	SENDB	BRGH	TRMT	TX9D
bit 7						bit 0	

Legend:

R = Readable bit

W = Writable bit

U = Unimplemented bit, read as '0'

u = Bit is unchanged

x = Bit is unknown

-n/n = Value at POR and BOR/Value at all other Resets

'1' = Bit is set

'0' = Bit is cleared

- bit 7 **CSRC:** Clock Source Select bit
Asynchronous mode:
 Don't care
Synchronous mode:
 1 = Master mode (clock generated internally from BRG)
 0 = Slave mode (clock from external source)
- bit 6 **TX9:** 9-bit Transmit Enable bit
 1 = Selects 9-bit transmission
 0 = Selects 8-bit transmission
- bit 5 **TXEN:** Transmit Enable bit⁽¹⁾
 1 = Transmit enabled
 0 = Transmit disabled
- bit 4 **SYNC:** EUSART Mode Select bit
 1 = Synchronous mode
 0 = Asynchronous mode
- bit 3 **SENDB:** Send Break Character bit
Asynchronous mode:
 1 = Send Sync Break on next transmission (cleared by hardware upon completion)
 0 = Sync Break transmission completed
Synchronous mode:
 Don't care
- bit 2 **BRGH:** High Baud Rate Select bit
Asynchronous mode:
 1 = High speed
 0 = Low speed
Synchronous mode:
 Unused in this mode
- bit 1 **TRMT:** Transmit Shift Register Status bit
 1 = TSR empty
 0 = TSR full
- bit 0 **TX9D:** Ninth bit of Transmit Data
 Can be address/data bit or a parity bit.

Note 1: SREN/CREN overrides TXEN in Sync mode.

PIC16LF1554/1559

REGISTER 21-2: RCSTA: RECEIVE STATUS AND CONTROL REGISTER

R/W-0/0	R/W-0/0	R/W-0/0	R/W-0/0	R/W-0/0	R-0/0	R-0/0	R-0/0
SPEN	RX9	SREN	CREN	ADDEN	FERR	OERR	RX9D
bit 7						bit 0	

Legend:

R = Readable bit	W = Writable bit	U = Unimplemented bit, read as '0'
u = Bit is unchanged	x = Bit is unknown	-n/n = Value at POR and BOR/Value at all other Resets
'1' = Bit is set	'0' = Bit is cleared	

- bit 7 **SPEN:** Serial Port Enable bit
 1 = Serial port enabled (configures RX/DT and TX/CK pins as serial port pins)
 0 = Serial port disabled (held in Reset)
- bit 6 **RX9:** 9-bit Receive Enable bit
 1 = Selects 9-bit reception
 0 = Selects 8-bit reception
- bit 5 **SREN:** Single Receive Enable bit
Asynchronous mode:
 Don't care
Synchronous mode – Master:
 1 = Enables single receive
 0 = Disables single receive
 This bit is cleared after reception is complete.
Synchronous mode – Slave
 Don't care
- bit 4 **CREN:** Continuous Receive Enable bit
Asynchronous mode:
 1 = Enables receiver
 0 = Disables receiver
Synchronous mode:
 1 = Enables continuous receive until enable bit CREN is cleared (CREN overrides SREN)
 0 = Disables continuous receive
- bit 3 **ADDEN:** Address Detect Enable bit
Asynchronous mode 9-bit (RX9 = 1):
 1 = Enables address detection, enable interrupt and load the receive buffer when RSR<8> is set
 0 = Disables address detection, all bytes are received and ninth bit can be used as parity bit
Asynchronous mode 8-bit (RX9 = 0):
 Don't care
- bit 2 **FERR:** Framing Error bit
 1 = Framing error (can be updated by reading RCREG register and receive next valid byte)
 0 = No framing error
- bit 1 **OERR:** Overrun Error bit
 1 = Overrun error (can be cleared by clearing bit CREN)
 0 = No overrun error
- bit 0 **RX9D:** Ninth bit of Received Data
 This can be address/data bit or a parity bit and must be calculated by user firmware.

REGISTER 21-3: BAUDCON: BAUD RATE CONTROL REGISTER

R-0/0	R-1/1	U-0	R/W-0/0	R/W-0/0	U-0	R/W-0/0	R/W-0/0
ABDOVF	RCIDL	—	SCKP	BRG16	—	WUE	ABDEN
bit 7							bit 0

Legend:

R = Readable bit	W = Writable bit	U = Unimplemented bit, read as '0'
u = Bit is unchanged	x = Bit is unknown	-n/n = Value at POR and BOR/Value at all other Resets
'1' = Bit is set	'0' = Bit is cleared	

bit 7 **ABDOVF:** Auto-Baud Detect Overflow bit

Asynchronous mode:

- 1 = Auto-baud timer overflowed
- 0 = Auto-baud timer did not overflow

Synchronous mode:

Don't care

bit 6 **RCIDL:** Receive Idle Flag bit

Asynchronous mode:

- 1 = Receiver is idle
- 0 = Start bit has been received and the receiver is receiving

Synchronous mode:

Don't care

bit 5 **Unimplemented:** Read as '0'

bit 4 **SCKP:** Synchronous Clock Polarity Select bit

Asynchronous mode:

- 1 = Transmit inverted data to the TX/CK pin
- 0 = Transmit non-inverted data to the TX/CK pin

Synchronous mode:

- 1 = Data is clocked on rising edge of the clock
- 0 = Data is clocked on falling edge of the clock

bit 3 **BRG16:** 16-bit Baud Rate Generator bit

- 1 = 16-bit Baud Rate Generator is used
- 0 = 8-bit Baud Rate Generator is used

bit 2 **Unimplemented:** Read as '0'

bit 1 **WUE:** Wake-up Enable bit

Asynchronous mode:

- 1 = Receiver is waiting for a falling edge. No character will be received, RCIF bit will be set. WUE will automatically clear after RCIF is set.
- 0 = Receiver is operating normally

Synchronous mode:

Don't care

bit 0 **ABDEN:** Auto-Baud Detect Enable bit

Asynchronous mode:

- 1 = Auto-Baud Detect mode is enabled (clears when auto-baud is complete)
- 0 = Auto-Baud Detect mode is disabled

Synchronous mode:

Don't care

PIC16LF1554/1559

21.4 EUSART Baud Rate Generator (BRG)

The Baud Rate Generator (BRG) is an 8-bit or 16-bit timer that is dedicated to the support of both the asynchronous and synchronous EUSART operation. By default, the BRG operates in 8-bit mode. Setting the BRG16 bit of the BAUDCON register selects 16-bit mode.

The SPBRGH, SPBRGL register pair determines the period of the free running baud rate timer. In Asynchronous mode the multiplier of the baud rate period is determined by both the BRGH bit of the TXSTA register and the BRG16 bit of the BAUDCON register. In Synchronous mode, the BRGH bit is ignored.

Table 21-3 contains the formulas for determining the baud rate. Example 21-1 provides a sample calculation for determining the baud rate and baud rate error.

Typical baud rates and error values for various asynchronous modes have been computed for your convenience and are shown in Table 21-3. It may be advantageous to use the high baud rate (BRGH = 1), or the 16-bit BRG (BRG16 = 1) to reduce the baud rate error. The 16-bit BRG mode is used to achieve slow baud rates for fast oscillator frequencies.

Writing a new value to the SPBRGH, SPBRGL register pair causes the BRG timer to be reset (or cleared). This ensures that the BRG does not wait for a timer overflow before outputting the new baud rate.

If the system clock is changed during an active receive operation, a receive error or data loss may result. To avoid this problem, check the status of the RCIDL bit to make sure that the receive operation is idle before changing the system clock.

EXAMPLE 21-1: CALCULATING BAUD RATE ERROR

For a device with Fosc of 16 MHz, desired baud rate of 9600, Asynchronous mode, 8-bit BRG:

$$\text{Desired Baud Rate} = \frac{F_{osc}}{64(SPBRGH:SPBRGL + 1)}$$

Solving for SPBRGH:SPBRGL:

$$X = \frac{F_{osc}}{\text{Desired Baud Rate} \cdot 64} - 1$$

$$= \frac{16000000}{9600 \cdot 64} - 1$$

$$= [25.042] = 25$$

$$\text{Calculated Baud Rate} = \frac{16000000}{64(25 + 1)}$$

$$= 9615$$

$$\text{Error} = \frac{\text{Calc. Baud Rate} - \text{Desired Baud Rate}}{\text{Desired Baud Rate}}$$

$$= \frac{(9615 - 9600)}{9600} = 0.16\%$$

TABLE 21-3: BAUD RATE FORMULAS

Configuration Bits			BRG/EUSART Mode	Baud Rate Formula
SYNC	BRG16	BRGH		
0	0	0	8-bit/Asynchronous	$F_{osc}/[64 (n+1)]$
0	0	1	8-bit/Asynchronous	$F_{osc}/[16 (n+1)]$
0	1	0	16-bit/Asynchronous	
0	1	1	16-bit/Asynchronous	$F_{osc}/[4 (n+1)]$
1	0	x	8-bit/Synchronous	
1	1	x	16-bit/Synchronous	

Legend: x = Don't care, n = value of SPBRGH, SPBRGL register pair.

TABLE 21-4: SUMMARY OF REGISTERS ASSOCIATED WITH THE BAUD RATE GENERATOR

Name	Bit 7	Bit 6	Bit 5	Bit 4	Bit 3	Bit 2	Bit 1	Bit 0	Register on Page
BAUDCON	ABDOVF	RCIDL	—	SCKP	BRG16	—	WUE	ABDEN	245
RCSTA	SPEN	RX9	SREN	CREN	ADDEN	FERR	OERR	RX9D	244
SPBRGL	BRG<7:0>								246*
SPBRGH	BRG<15:8>								246*
TXSTA	CSRC	TX9	TXEN	SYNC	SENDB	BRGH	TRMT	TX9D	243

Legend: — = unimplemented location, read as '0'. Shaded cells are not used for the Baud Rate Generator.

* Page provides register information.

PIC16LF1554/1559

TABLE 21-5: BAUD RATES FOR ASYNCHRONOUS MODES

BAUD RATE	SYNC = 0, BRGH = 0, BRG16 = 0											
	Fosc = 32.000 MHz			Fosc = 20.000 MHz			Fosc = 18.432 MHz			Fosc = 11.0592 MHz		
	Actual Rate	% Error	SPBRG value (decimal)	Actual Rate	% Error	SPBRG value (decimal)	Actual Rate	% Error	SPBRG value (decimal)	Actual Rate	% Error	SPBRG value (decimal)
300	—	—	—	—	—	—	—	—	—	—	—	—
1200	—	—	—	1221	1.73	255	1200	0.00	239	1200	0.00	143
2400	2404	0.16	207	2404	0.16	129	2400	0.00	119	2400	0.00	71
9600	9615	0.16	51	9470	-1.36	32	9600	0.00	29	9600	0.00	17
10417	10417	0.00	47	10417	0.00	29	10286	-1.26	27	10165	-2.42	16
19.2k	19.23k	0.16	25	19.53k	1.73	15	19.20k	0.00	14	19.20k	0.00	8
57.6k	55.55k	-3.55	3	—	—	—	57.60k	0.00	7	57.60k	0.00	2
115.2k	—	—	—	—	—	—	—	—	—	—	—	—

BAUD RATE	SYNC = 0, BRGH = 0, BRG16 = 0											
	Fosc = 8.000 MHz			Fosc = 4.000 MHz			Fosc = 3.6864 MHz			Fosc = 1.000 MHz		
	Actual Rate	% Error	SPBRG value (decimal)	Actual Rate	% Error	SPBRG value (decimal)	Actual Rate	% Error	SPBRG value (decimal)	Actual Rate	% Error	SPBRG value (decimal)
300	—	—	—	300	0.16	207	300	0.00	191	300	0.16	51
1200	1202	0.16	103	1202	0.16	51	1200	0.00	47	1202	0.16	12
2400	2404	0.16	51	2404	0.16	25	2400	0.00	23	—	—	—
9600	9615	0.16	12	—	—	—	9600	0.00	5	—	—	—
10417	10417	0.00	11	10417	0.00	5	—	—	—	—	—	—
19.2k	—	—	—	—	—	—	19.20k	0.00	2	—	—	—
57.6k	—	—	—	—	—	—	57.60k	0.00	0	—	—	—
115.2k	—	—	—	—	—	—	—	—	—	—	—	—

BAUD RATE	SYNC = 0, BRGH = 1, BRG16 = 0											
	Fosc = 32.000 MHz			Fosc = 20.000 MHz			Fosc = 18.432 MHz			Fosc = 11.0592 MHz		
	Actual Rate	% Error	SPBRG value (decimal)	Actual Rate	% Error	SPBRG value (decimal)	Actual Rate	% Error	SPBRG value (decimal)	Actual Rate	% Error	SPBRG value (decimal)
300	—	—	—	—	—	—	—	—	—	—	—	—
1200	—	—	—	—	—	—	—	—	—	—	—	—
2400	—	—	—	—	—	—	—	—	—	—	—	—
9600	9615	0.16	207	9615	0.16	129	9600	0.00	119	9600	0.00	71
10417	10417	0.00	191	10417	0.00	119	10378	-0.37	110	10473	0.53	65
19.2k	19.23k	0.16	103	19.23k	0.16	64	19.20k	0.00	59	19.20k	0.00	35
57.6k	57.14k	-0.79	34	56.82k	-1.36	21	57.60k	0.00	19	57.60k	0.00	11
115.2k	117.64k	2.12	16	113.64k	-1.36	10	115.2k	0.00	9	115.2k	0.00	5

TABLE 21-5: BAUD RATES FOR ASYNCHRONOUS MODES (CONTINUED)

BAUD RATE	SYNC = 0, BRGH = 1, BRG16 = 0											
	Fosc = 8.000 MHz			Fosc = 4.000 MHz			Fosc = 3.6864 MHz			Fosc = 1.000 MHz		
	Actual Rate	% Error	SPBRG value (decimal)	Actual Rate	% Error	SPBRG value (decimal)	Actual Rate	% Error	SPBRG value (decimal)	Actual Rate	% Error	SPBRG value (decimal)
300	—	—	—	—	—	—	—	—	—	300	0.16	207
1200	—	—	—	1202	0.16	207	1200	0.00	191	1202	0.16	51
2400	2404	0.16	207	2404	0.16	103	2400	0.00	95	2404	0.16	25
9600	9615	0.16	51	9615	0.16	25	9600	0.00	23	—	—	—
10417	10417	0.00	47	10417	0.00	23	10473	0.53	21	10417	0.00	5
19.2k	19231	0.16	25	19.23k	0.16	12	19.2k	0.00	11	—	—	—
57.6k	55556	-3.55	8	—	—	—	57.60k	0.00	3	—	—	—
115.2k	—	—	—	—	—	—	115.2k	0.00	1	—	—	—

BAUD RATE	SYNC = 0, BRGH = 0, BRG16 = 1											
	Fosc = 32.000 MHz			Fosc = 20.000 MHz			Fosc = 18.432 MHz			Fosc = 11.0592 MHz		
	Actual Rate	% Error	SPBRG value (decimal)	Actual Rate	% Error	SPBRG value (decimal)	Actual Rate	% Error	SPBRG value (decimal)	Actual Rate	% Error	SPBRG value (decimal)
300	300.0	0.00	6666	300.0	-0.01	4166	300.0	0.00	3839	300.0	0.00	2303
1200	1200	-0.02	3332	1200	-0.03	1041	1200	0.00	959	1200	0.00	575
2400	2401	-0.04	832	2399	-0.03	520	2400	0.00	479	2400	0.00	287
9600	9615	0.16	207	9615	0.16	129	9600	0.00	119	9600	0.00	71
10417	10417	0.00	191	10417	0.00	119	10378	-0.37	110	10473	0.53	65
19.2k	19.23k	0.16	103	19.23k	0.16	64	19.20k	0.00	59	19.20k	0.00	35
57.6k	57.14k	-0.79	34	56.818	-1.36	21	57.60k	0.00	19	57.60k	0.00	11
115.2k	117.6k	2.12	16	113.636	-1.36	10	115.2k	0.00	9	115.2k	0.00	5

BAUD RATE	SYNC = 0, BRGH = 0, BRG16 = 1											
	Fosc = 8.000 MHz			Fosc = 4.000 MHz			Fosc = 3.6864 MHz			Fosc = 1.000 MHz		
	Actual Rate	% Error	SPBRG value (decimal)	Actual Rate	% Error	SPBRG value (decimal)	Actual Rate	% Error	SPBRG value (decimal)	Actual Rate	% Error	SPBRG value (decimal)
300	299.9	-0.02	1666	300.1	0.04	832	300.0	0.00	767	300.5	0.16	207
1200	1199	-0.08	416	1202	0.16	207	1200	0.00	191	1202	0.16	51
2400	2404	0.16	207	2404	0.16	103	2400	0.00	95	2404	0.16	25
9600	9615	0.16	51	9615	0.16	25	9600	0.00	23	—	—	—
10417	10417	0.00	47	10417	0.00	23	10473	0.53	21	10417	0.00	5
19.2k	19.23k	0.16	25	19.23k	0.16	12	19.20k	0.00	11	—	—	—
57.6k	55556	-3.55	8	—	—	—	57.60k	0.00	3	—	—	—
115.2k	—	—	—	—	—	—	115.2k	0.00	1	—	—	—

PIC16LF1554/1559

TABLE 21-5: BAUD RATES FOR ASYNCHRONOUS MODES (CONTINUED)

BAUD RATE	SYNC = 0, BRGH = 1, BRG16 = 1 or SYNC = 1, BRG16 = 1											
	Fosc = 32.000 MHz			Fosc = 20.000 MHz			Fosc = 18.432 MHz			Fosc = 11.0592 MHz		
	Actual Rate	% Error	SPBRG value (decimal)	Actual Rate	% Error	SPBRG value (decimal)	Actual Rate	% Error	SPBRG value (decimal)	Actual Rate	% Error	SPBRG value (decimal)
300	300.0	0.00	26666	300.0	0.00	16665	300.0	0.00	15359	300.0	0.00	9215
1200	1200	0.00	6666	1200	-0.01	4166	1200	0.00	3839	1200	0.00	2303
2400	2400	0.01	3332	2400	0.02	2082	2400	0.00	1919	2400	0.00	1151
9600	9604	0.04	832	9597	-0.03	520	9600	0.00	479	9600	0.00	287
10417	10417	0.00	767	10417	0.00	479	10425	0.08	441	10433	0.16	264
19.2k	19.18k	-0.08	416	19.23k	0.16	259	19.20k	0.00	239	19.20k	0.00	143
57.6k	57.55k	-0.08	138	57.47k	-0.22	86	57.60k	0.00	79	57.60k	0.00	47
115.2k	115.9k	0.64	68	116.3k	0.94	42	115.2k	0.00	39	115.2k	0.00	23

BAUD RATE	SYNC = 0, BRGH = 1, BRG16 = 1 or SYNC = 1, BRG16 = 1											
	Fosc = 8.000 MHz			Fosc = 4.000 MHz			Fosc = 3.6864 MHz			Fosc = 1.000 MHz		
	Actual Rate	% Error	SPBRG value (decimal)	Actual Rate	% Error	SPBRG value (decimal)	Actual Rate	% Error	SPBRG value (decimal)	Actual Rate	% Error	SPBRG value (decimal)
300	300.0	0.00	6666	300.0	0.01	3332	300.0	0.00	3071	300.1	0.04	832
1200	1200	-0.02	1666	1200	0.04	832	1200	0.00	767	1202	0.16	207
2400	2401	0.04	832	2398	0.08	416	2400	0.00	383	2404	0.16	103
9600	9615	0.16	207	9615	0.16	103	9600	0.00	95	9615	0.16	25
10417	10417	0	191	10417	0.00	95	10473	0.53	87	10417	0.00	23
19.2k	19.23k	0.16	103	19.23k	0.16	51	19.20k	0.00	47	19.23k	0.16	12
57.6k	57.14k	-0.79	34	58.82k	2.12	16	57.60k	0.00	15	—	—	—
115.2k	117.6k	2.12	16	111.1k	-3.55	8	115.2k	0.00	7	—	—	—

21.4.1 AUTO-BAUD DETECT

The EUSART module supports automatic detection and calibration of the baud rate.

In the Auto-Baud Detect (ABD) mode, the clock to the BRG is reversed. Rather than the BRG clocking the incoming RX signal, the RX signal is timing the BRG. The Baud Rate Generator is used to time the period of a received 55h (ASCII “U”) which is the Sync character for the LIN bus. The unique feature of this character is that it has five rising edges including the Stop bit edge.

Setting the ABDEN bit of the BAUDCON register starts the auto-baud calibration sequence (Figure 21-6). While the ABD sequence takes place, the EUSART state machine is held in Idle. On the first rising edge of the receive line, after the Start bit, the SPBRG begins counting up using the BRG counter clock as shown in Table 21-6. The fifth rising edge will occur on the RX pin at the end of the eighth bit period. At that time, an accumulated value totaling the proper BRG period is left in the SPBRGH, SPBRGL register pair, the ABDEN bit is automatically cleared and the RCIF interrupt flag is set. The value in the RCREG needs to be read to clear the RCIF interrupt. RCREG content should be discarded. When calibrating for modes that do not use the SPBRGH register the user can verify that the SPBRGL register did not overflow by checking for 00h in the SPBRGH register.

The BRG auto-baud clock is determined by the BRG16 and BRGH bits as shown in Table 21-6. During ABD, both the SPBRGH and SPBRGL registers are used as a 16-bit counter, independent of the BRG16 bit setting. While calibrating the baud rate period, the SPBRGH and SPBRGL registers are clocked at 1/8th the BRG base clock rate. The resulting byte measurement is the average bit time when clocked at full speed.

Note 1: If the WUE bit is set with the ABDEN bit, auto-baud detection will occur on the byte following the Break character (see Section 21.4.3 “Auto-Wake-up on Break”).

2: It is up to the user to determine that the incoming character baud rate is within the range of the selected BRG clock source. Some combinations of oscillator frequency and EUSART baud rates are not possible.

3: During the auto-baud process, the auto-baud counter starts counting at 1. Upon completion of the auto-baud sequence, to achieve maximum accuracy, subtract 1 from the SPBRGH:SPBRGL register pair.

TABLE 21-6: BRG COUNTER CLOCK RATES⁽¹⁾

BRG16	BRGH	BRG Base Clock	BRG ABD Clock
0	0	Fosc/64	Fosc/512
0	1	Fosc/16	Fosc/128
1	0	Fosc/16	Fosc/128
1	1	Fosc/4	Fosc/32

Note 1: During the ABD sequence, SPBRGL and SPBRGH registers are both used as a 16-bit counter, independent of BRG16 setting.

FIGURE 21-6: AUTOMATIC BAUD RATE CALIBRATION

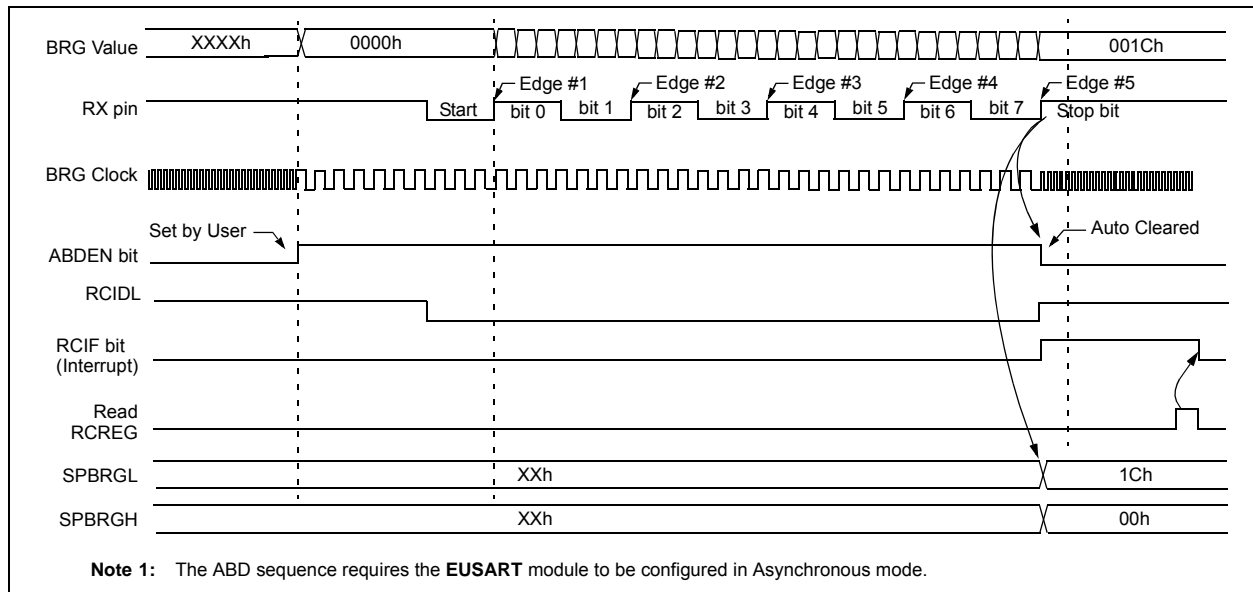

PIC16LF1554/1559

21.4.2 AUTO-BAUD OVERFLOW

During the course of automatic baud detection, the ABDOVF bit of the BAUDCON register will be set if the baud rate counter overflows before the fifth rising edge is detected on the RX pin. The ABDOVF bit indicates that the counter has exceeded the maximum count that can fit in the 16 bits of the SPBRGH:SPBRGL register pair. After the ABDOVF bit has been set, the counter continues to count until the fifth rising edge is detected on the RX pin. Upon detecting the fifth RX edge, the hardware will set the RCIF interrupt flag and clear the ABDEN bit of the BAUDCON register. The RCIF flag can be subsequently cleared by reading the RCREG register. The ABDOVF flag of the BAUDCON register can be cleared by software directly.

To terminate the auto-baud process before the RCIF flag is set, clear the ABDEN bit then clear the ABDOVF bit of the BAUDCON register. The ABDOVF bit will remain set if the ABDEN bit is not cleared first.

21.4.3 AUTO-WAKE-UP ON BREAK

During Sleep mode, all clocks to the EUSART are suspended. Because of this, the Baud Rate Generator is inactive and a proper character reception cannot be performed. The Auto-Wake-up feature allows the controller to wake-up due to activity on the RX/DT line. This feature is available only in Asynchronous mode.

The Auto-Wake-up feature is enabled by setting the WUE bit of the BAUDCON register. Once set, the normal receive sequence on RX/DT is disabled, and the EUSART remains in an Idle state, monitoring for a wake-up event independent of the CPU mode. A wake-up event consists of a high-to-low transition on the RX/DT line. This coincides with the start of a Sync Break or a wake-up signal character for the LIN protocol.

The EUSART module generates an RCIF interrupt coincident with the wake-up event. The interrupt is generated synchronously to the Q clocks in normal CPU operating modes (Figure 21-7), and asynchronously if the device is in Sleep mode (Figure 21-8). The interrupt condition is cleared by reading the RCREG register.

The WUE bit is automatically cleared by the low-to-high transition on the RX line at the end of the Break. This signals to the user that the Break event is over. At this point, the EUSART module is in Idle mode waiting to receive the next character.

21.4.3.1 Special Considerations

Break Character

To avoid character errors or character fragments during a wake-up event, the wake-up character must be all zeros.

When the wake-up is enabled the function works independent of the low time on the data stream. If the WUE bit is set and a valid non-zero character is received, the low time from the Start bit to the first rising edge will be interpreted as the wake-up event. The remaining bits in the character will be received as a fragmented character and subsequent characters can result in framing or overrun errors.

Therefore, the initial character in the transmission must be all '0's. This must be ten or more bit times, 13-bit times recommended for LIN bus, or any number of bit times for standard RS-232 devices.

Oscillator Start-up Time

Oscillator start-up time must be considered, especially in applications using oscillators with longer start-up intervals (i.e., LP, XT or HS/PLL mode). The Sync Break (or wake-up signal) character must be of sufficient length, and be followed by a sufficient interval, to allow enough time for the selected oscillator to start and provide proper initialization of the EUSART.

WUE Bit

The wake-up event causes a receive interrupt by setting the RCIF bit. The WUE bit is cleared in hardware by a rising edge on RX/DT. The interrupt condition is then cleared in software by reading the RCREG register and discarding its contents.

To ensure that no actual data is lost, check the RCIDL bit to verify that a receive operation is not in process before setting the WUE bit. If a receive operation is not occurring, the WUE bit may then be set just prior to entering the Sleep mode.

FIGURE 21-7: AUTO-WAKE-UP BIT (WUE) TIMING DURING NORMAL OPERATION

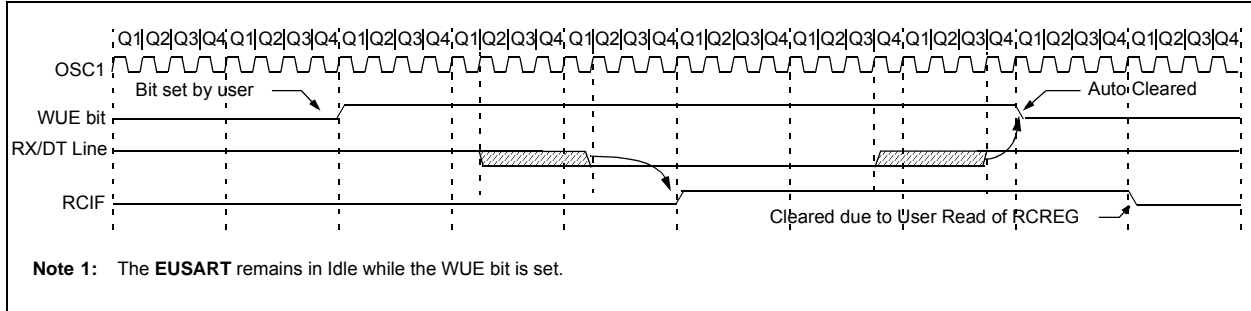
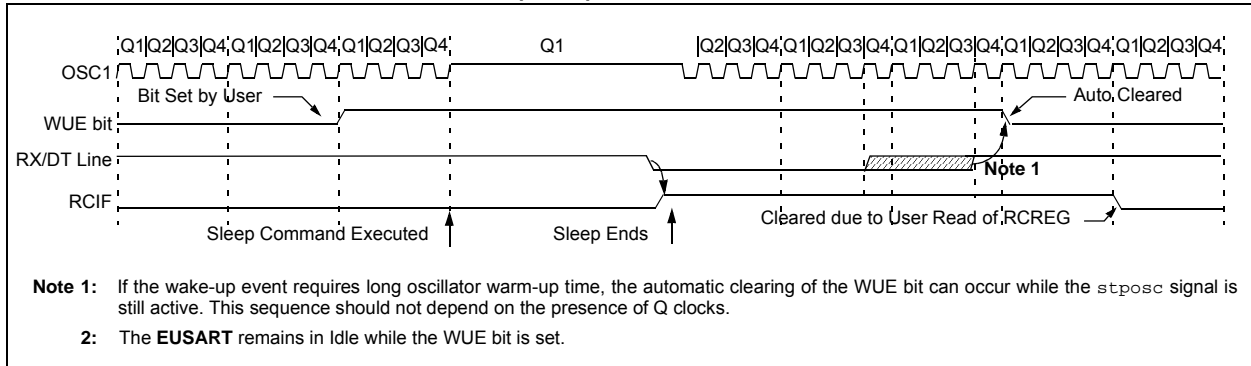

FIGURE 21-8: AUTO-WAKE-UP BIT (WUE) TIMINGS DURING SLEEP



PIC16LF1554/1559

21.4.4 BREAK CHARACTER SEQUENCE

The EUSART module has the capability of sending the special Break character sequences that are required by the LIN bus standard. A Break character consists of a Start bit, followed by 12 '0' bits and a Stop bit.

To send a Break character, set the SENDB and TXEN bits of the TXSTA register. The Break character transmission is then initiated by a write to the TXREG. The value of data written to TXREG will be ignored and all '0's will be transmitted.

The SENDB bit is automatically reset by hardware after the corresponding Stop bit is sent. This allows the user to preload the transmit FIFO with the next transmit byte following the Break character (typically, the Sync character in the LIN specification).

The TRMT bit of the TXSTA register indicates when the transmit operation is active or idle, just as it does during normal transmission. See [Figure 21-9](#) for the timing of the Break character sequence.

21.4.4.1 Break and Sync Transmit Sequence

The following sequence will start a message frame header made up of a Break, followed by an auto-baud Sync byte. This sequence is typical of a LIN bus master.

1. Configure the EUSART for the desired mode.
2. Set the TXEN and SENDB bits to enable the Break sequence.
3. Load the TXREG with a dummy character to initiate transmission (the value is ignored).
4. Write '55h' to TXREG to load the Sync character into the transmit FIFO buffer.
5. After the Break has been sent, the SENDB bit is reset by hardware and the Sync character is then transmitted.

When the TXREG becomes empty, as indicated by the TXIF, the next data byte can be written to TXREG.

21.4.5 RECEIVING A BREAK CHARACTER

The Enhanced EUSART module can receive a Break character in two ways.

The first method to detect a Break character uses the FERR bit of the RCSTA register and the received data as indicated by RCREG. The Baud Rate Generator is assumed to have been initialized to the expected baud rate.

A Break character has been received when;

- RCIF bit is set
- FERR bit is set
- RCREG = 00h

The second method uses the Auto-Wake-up feature described in [Section 21.4.3 "Auto-Wake-up on Break"](#). By enabling this feature, the EUSART will sample the next two transitions on RX/DT, cause an RCIF interrupt, and receive the next data byte followed by another interrupt.

Note that following a Break character, the user will typically want to enable the Auto-Baud Detect feature. For both methods, the user can set the ABDEN bit of the BAUDCON register before placing the EUSART in Sleep mode.

FIGURE 21-9: SEND BREAK CHARACTER SEQUENCE

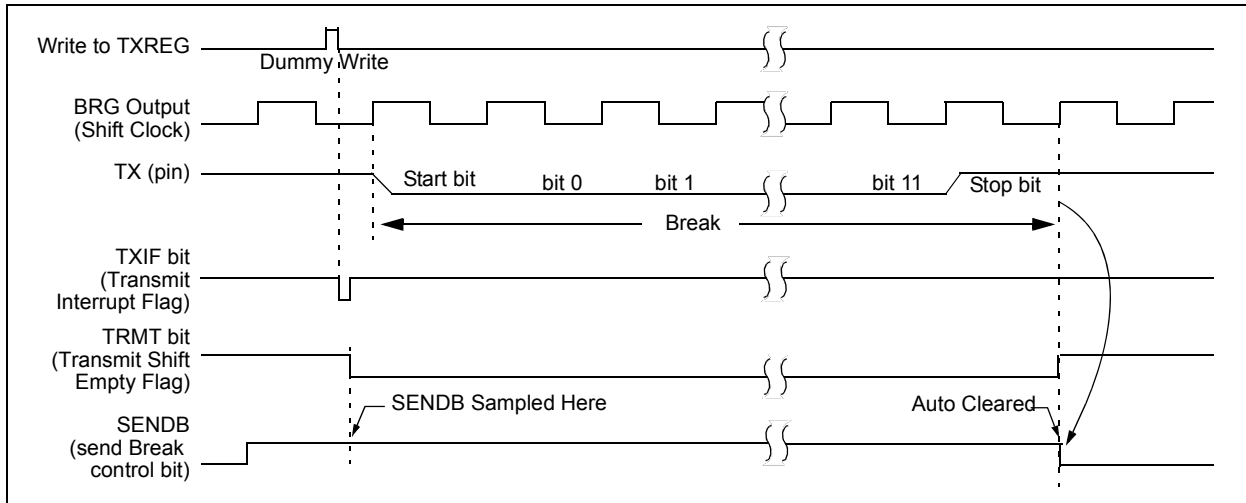

21.5 EUSART Synchronous Mode

Synchronous serial communications are typically used in systems with a single master and one or more slaves. The master device contains the necessary circuitry for baud rate generation and supplies the clock for all devices in the system. Slave devices can take advantage of the master clock by eliminating the internal clock generation circuitry.

There are two signal lines in Synchronous mode: a bidirectional data line and a clock line. Slaves use the external clock supplied by the master to shift the serial data into and out of their respective receive and transmit shift registers. Since the data line is bidirectional, synchronous operation is half-duplex only. Half-duplex refers to the fact that master and slave devices can receive and transmit data but not both simultaneously. The EUSART can operate as either a master or slave device.

Start and Stop bits are not used in synchronous transmissions.

21.5.1 SYNCHRONOUS MASTER MODE

The following bits are used to configure the EUSART for synchronous master operation:

- SYNC = 1
- CSRC = 1
- SREN = 0 (for transmit); SREN = 1 (for receive)
- CREN = 0 (for transmit); CREN = 1 (for receive)
- SPEN = 1

Setting the SYNC bit of the TXSTA register configures the device for synchronous operation. Setting the CSRC bit of the TXSTA register configures the device as a master. Clearing the SREN and CREN bits of the RCSTA register ensures that the device is in the Transmit mode, otherwise the device will be configured to receive. Setting the SPEN bit of the RCSTA register enables the EUSART.

21.5.1.1 Master Clock

Synchronous data transfers use a separate clock line, which is synchronous with the data. A device configured as a master transmits the clock on the TX/CK line. The TX/CK pin output driver is automatically enabled when the EUSART is configured for synchronous transmit or receive operation. Serial data bits change on the leading edge to ensure they are valid at the trailing edge of each clock. One clock cycle is generated for each data bit. Only as many clock cycles are generated as there are data bits.

21.5.1.2 Clock Polarity

A clock polarity option is provided for Microwire compatibility. Clock polarity is selected with the SCKP bit of the BAUDCON register. Setting the SCKP bit sets the clock Idle state as high. When the SCKP bit is set, the data changes on the falling edge of each clock. Clearing the SCKP bit sets the Idle state as low. When the SCKP bit is cleared, the data changes on the rising edge of each clock.

21.5.1.3 Synchronous Master Transmission

Data is transferred out of the device on the RX/DT pin. The RX/DT and TX/CK pin output drivers are automatically enabled when the EUSART is configured for synchronous master transmit operation.

A transmission is initiated by writing a character to the TXREG register. If the TSR still contains all or part of a previous character the new character data is held in the TXREG until the last bit of the previous character has been transmitted. If this is the first character, or the previous character has been completely flushed from the TSR, the data in the TXREG is immediately transferred to the TSR. The transmission of the character commences immediately following the transfer of the data to the TSR from the TXREG.

Each data bit changes on the leading edge of the master clock and remains valid until the subsequent leading clock edge.

Note: The TSR register is not mapped in data memory, so it is not available to the user.

21.5.1.4 Synchronous Master Transmission Set-up:

1. Initialize the SPBRGH, SPBRGL register pair and the BRGH and BRG16 bits to achieve the desired baud rate (see [Section 21.4 “EUSART Baud Rate Generator \(BRG\)”](#)).
2. Enable the synchronous master serial port by setting bits SYNC, SPEN and CSRC.
3. Disable Receive mode by clearing bits SREN and CREN.
4. Enable Transmit mode by setting the TXEN bit.
5. If 9-bit transmission is desired, set the TX9 bit.
6. If interrupts are desired, set the TXIE bit of the PIE1 register and the GIE and PEIE bits of the INTCON register.
7. If 9-bit transmission is selected, the ninth bit should be loaded in the TX9D bit.
8. Start transmission by loading data to the TXREG register.

PIC16LF1554/1559

FIGURE 21-10: SYNCHRONOUS TRANSMISSION

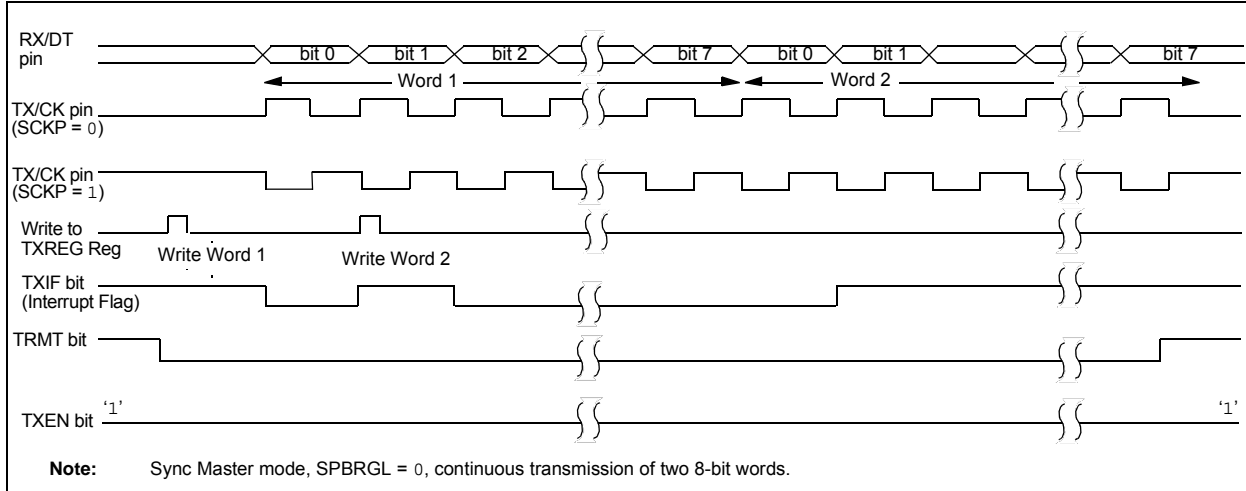

FIGURE 21-11: SYNCHRONOUS TRANSMISSION (THROUGH TXEN)

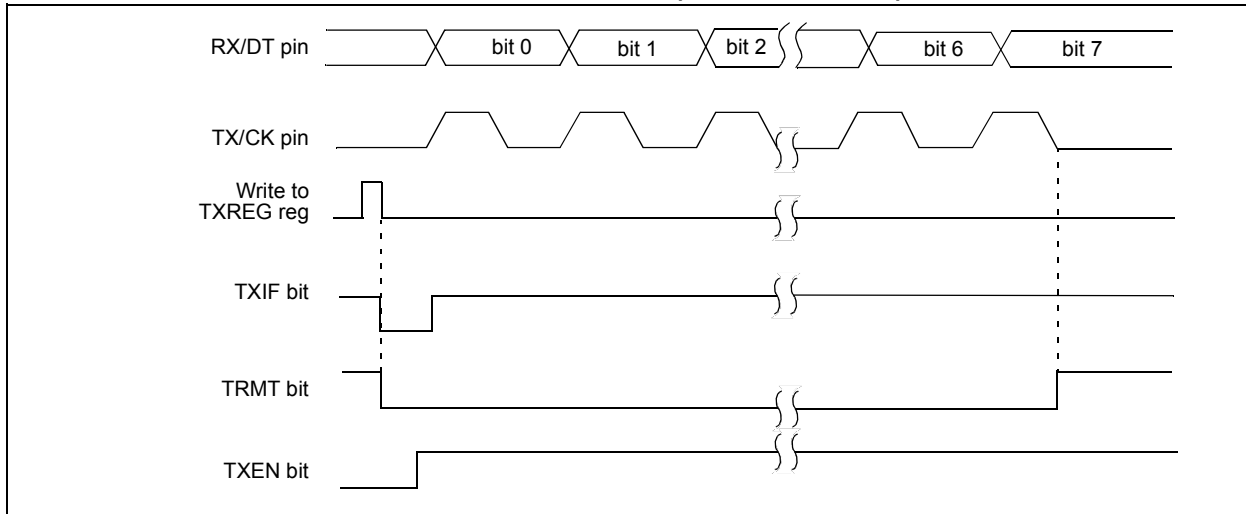

TABLE 21-7: SUMMARY OF REGISTERS ASSOCIATED WITH SYNCHRONOUS MASTER TRANSMISSION

Name	Bit 7	Bit 6	Bit 5	Bit 4	Bit 3	Bit 2	Bit 1	Bit 0	Register on Page
BAUDCON	ABDOVF	RCIDL	—	SCKP	BRG16	—	WUE	ABDEN	245
INTCON	GIE	PEIE	TMR0IE	INTE	IOCF	TMR0IF	INTF	IOCF	77
PIE1	TMR1GIE	AD1IE	RCIE	TXIE	SSP1IE	—	TMR2IE	TMR1IE	78
PIR1	TMR1GIF	AD1IF	RCIF	TXIF	SSP1IF	—	TMR2IF	TMR1IF	80
RCSTA	SPEN	RX9	SREN	CREN	ADDEN	FERR	OERR	RX9D	244
SPBRGL	BRG<7:0>								246*
SPBRGH	BRG<15:8>								246*
TRISB	TRISB7	TRISB6	TRISB5	TRISB4	—	—	—	—	112
TXREG	EUSART Transmit Data Register								236*
TXSTA	CSRC	TX9	TXEN	SYNC	SENDB	BRGH	TRMT	TX9D	243

Legend: — = unimplemented location, read as '0'. Shaded cells are not used for synchronous master transmission.

* Page provides register information.

21.5.1.5 Synchronous Master Reception

Data is received at the RX/DT pin. The RX/DT pin output driver is automatically disabled when the EUSART is configured for synchronous master receive operation.

In Synchronous mode, reception is enabled by setting either the Single Receive Enable bit (SREN of the RCSTA register) or the Continuous Receive Enable bit (CREN of the RCSTA register).

When SREN is set and CREN is clear, only as many clock cycles are generated as there are data bits in a single character. The SREN bit is automatically cleared at the completion of one character. When CREN is set, clocks are continuously generated until CREN is cleared. If CREN is cleared in the middle of a character the CK clock stops immediately and the partial character is discarded. If SREN and CREN are both set, then SREN is cleared at the completion of the first character and CREN takes precedence.

To initiate reception, set either SREN or CREN. Data is sampled at the RX/DT pin on the trailing edge of the TX/CK clock pin and is shifted into the Receive Shift Register (RSR). When a complete character is received into the RSR, the RCIF bit is set and the character is automatically transferred to the two character receive FIFO. The Least Significant eight bits of the top character in the receive FIFO are available in RCREG. The RCIF bit remains set as long as there are unread characters in the receive FIFO.

Note: If the RX/DT function is on an analog pin, the corresponding ANSELx bit must be cleared for the receiver to function.

21.5.1.6 Slave Clock

Synchronous data transfers use a separate clock line, which is synchronous with the data. A device configured as a slave receives the clock on the TX/CK line. The TX/CK pin output driver is automatically disabled when the device is configured for synchronous slave transmit or receive operation. Serial data bits change on the leading edge to ensure they are valid at the trailing edge of each clock. One data bit is transferred for each clock cycle. Only as many clock cycles should be received as there are data bits.

Note: If the device is configured as a slave and the TX/CK function is on an analog pin, the corresponding ANSELx bit must be cleared.

21.5.1.7 Receive Overrun Error

The receive FIFO buffer can hold two characters. An overrun error will be generated if a third character, in its entirety, is received before RCREG is read to access the FIFO. When this happens the OERR bit of the RCSTA register is set. Previous data in the FIFO will not be overwritten. The two characters in the FIFO

buffer can be read, however, no additional characters will be received until the error is cleared. The OERR bit can only be cleared by clearing the overrun condition. If the overrun error occurred when the SREN bit is set and CREN is clear then the error is cleared by reading RCREG. If the overrun occurred when the CREN bit is set then the error condition is cleared by either clearing the CREN bit of the RCSTA register or by clearing the SPEN bit which resets the EUSART.

21.5.1.8 Receiving 9-Bit Characters

The EUSART supports 9-bit character reception. When the RX9 bit of the RCSTA register is set, the EUSART will shift 9 bits into the RSR for each character received. The RX9D bit of the RCSTA register is the ninth, and Most Significant, data bit of the top unread character in the receive FIFO. When reading 9-bit data from the receive FIFO buffer, the RX9D data bit must be read before reading the eight Least Significant bits from the RCREG.

21.5.1.9 Synchronous Master Reception Set-up:

1. Initialize the SPBRGH, SPBRGL register pair for the appropriate baud rate. Set or clear the BRGH and BRG16 bits, as required, to achieve the desired baud rate.
2. Clear the ANSELx bit for the RX pin (if applicable).
3. Enable the synchronous master serial port by setting bits SYNC, SPEN and CSRC.
4. Ensure bits CREN and SREN are clear.
5. If interrupts are desired, set the RCIE bit of the PIE1 register and the GIE and PEIE bits of the INTCON register.
6. If 9-bit reception is desired, set bit RX9.
7. Start reception by setting the SREN bit or for continuous reception, set the CREN bit.
8. Interrupt flag bit RCIF will be set when reception of a character is complete. An interrupt will be generated if the enable bit RCIE was set.
9. Read the RCSTA register to get the ninth bit (if enabled) and determine if any error occurred during reception.
10. Read the 8-bit received data by reading the RCREG register.
11. If an overrun error occurs, clear the error by either clearing the CREN bit of the RCSTA register or by clearing the SPEN bit which resets the EUSART.

PIC16LF1554/1559

FIGURE 21-12: SYNCHRONOUS RECEPTION (MASTER MODE, SREN)

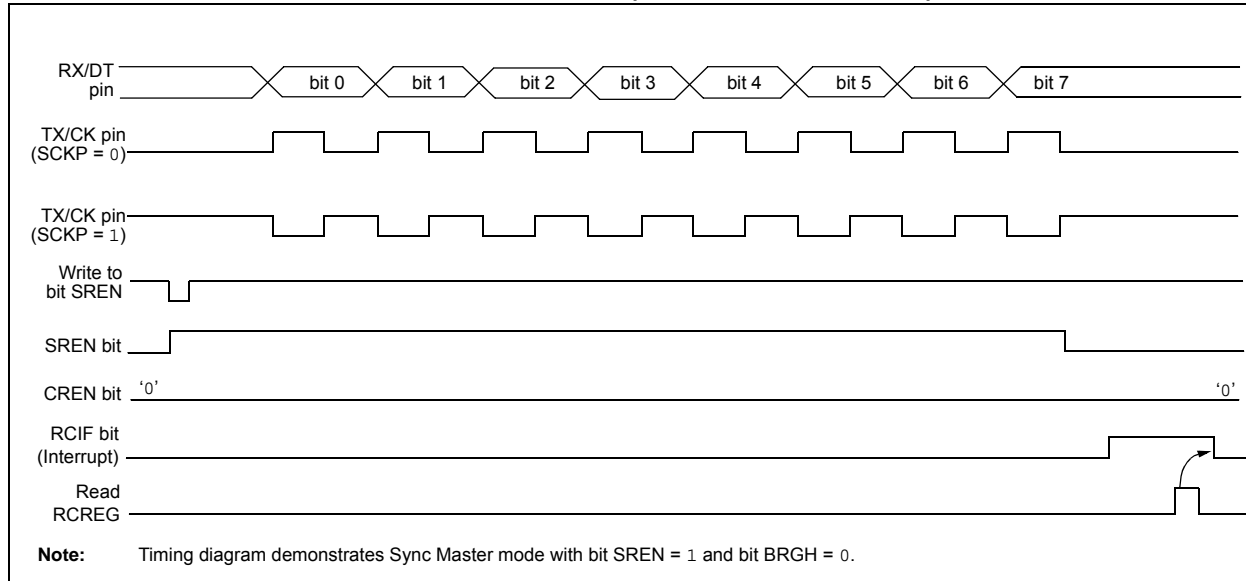

TABLE 21-8: SUMMARY OF REGISTERS ASSOCIATED WITH SYNCHRONOUS MASTER RECEPTION

Name	Bit 7	Bit 6	Bit 5	Bit 4	Bit 3	Bit 2	Bit 1	Bit 0	Register on Page
BAUDCON	ABDOVF	RCIDL	—	SCKP	BRG16	—	WUE	ABDEN	245
INTCON	GIE	PEIE	TMR0IE	INTE	IOCF	TMR0IF	INTF	IOCF	77
PIE1	TMR1GIE	AD1IE	RCIE	TXIE	SSP1IE	—	TMR2IE	TMR1IE	78
PIR1	TMR1GIF	AD1IF	RCIF	TXIF	SSP1IF	—	TMR2IF	TMR1IF	80
RCREG	EUSART Receive Data Register								239*
RCSTA	SPEN	RX9	SREN	CREN	ADDEN	FERR	OERR	RX9D	244
SPBRGL	BRG<7:0>								246*
SPBRGH	BRG<15:8>								246*
TRISB	TRISB7	TRISB6	TRISB5	TRISB4	—	—	—	—	112
TXSTA	CSRC	TX9	TXEN	SYNC	SENDER	BRGH	TRMT	TX9D	243

Legend: — = unimplemented location, read as '0'. Shaded cells are not used for synchronous master reception.

* Page provides register information.

21.5.2 SYNCHRONOUS SLAVE MODE

The following bits are used to configure the EUSART for synchronous slave operation:

- SYNC = 1
- CSRC = 0
- SREN = 0 (for transmit); SREN = 1 (for receive)
- CREN = 0 (for transmit); CREN = 1 (for receive)
- SPEN = 1

Setting the SYNC bit of the TXSTA register configures the device for synchronous operation. Clearing the CSRC bit of the TXSTA register configures the device as a slave. Clearing the SREN and CREN bits of the RCSTA register ensures that the device is in the Transmit mode, otherwise the device will be configured to receive. Setting the SPEN bit of the RCSTA register enables the EUSART.

21.5.2.1 EUSART Synchronous Slave Transmit

The operation of the Synchronous Master and Slave modes are identical (see [Section 21.5.1.3 “Synchronous Master Transmission”](#)), except in the case of the Sleep mode.

If two words are written to the TXREG and then the SLEEP instruction is executed, the following will occur:

1. The first character will immediately transfer to the TSR register and transmit.
2. The second word will remain in the TXREG register.
3. The TXIF bit will not be set.
4. After the first character has been shifted out of TSR, the TXREG register will transfer the second character to the TSR and the TXIF bit will now be set.
5. If the PEIE and TXIE bits are set, the interrupt will wake the device from Sleep and execute the next instruction. If the GIE bit is also set, the program will call the Interrupt Service Routine.

21.5.2.2 Synchronous Slave Transmission Set-up:

1. Set the SYNC and SPEN bits and clear the CSRC bit.
2. Clear the ANSELx bit for the CK pin (if applicable).
3. Clear the CREN and SREN bits.
4. If interrupts are desired, set the TXIE bit of the PIE1 register and the GIE and PEIE bits of the INTCON register.
5. If 9-bit transmission is desired, set the TX9 bit.
6. Enable transmission by setting the TXEN bit.
7. If 9-bit transmission is selected, insert the Most Significant bit into the TX9D bit.
8. Start transmission by writing the Least Significant eight bits to the TXREG register.

TABLE 21-9: SUMMARY OF REGISTERS ASSOCIATED WITH SYNCHRONOUS SLAVE TRANSMISSION

Name	Bit 7	Bit 6	Bit 5	Bit 4	Bit 3	Bit 2	Bit 1	Bit 0	Register on Page
BAUDCON	ABDOVF	RCIDL	—	SCKP	BRG16	—	WUE	ABDEN	245
INTCON	GIE	PEIE	TMR0IE	INTE	IOCIE	TMR0IF	INTF	IOCIF	77
PIE1	TMR1GIE	AD1IE	RCIE	TXIE	SSP1IE	—	TMR2IE	TMR1IE	78
PIR1	TMR1GIF	AD1IF	RCIF	TXIF	SSP1IF	—	TMR2IF	TMR1IF	80
RCSTA	SPEN	RX9	SREN	CREN	ADDEN	FERR	OERR	RX9D	244
TRISB	TRISB7	TRISB6	TRISB5	TRISB4	—	—	—	—	112
TXREG	EUSART Transmit Data Register								236*
TXSTA	CSRC	TX9	TXEN	SYNC	SENDB	BRGH	TRMT	TX9D	243

Legend: — = unimplemented location, read as ‘0’. Shaded cells are not used for synchronous slave transmission.

* Page provides register information.

PIC16LF1554/1559

21.5.2.3 EUSART Synchronous Slave Reception

The operation of the Synchronous Master and Slave modes is identical ([Section 21.5.1.5 “Synchronous Master Reception”](#)), with the following exceptions:

- Sleep
- CREN bit is always set, therefore the receiver is never idle
- SREN bit, which is a “don’t care” in Slave mode

A character may be received while in Sleep mode by setting the CREN bit prior to entering Sleep. Once the word is received, the RSR register will transfer the data to the RCREG register. If the RCIE enable bit is set, the interrupt generated will wake the device from Sleep and execute the next instruction. If the GIE bit is also set, the program will branch to the interrupt vector.

21.5.2.4 Synchronous Slave Reception Set-up:

1. Set the SYNC and SPEN bits and clear the CSRC bit.
2. Clear the ANSELx bit for both the CK and DT pins (if applicable).
3. If interrupts are desired, set the RCIE bit of the PIE1 register and the GIE and PEIE bits of the INTCON register.
4. If 9-bit reception is desired, set the RX9 bit.
5. Set the CREN bit to enable reception.
6. The RCIF bit will be set when reception is complete. An interrupt will be generated if the RCIE bit was set.
7. If 9-bit mode is enabled, retrieve the Most Significant bit from the RX9D bit of the RCSTA register.
8. Retrieve the eight Least Significant bits from the receive FIFO by reading the RCREG register.
9. If an overrun error occurs, clear the error by either clearing the CREN bit of the RCSTA register or by clearing the SPEN bit which resets the EUSART.

TABLE 21-10: SUMMARY OF REGISTERS ASSOCIATED WITH SYNCHRONOUS SLAVE RECEPTION

Name	Bit 7	Bit 6	Bit 5	Bit 4	Bit 3	Bit 2	Bit 1	Bit 0	Register on Page
BAUDCON	ABDOVF	RCIDL	—	SCKP	BRG16	—	WUE	ABDEN	245
INTCON	GIE	PEIE	TMR0IE	INTE	IOCIE	TMR0IF	INTF	IOCIF	77
PIE1	TMR1GIE	AD1IE	RCIE	TXIE	SSP1IE	—	TMR2IE	TMR1IE	78
PIR1	TMR1GIF	AD1IF	RCIF	TXIF	SSP1IF	—	TMR2IF	TMR1IF	80
RCREG	EUSART Receive Data Register								239*
RCSTA	SPEN	RX9	SREN	CREN	ADDEN	FERR	OERR	RX9D	244
TRISB	TRISB7	TRISB6	TRISB5	TRISB4	—	—	—	—	112
TXSTA	CSRC	TX9	TXEN	SYNC	SEENDB	BRGH	TRMT	TX9D	243

Legend: — = unimplemented location, read as ‘0’. Shaded cells are not used for synchronous slave reception.

* Page provides register information.

22.0 PULSE-WIDTH MODULATION (PWM) MODULE

The PWM module generates a pulse-width modulated signal determined by the duty cycle, period, and resolution that are configured by the following registers:

- PR2
- T2CON
- PWMxDCH
- PWMxDCL
- PWMxCON

Figure 22-1 shows a simplified block diagram of PWM operation.

For a step-by-step procedure on how to set up this module for PWM operation, refer to [Section 22.1.9](#) “Setup for PWM Operation Using PWMx Pins”.

FIGURE 22-1: SIMPLIFIED PWM BLOCK DIAGRAM

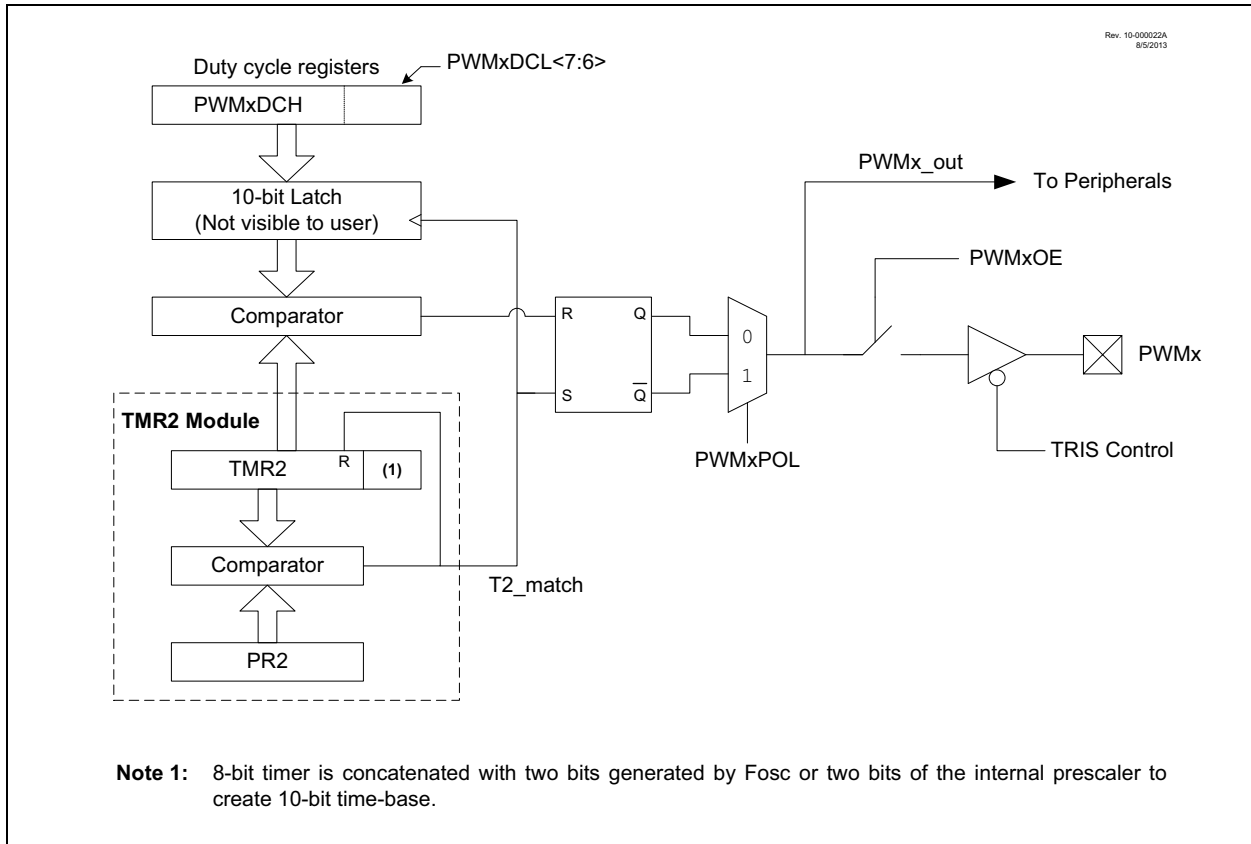

PIC16LF1554/1559

22.1 PWMx Pin Configuration

All PWM outputs are multiplexed with the PORT data latch. The user must configure the pins as outputs by clearing the associated TRISx bits.

Note: Clearing the PWMxOE bit will relinquish control of the PWMx pin.

22.1.1 FUNDAMENTAL OPERATION

The PWM module produces a 10-bit resolution output. Timer2 and PR2 set the period of the PWM. The PWMxDCL and PWMxDCH registers configure the duty cycle. The period is common to all PWM modules, whereas the duty cycle is independently controlled.

Note: The Timer2 postscaler is not used in the determination of the PWM frequency. The postscaler could be used to have a servo update rate at a different frequency than the PWM output.

All PWM outputs associated with Timer2 are set when TMR2 is cleared. Each PWMx is cleared when TMR2 is equal to the value specified in the corresponding PWMxDCH (8 MSb) and PWMxDCL<7:6> (2 LSB) registers. When the value is greater than or equal to PR2, the PWM output is never cleared (100% duty cycle).

Note: The PWMxDCH and PWMxDCL registers are double buffered. The buffers are updated when Timer2 matches PR2. Care should be taken to update both registers before the timer match occurs.

22.1.2 PWM OUTPUT POLARITY

The output polarity is inverted by setting the PWMxPOL bit of the PWMxCON register.

22.1.3 PWM PERIOD

The PWM period is specified by the PR2 register of Timer2. The PWM period can be calculated using the formula of Equation 22-1.

EQUATION 22-1: PWM PERIOD

$$PWM\ Period = [(PR2) + 1]^2 \cdot 4^2 \cdot TOSC^2$$

(TMR2 Prescale Value)

Note: TOSC = 1/FOSC

When TMR2 is equal to PR2, the following three events occur on the next increment cycle:

- TMR2 is cleared
- The PWM output is active (Exception: When the PWM duty cycle = 0%, the PWM output will remain inactive.)
- The PWMxDCH and PWMxDCL register values are latched into the buffers.

Note: The Timer2 postscaler has no effect on the PWM operation.

22.1.4 PWM DUTY CYCLE

The PWM duty cycle is specified by writing a 10-bit value to the PWMxDCH and PWMxDCL register pair. The PWMxDCH register contains the eight MSBs and the PWMxDCL<7:6>, the two LSBs. The PWMxDCH and PWMxDCL registers can be written to at any time.

Equation 22-2 is used to calculate the PWM pulse width.

Equation 22-3 is used to calculate the PWM duty cycle ratio.

EQUATION 22-2: PULSE WIDTH

$$Pulse\ Width = (PWMxDCH:PWMxDCL<7:6>) \cdot TOSC \cdot (TMR2\ Prescale\ Value)$$

Note: TOSC = 1/FOSC

EQUATION 22-3: DUTY CYCLE RATIO

$$Duty\ Cycle\ Ratio = \frac{(PWMxDCH:PWMxDCL<7:6>)}{4(PR2 + 1)}$$

The 8-bit timer TMR2 register is concatenated with the two Least Significant bits of 1/FOSC, adjusted by the Timer2 prescaler to create the 10-bit time base. The system clock is used if the Timer2 prescaler is set to 1:1.

Figure 22-2 shows a waveform of the PWM signal when the duty cycle is set for the smallest possible pulse.

FIGURE 22-2: PWM OUTPUT

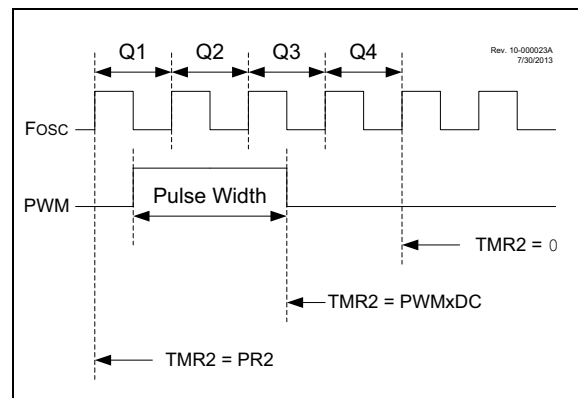

22.1.5 PWM RESOLUTION

The resolution determines the number of available duty cycles for a given period. For example, a 10-bit resolution will result in 1024 discrete duty cycles, whereas an 8-bit resolution will result in 256 discrete duty cycles.

The maximum PWM resolution is ten bits when PR2 is 255. The resolution is a function of the PR2 register value as shown by [Equation 22-4](#).

EQUATION 22-4: PWM RESOLUTION

$$Resolution = \frac{\log[4(PR2 + 1)]}{\log(2)} \text{ bits}$$

Note: If the pulse width value is greater than the period the assigned PWM pin(s) will remain unchanged.

TABLE 22-1: EXAMPLE PWM FREQUENCIES AND RESOLUTIONS (Fosc = 32 MHz)

PWM Frequency	1.95 kHz	7.81 kHz	31.25 kHz	125 kHz	250 kHz	333.3 kHz
Timer Prescale (1, 4, 16)	16	4	1	1	1	1
PRx Value	0xFF	0xFF	0xFF	0x3F	0x1F	0x17
Maximum Resolution (bits)	10	10	10	8	7	6.6

TABLE 22-2: EXAMPLE PWM FREQUENCIES AND RESOLUTIONS (Fosc = 20 MHz)

PWM Frequency	0.31 kHz	4.88 kHz	19.53 kHz	78.12 kHz	156.3 kHz	208.3 kHz
Timer Prescale	64	4	1	1	1	1
PR2 Value	0xFF	0xFF	0xFF	0x3F	0x1F	0x17
Maximum Resolution (bits)	10	10	10	8	7	6.6

TABLE 22-3: EXAMPLE PWM FREQUENCIES AND RESOLUTIONS (Fosc = 8 MHz)

PWM Frequency	0.31 kHz	4.90 kHz	19.61 kHz	76.92 kHz	153.85 kHz	200.0 kHz
Timer Prescale	64	4	1	1	1	1
PR2 Value	0x65	0x65	0x65	0x19	0x0C	0x09
Maximum Resolution (bits)	8	8	8	6	5	5

22.1.6 OPERATION IN SLEEP MODE

In Sleep mode, the TMR2 register will not increment and the state of the module will not change. If the PWMx pin is driving a value, it will continue to drive that value. When the device wakes up, TMR2 will continue from its previous state.

22.1.7 CHANGES IN SYSTEM CLOCK FREQUENCY

The PWM frequency is derived from the system clock frequency (Fosc). Any changes in the system clock frequency will result in changes to the PWM frequency. Refer to [Section 5.0 “Oscillator Module”](#) for additional details.

22.1.8 EFFECTS OF RESET

Any Reset will force all ports to Input mode and the PWM registers to their Reset states.

PIC16LF1554/1559

22.1.9 SETUP FOR PWM OPERATION USING PWMx PINS

The following steps should be taken when configuring the module for PWM operation using the PWMx pins:

1. Disable the PWMx pin output driver(s) by setting the associated TRISx bit(s).
2. Clear the PWMxCON register.
3. Load the PR2 register with the PWM period value.
4. Clear the PWMxDCH register and bits <7:6> of the PWMxDCL register.
5. Configure and start Timer2:
 - Clear the TMR2IF interrupt flag bit of the PIR1 register. See note below.
 - Configure the T2CKPS bits of the T2CON register with the Timer2 prescale value.
 - Enable Timer2 by setting the TMR2ON bit of the T2CON register.
6. Enable PWM output pin and wait until Timer2 overflows, TMR2IF bit of the PIR1 register is set. See note below.
7. Enable the PWMx pin output driver(s) by clearing the associated TRISx bit(s) and setting the PWMxOE bit of the PWMxCON register.
8. Configure the PWM module by loading the PWMxCON register with the appropriate values.

Note 1: In order to send a complete duty cycle and period on the first PWM output, the above steps must be followed in the order given. If it is not critical to start with a complete PWM signal, then move Step 8 to replace Step 4.

2: For operation with other peripherals only, disable PWMx pin outputs.

22.2 Register Definitions: PWM Control

REGISTER 22-1: PWMxCON: PWM CONTROL REGISTER

R/W-0/0	R/W-0/0	R-0/0	R/W-0/0	U-0	U-0	U-0	U-0
PWMxEN	PWMxOE	PWMxOUT	PWMxPOL	—	—	—	—
bit 7							bit 0

Legend:

R = Readable bit	W = Writable bit	U = Unimplemented bit, read as '0'
u = Bit is unchanged	x = Bit is unknown	-n/n = Value at POR and BOR/Value at all other Resets
'1' = Bit is set	'0' = Bit is cleared	

- bit 7 **PWMxEN:** PWM Module Enable bit
 1 = PWM module is enabled
 0 = PWM module is disabled
- bit 6 **PWMxOE:** PWM Module Output Enable bit
 1 = Output to PWMx pin is enabled
 0 = Output to PWMx pin is disabled
- bit 5 **PWMxOUT:** PWM Module Output Value bit
- bit 4 **PWMxPOL:** PWMx Output Polarity Select bit
 1 = PWM output is active-low
 0 = PWM output is active-high
- bit 3-0 **Unimplemented:** Read as '0'

REGISTER 22-2: PWMxDCH: PWM DUTY CYCLE HIGH BITS

R/W-x/u	R/W-x/u	R/W-x/u	R/W-x/u	R/W-x/u	R/W-x/u	R/W-x/u	R/W-x/u
PWMxDCH<7:0>							
bit 7							bit 0

Legend:

R = Readable bit	W = Writable bit	U = Unimplemented bit, read as '0'
u = Bit is unchanged	x = Bit is unknown	-n/n = Value at POR and BOR/Value at all other Resets
'1' = Bit is set	'0' = Bit is cleared	

- bit 7-0 **PWMxDCH<7:0>:** PWM Duty Cycle Most Significant bits
 These bits are the MSBs of the PWM duty cycle. The two LSBs are found in the PWMxDCL register.

PIC16LF1554/1559

REGISTER 22-3: PWMxDCL: PWM DUTY CYCLE LOW BITS

R/W-x/u	R/W-x/u	U-0	U-0	U-0	U-0	U-0	U-0
PWMxDCL<7:6>	—	—	—	—	—	—	—
bit 7							bit 0

Legend:

R = Readable bit W = Writable bit U = Unimplemented bit, read as '0'
u = Bit is unchanged x = Bit is unknown -n/n = Value at POR and BOR/Value at all other Resets
'1' = Bit is set '0' = Bit is cleared

bit 7-6 **PWMxDCL<7:6>**: PWM Duty Cycle Least Significant bits
These bits are the LSbs of the PWM duty cycle. The MSbs are found in the PWMxDCH register.
bit 5-0 **Unimplemented**: Read as '0'

TABLE 22-4: SUMMARY OF REGISTERS ASSOCIATED WITH PWM

Name	Bit 7	Bit 6	Bit 5	Bit 4	Bit 3	Bit 2	Bit 1	Bit 0	Register on Page
PR2	Timer2 module Period Register								178*
PWM1CON	PWM1EN	PWM1OE	PWM1OUT	PWM1POL	—	—	—	—	265
PWM1DCH	PWM1DCH<7:0>								265
PWM1DCL	PWM1DCL<7:6>	—	—	—	—	—	—	—	266
PWM2CON	PWM2EN	PWM2OE	PWM2OUT	PWM2POL	—	—	—	—	265
PWM2DCH	PWM2DCH<7:0>								265
PWM2DCL	PWM2DCL<7:6>	—	—	—	—	—	—	—	266
T2CON	—	T2OUTPS<3:0>				TMR2ON	T2CKPS<1:0>		180
TMR2	Timer2 module Register								178*
TRISA	—	—	TRISA5	TRISA4	— ⁽¹⁾	TRISA2	TRISA1	TRISA0	108
TRISC	TRISC7	TRISC6	TRISC5	TRISC4	TRISC3	TRISC2	TRISC1	TRISC0	116

Legend: — = Unimplemented locations, read as '0', u = unchanged, x = unknown. Shaded cells are not used by the PWM.

* Page provides register information.

Note 1: Unimplemented, read as '1'.

23.0 IN-CIRCUIT SERIAL PROGRAMMING™ (ICSP™)

ICSP™ programming allows customers to manufacture circuit boards with unprogrammed devices. Programming can be done after the assembly process allowing the device to be programmed with the most recent firmware or a custom firmware. Five pins are needed for ICSP™ programming:

- ICSPCLK
- ICSPDAT
- MCLR/VPP
- VDD
- VSS

In Program/Verify mode the program memory, user IDs and the Configuration Words are programmed through serial communications. The ICSPDAT pin is a bidirectional I/O used for transferring the serial data and the ICSPCLK pin is the clock input. For more information on ICSP™ refer to the “PIC12(L)F1501/PIC16(L)F150X Memory Programming Specification” (DS41573).

23.1 High-Voltage Programming Entry Mode

The device is placed into High-Voltage Programming Entry mode by holding the ICSPCLK and ICSPDAT pins low then raising the voltage on MCLR/VPP to VIH.

23.2 Low-Voltage Programming Entry Mode

The Low-Voltage Programming Entry mode allows the PIC® Flash MCUs to be programmed using VDD only, without high voltage. When the LVP bit of Configuration Words is set to ‘1’, the ICSP Low-Voltage Programming Entry mode is enabled. To disable the Low-Voltage ICSP mode, the LVP bit must be programmed to ‘0’.

Entry into the Low-Voltage Programming Entry mode requires the following steps:

1. MCLR is brought to VIL.
2. A 32-bit key sequence is presented on ICSPDAT, while clocking ICSPCLK.

Once the key sequence is complete, MCLR must be held at VIL for as long as Program/Verify mode is to be maintained.

If low-voltage programming is enabled (LVP = 1), the MCLR Reset function is automatically enabled and cannot be disabled. See Section 6.5 “MCLR” for more information.

The LVP bit can only be reprogrammed to ‘0’ by using the High-Voltage Programming mode.

23.3 Common Programming Interfaces

Connection to a target device is typically done through an ICSP™ header. A commonly found connector on development tools is the RJ-11 in the 6P6C (6-pin, 6-connector) configuration. See Figure 23-1.

FIGURE 23-1: ICD RJ-11 STYLE CONNECTOR INTERFACE

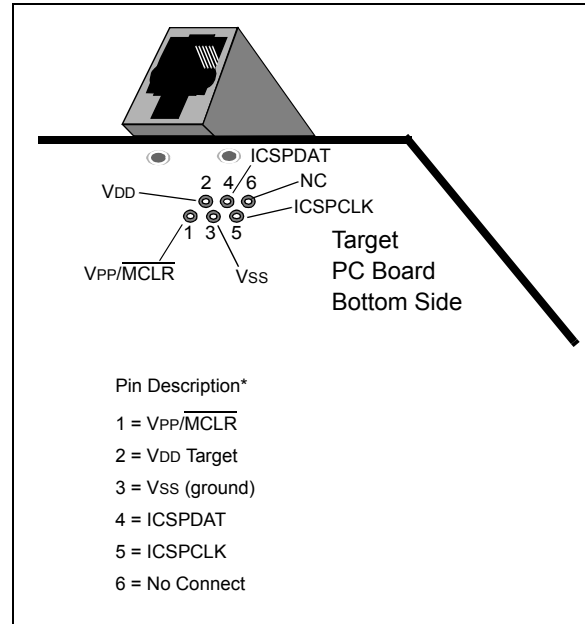

Another connector often found in use with the PICkit™ programmers is a standard 6-pin header with 0.1 inch spacing. Refer to Figure 23-2.

PIC16LF1554/1559

FIGURE 23-2: PICKIT™ PROGRAMMER STYLE CONNECTOR INTERFACE

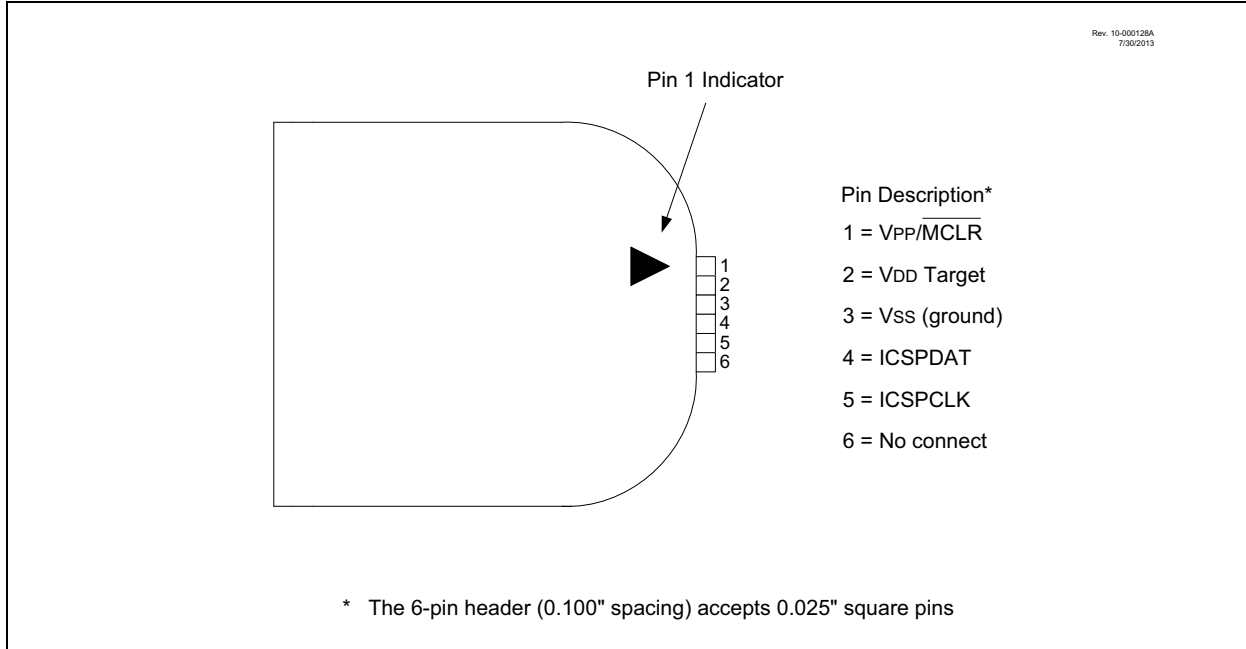

For additional interface recommendations, refer to your specific device programmer manual prior to PCB design.

It is recommended that isolation devices be used to separate the programming pins from other circuitry. The type of isolation is highly dependent on the specific application and may include devices such as resistors, diodes, or even jumpers. See [Figure 23-3](#) for more information.

FIGURE 23-3: TYPICAL CONNECTION FOR ICSP™ PROGRAMMING

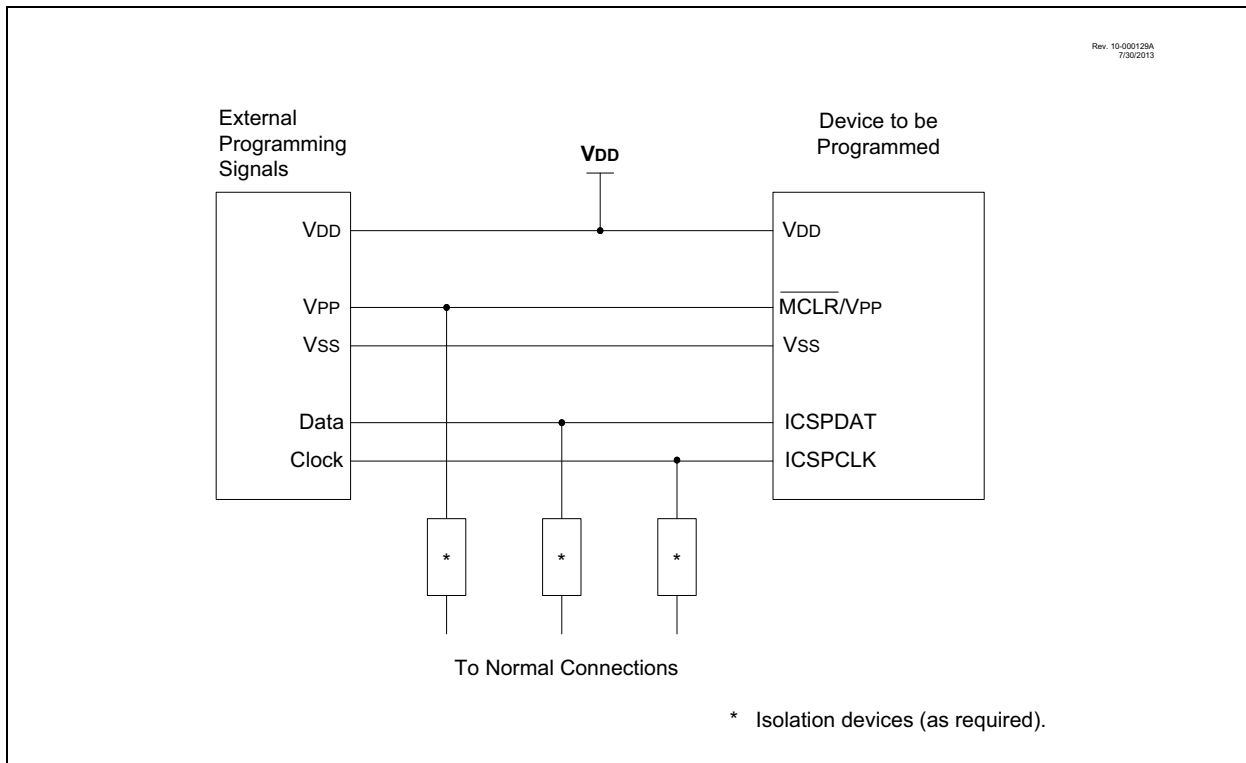

24.0 INSTRUCTION SET SUMMARY

Each instruction is a 14-bit word containing the operation code (opcode) and all required operands. The opcodes are broken into three broad categories.

- Byte Oriented
- Bit Oriented
- Literal and Control

The literal and control category contains the most varied instruction word format.

Table lists the instructions recognized by the MPASM™ assembler.

All instructions are executed within a single instruction cycle, with the following exceptions, which may take two or three cycles:

- Subroutine takes two cycles (CALL, CALLW)
- Returns from interrupts or subroutines take two cycles (RETURN, RETLW, RETFIE)
- Program branching takes two cycles (GOTO, BRA, BRW, BTFSS, BTFSC, DECFSZ, INCSFZ)
- One additional instruction cycle will be used when any instruction references an indirect file register and the file select register is pointing to program memory.

One instruction cycle consists of 4 oscillator cycles; for an oscillator frequency of 4 MHz, this gives a nominal instruction execution rate of 1 MHz.

All instruction examples use the format '0xhh' to represent a hexadecimal number, where 'h' signifies a hexadecimal digit.

24.1 Read-Modify-Write Operations

Any instruction that specifies a file register as part of the instruction performs a Read-Modify-Write (R-M-W) operation. The register is read, the data is modified, and the result is stored according to either the instruction, or the destination designator 'd'. A read operation is performed on a register even if the instruction writes to that register.

TABLE 24-1: OPCODE FIELD DESCRIPTIONS

Field	Description
f	Register file address (0x00 to 0x7F)
W	Working register (accumulator)
b	Bit address within an 8-bit file register
k	Literal field, constant data or label
x	Don't care location (= 0 or 1). The assembler will generate code with x = 0. It is the recommended form of use for compatibility with all Microchip software tools.
d	Destination select; d = 0: store result in W, d = 1: store result in file register f. Default is d = 1.
n	FSR or INDF number (0-1)
mm	Pre-post increment-decrement mode selection

TABLE 24-2: ABBREVIATION DESCRIPTIONS

Field	Description
PC	Program Counter
\overline{TO}	Time-Out bit
C	Carry bit
DC	Digit Carry bit
Z	Zero bit
\overline{PD}	Power-Down bit

PIC16LF1554/1559

FIGURE 24-1: GENERAL FORMAT FOR INSTRUCTIONS

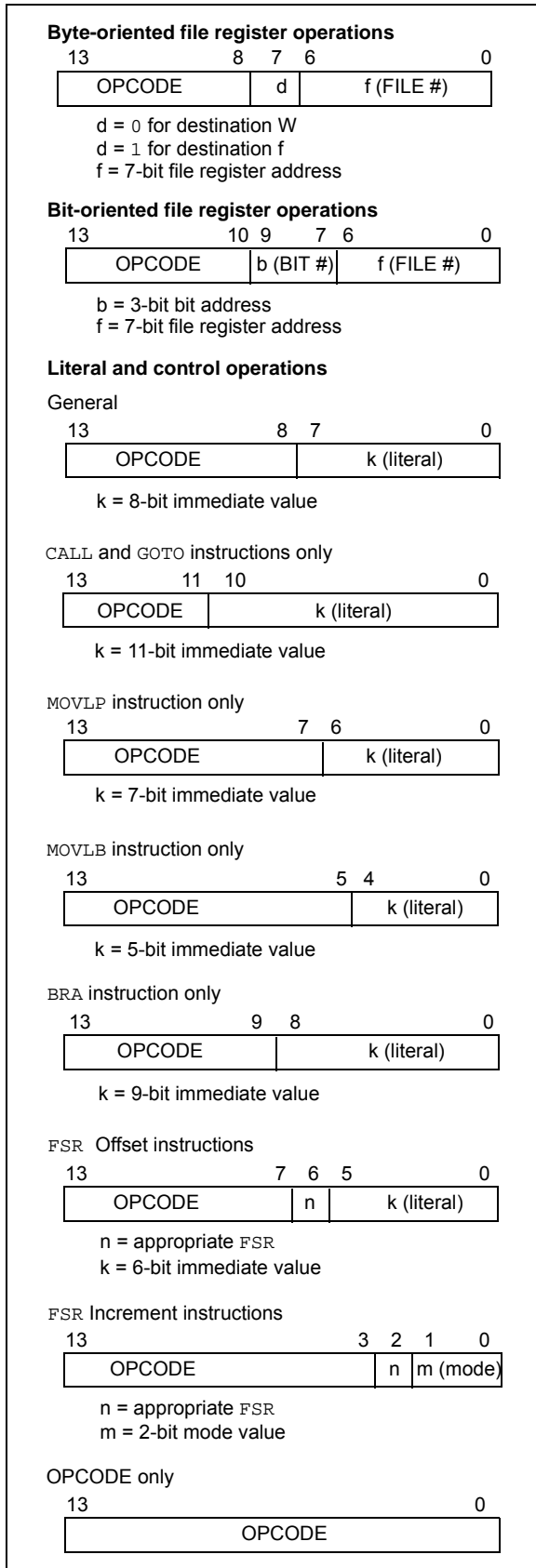

TABLE 24-3: ENHANCED MID-RANGE INSTRUCTION SET

Mnemonic, Operands	Description	Cycles	14-Bit Opcode				Status Affected	Notes	
			MSb	LSb					
BYTE-ORIENTED FILE REGISTER OPERATIONS									
ADDWF	f, d	Add W and f	1	00	0111	dfff	ffff	C, DC, Z	2
ADDWFC	f, d	Add with Carry W and f	1	11	1101	dfff	ffff	C, DC, Z	2
ANDWF	f, d	AND W with f	1	00	0101	dfff	ffff	Z	2
ASRF	f, d	Arithmetic Right Shift	1	11	0111	dfff	ffff	C, Z	2
LSLF	f, d	Logical Left Shift	1	11	0101	dfff	ffff	C, Z	2
LSRF	f, d	Logical Right Shift	1	11	0110	dfff	ffff	C, Z	2
CLRF	f	Clear f	1	00	0001	1fff	ffff	Z	2
CLRW	–	Clear W	1	00	0001	0000	00xx	Z	
COMF	f, d	Complement f	1	00	1001	dfff	ffff	Z	2
DECF	f, d	Decrement f	1	00	0011	dfff	ffff	Z	2
INCF	f, d	Increment f	1	00	1010	dfff	ffff	Z	2
IORWF	f, d	Inclusive OR W with f	1	00	0100	dfff	ffff	Z	2
MOVF	f, d	Move f	1	00	1000	dfff	ffff	Z	2
MOVWF	f	Move W to f	1	00	0000	1fff	ffff		2
RLF	f, d	Rotate Left f through Carry	1	00	1101	dfff	ffff	C	2
RRF	f, d	Rotate Right f through Carry	1	00	1100	dfff	ffff	C	2
SUBWF	f, d	Subtract W from f	1	00	0010	dfff	ffff	C, DC, Z	2
SUBWFB	f, d	Subtract with Borrow W from f	1	11	1011	dfff	ffff	C, DC, Z	2
SWAPF	f, d	Swap nibbles in f	1	00	1110	dfff	ffff		2
XORWF	f, d	Exclusive OR W with f	1	00	0110	dfff	ffff	Z	2
BYTE ORIENTED SKIP OPERATIONS									
DECFSZ	f, d	Decrement f, Skip if 0	1(2)	00	1011	dfff	ffff		1, 2
INCFSZ	f, d	Increment f, Skip if 0	1(2)	00	1111	dfff	ffff		1, 2
BIT-ORIENTED FILE REGISTER OPERATIONS									
BCF	f, b	Bit Clear f	1	01	00bb	bfff	ffff		2
BSF	f, b	Bit Set f	1	01	01bb	bfff	ffff		2
BIT-ORIENTED SKIP OPERATIONS									
BTFSC	f, b	Bit Test f, Skip if Clear	1 (2)	01	10bb	bfff	ffff		1, 2
BTFSS	f, b	Bit Test f, Skip if Set	1 (2)	01	11bb	bfff	ffff		1, 2
LITERAL OPERATIONS									
ADDLW	k	Add literal and W	1	11	1110	kkkk	kkkk	C, DC, Z	
ANDLW	k	AND literal with W	1	11	1001	kkkk	kkkk	Z	
IORLW	k	Inclusive OR literal with W	1	11	1000	kkkk	kkkk	Z	
MOVLB	k	Move literal to BSR	1	00	0000	001k	kkkk		
MOVLP	k	Move literal to PCLATH	1	11	0001	1kkk	kkkk		
MOVLW	k	Move literal to W	1	11	0000	kkkk	kkkk		
SUBLW	k	Subtract W from literal	1	11	1100	kkkk	kkkk	C, DC, Z	
XORLW	k	Exclusive OR literal with W	1	11	1010	kkkk	kkkk	Z	

- Note** 1: If the Program Counter (PC) is modified, or a conditional test is true, the instruction requires two cycles. The second cycle is executed as a NOP.
- 2: If this instruction addresses an INDF register and the MSb of the corresponding FSR is set, this instruction will require one additional instruction cycle.
- 3: See Table in the MOVIW and MOVWI instruction descriptions.

PIC16LF1554/1559

TABLE 24-3: ENHANCED MID-RANGE INSTRUCTION SET (CONTINUED)

Mnemonic, Operands	Description	Cycles	14-Bit Opcode			Status Affected	Notes		
			MSb		LSb				
CONTROL OPERATIONS									
BRA	k	Relative Branch	2	11	001k	kkkk	kkkk		
BRW	–	Relative Branch with W	2	00	0000	0000	1011		
CALL	k	Call Subroutine	2	10	0kkk	kkkk	kkkk		
CALLW	–	Call Subroutine with W	2	00	0000	0000	1010		
GOTO	k	Go to address	2	10	1kkk	kkkk	kkkk		
RETFIE	–	Return from interrupt	2	00	0000	0000	1001		
RETLW	k	Return with literal in W	2	11	0100	kkkk	kkkk		
RETURN	–	Return from Subroutine	2	00	0000	0000	1000		
INHERENT OPERATIONS									
CLRWDT	–	Clear Watchdog Timer	1	00	0000	0110	0100	\overline{TO} , \overline{PD}	
NOP	–	No Operation	1	00	0000	0000	0000		
OPTION	–	Load OPTION_REG register with W	1	00	0000	0110	0010		
RESET	–	Software device Reset	1	00	0000	0000	0001		
SLEEP	–	Go into Standby mode	1	00	0000	0110	0011	\overline{TO} , \overline{PD}	
TRIS	f	Load TRIS register with W	1	00	0000	0110	0fff		
C-COMPILER OPTIMIZED									
ADDFSR	n, k	Add Literal k to FSRn	1	11	0001	0nkk	kkkk		
MOVIW	n mm	Move Indirect FSRn to W with pre/post inc/dec modifier, mm	1	00	0000	0001	0nmm kkkk	Z	2, 3
MOVWI	k[n]	Move INDFn to W, Indexed Indirect.	1	11	1111	0nkk	1nmm	Z	2
	n mm	Move W to Indirect FSRn with pre/post inc/dec modifier, mm	1	00	0000	0001	kkkk		2, 3
	k[n]	Move W to INDFn, Indexed Indirect.	1	11	1111	1nkk			2

- Note 1:** If the Program Counter (PC) is modified, or a conditional test is true, the instruction requires two cycles. The second cycle is executed as a NOP.
- Note 2:** If this instruction addresses an INDF register and the MSb of the corresponding FSR is set, this instruction will require one additional instruction cycle.
- Note 3:** See Table in the MOVIW and MOVWI instruction descriptions.

24.2 Instruction Descriptions

ADDFSR	Add Literal to FSRn
Syntax:	[<i>label</i>] ADDFSR FSRn, k
Operands:	-32 ≤ k ≤ 31 n ∈ [0, 1]
Operation:	FSR(n) + k → FSR(n)
Status Affected:	None
Description:	The signed 6-bit literal 'k' is added to the contents of the FSRnH:FSRnL register pair. FSRn is limited to the range 0000h - FFFFh. Moving beyond these bounds will cause the FSR to wrap-around.

ANDLW	AND literal with W
Syntax:	[<i>label</i>] ANDLW k
Operands:	0 ≤ k ≤ 255
Operation:	(W) .AND. (k) → (W)
Status Affected:	Z
Description:	The contents of W register are AND'ed with the 8-bit literal 'k'. The result is placed in the W register.

ADDLW	Add literal and W
Syntax:	[<i>label</i>] ADDLW k
Operands:	0 ≤ k ≤ 255
Operation:	(W) + k → (W)
Status Affected:	C, DC, Z
Description:	The contents of the W register are added to the 8-bit literal 'k' and the result is placed in the W register.

ANDWF	AND W with f
Syntax:	[<i>label</i>] ANDWF f,d
Operands:	0 ≤ f ≤ 127 d ∈ [0,1]
Operation:	(W) .AND. (f) → (destination)
Status Affected:	Z
Description:	AND the W register with register 'f'. If 'd' is '0', the result is stored in the W register. If 'd' is '1', the result is stored back in register 'f'.

ADDWF	Add W and f
Syntax:	[<i>label</i>] ADDWF f,d
Operands:	0 ≤ f ≤ 127 d ∈ [0,1]
Operation:	(W) + (f) → (destination)
Status Affected:	C, DC, Z
Description:	Add the contents of the W register with register 'f'. If 'd' is '0', the result is stored in the W register. If 'd' is '1', the result is stored back in register 'f'.

ASRF	Arithmetic Right Shift
Syntax:	[<i>label</i>] ASRF f {,d}
Operands:	0 ≤ f ≤ 127 d ∈ [0,1]
Operation:	(f<7>) → dest<7> (f<7:1>) → dest<6:0>, (f<0>) → C,
Status Affected:	C, Z
Description:	The contents of register 'f' are shifted one bit to the right through the Carry flag. The MSb remains unchanged. If 'd' is '0', the result is placed in W. If 'd' is '1', the result is stored back in register 'f'.

ADDWFC	ADD W and CARRY bit to f
Syntax:	[<i>label</i>] ADDWFC f {,d}
Operands:	0 ≤ f ≤ 127 d ∈ [0,1]
Operation:	(W) + (f) + (C) → dest
Status Affected:	C, DC, Z
Description:	Add W, the Carry flag and data memory location 'f'. If 'd' is '0', the result is placed in W. If 'd' is '1', the result is placed in data memory location 'f'.

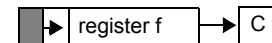

PIC16LF1554/1559

BCF Bit Clear f

Syntax: [*label*] BCF f,b
Operands: $0 \leq f \leq 127$
 $0 \leq b \leq 7$
Operation: $0 \rightarrow (f)$
Status Affected: None
Description: Bit 'b' in register 'f' is cleared.

BTFSC Bit Test f, Skip if Clear

Syntax: [*label*] BTFSC f,b
Operands: $0 \leq f \leq 127$
 $0 \leq b \leq 7$
Operation: skip if $(f) = 0$
Status Affected: None
Description: If bit 'b' in register 'f' is '1', the next instruction is executed.
If bit 'b', in register 'f', is '0', the next instruction is discarded, and a NOP is executed instead, making this a 2-cycle instruction.

BRA Relative Branch

Syntax: [*label*] BRA label
[*label*] BRA \$+k
Operands: $-256 \leq \text{label} - \text{PC} + 1 \leq 255$
 $-256 \leq k \leq 255$
Operation: $(\text{PC}) + 1 + k \rightarrow \text{PC}$
Status Affected: None
Description: Add the signed 9-bit literal 'k' to the PC. Since the PC will have incremented to fetch the next instruction, the new address will be $\text{PC} + 1 + k$. This instruction is a 2-cycle instruction. This branch has a limited range.

BTFSS Bit Test f, Skip if Set

Syntax: [*label*] BTFSS f,b
Operands: $0 \leq f \leq 127$
 $0 \leq b < 7$
Operation: skip if $(f) = 1$
Status Affected: None
Description: If bit 'b' in register 'f' is '0', the next instruction is executed.
If bit 'b' is '1', then the next instruction is discarded and a NOP is executed instead, making this a 2-cycle instruction.

BRW Relative Branch with W

Syntax: [*label*] BRW
Operands: None
Operation: $(\text{PC}) + (W) \rightarrow \text{PC}$
Status Affected: None
Description: Add the contents of W (unsigned) to the PC. Since the PC will have incremented to fetch the next instruction, the new address will be $\text{PC} + 1 + (W)$. This instruction is a 2-cycle instruction.

BSF Bit Set f

Syntax: [*label*] BSF f,b
Operands: $0 \leq f \leq 127$
 $0 \leq b \leq 7$
Operation: $1 \rightarrow (f)$
Status Affected: None
Description: Bit 'b' in register 'f' is set.

CALL Call Subroutine

Syntax:	[<i>label</i>] CALL <i>k</i>
Operands:	$0 \leq k \leq 2047$
Operation:	(PC)+ 1 → TOS, k → PC<10:0>, (PCLATH<6:3>) → PC<14:11>
Status Affected:	None
Description:	Call Subroutine. First, return address (PC + 1) is pushed onto the stack. The 11-bit immediate address is loaded into PC bits <10:0>. The upper bits of the PC are loaded from PCLATH. CALL is a 2-cycle instruction.

CLRWDT Clear Watchdog Timer

Syntax:	[<i>label</i>] CLRWDT
Operands:	None
Operation:	00h → WDT 0 → WDT prescaler, 1 → \overline{TO} 1 → \overline{PD}
Status Affected:	\overline{TO} , \overline{PD}
Description:	CLRWDT instruction resets the Watchdog Timer. It also resets the prescaler of the WDT. Status bits \overline{TO} and \overline{PD} are set.

CALLW Subroutine Call With W

Syntax:	[<i>label</i>] CALLW
Operands:	None
Operation:	(PC) + 1 → TOS, (W) → PC<7:0>, (PCLATH<6:0>) → PC<14:8>
Status Affected:	None
Description:	Subroutine call with W. First, the return address (PC + 1) is pushed onto the return stack. Then, the contents of W is loaded into PC<7:0>, and the contents of PCLATH into PC<14:8>. CALLW is a 2-cycle instruction.

COMF Complement f

Syntax:	[<i>label</i>] COMF <i>f</i> , <i>d</i>
Operands:	$0 \leq f \leq 127$ $d \in [0,1]$
Operation:	\bar{f} → (destination)
Status Affected:	Z
Description:	The contents of register 'f' are complemented. If 'd' is '0', the result is stored in W. If 'd' is '1', the result is stored back in register 'f'.

CLRF Clear f

Syntax:	[<i>label</i>] CLRF <i>f</i>
Operands:	$0 \leq f \leq 127$
Operation:	00h → (f) 1 → Z
Status Affected:	Z
Description:	The contents of register 'f' are cleared and the Z bit is set.

DECF Decrement f

Syntax:	[<i>label</i>] DECF <i>f</i> , <i>d</i>
Operands:	$0 \leq f \leq 127$ $d \in [0,1]$
Operation:	(f) - 1 → (destination)
Status Affected:	Z
Description:	Decrement register 'f'. If 'd' is '0', the result is stored in the W register. If 'd' is '1', the result is stored back in register 'f'.

CLRW Clear W

Syntax:	[<i>label</i>] CLRW
Operands:	None
Operation:	00h → (W) 1 → Z
Status Affected:	Z
Description:	W register is cleared. Zero bit (Z) is set.

PIC16LF1554/1559

DECFSZ **Decrement f, Skip if 0**

Syntax: [*label*] DECFSZ f,d

Operands: $0 \leq f \leq 127$
 $d \in [0,1]$

Operation: (f) - 1 → (destination);
 skip if result = 0

Status Affected: None

Description: The contents of register 'f' are decremented. If 'd' is '0', the result is placed in the W register. If 'd' is '1', the result is placed back in register 'f'. If the result is '1', the next instruction is executed. If the result is '0', then a NOP is executed instead, making it a 2-cycle instruction.

INCFSZ **Increment f, Skip if 0**

Syntax: [*label*] INCFSZ f,d

Operands: $0 \leq f \leq 127$
 $d \in [0,1]$

Operation: (f) + 1 → (destination),
 skip if result = 0

Status Affected: None

Description: The contents of register 'f' are incremented. If 'd' is '0', the result is placed in the W register. If 'd' is '1', the result is placed back in register 'f'. If the result is '1', the next instruction is executed. If the result is '0', a NOP is executed instead, making it a 2-cycle instruction.

GOTO **Unconditional Branch**

Syntax: [*label*] GOTO k

Operands: $0 \leq k \leq 2047$

Operation: $k \rightarrow PC<10:0>$
 $PCLATH<6:3> \rightarrow PC<14:11>$

Status Affected: None

Description: GOTO is an unconditional branch. The 11-bit immediate value is loaded into PC bits <10:0>. The upper bits of PC are loaded from PCLATH<4:3>. GOTO is a 2-cycle instruction.

IORLW **Inclusive OR literal with W**

Syntax: [*label*] IORLW k

Operands: $0 \leq k \leq 255$

Operation: (W) .OR. k → (W)

Status Affected: Z

Description: The contents of the W register are OR'ed with the 8-bit literal 'k'. The result is placed in the W register.

INCF **Increment f**

Syntax: [*label*] INCF f,d

Operands: $0 \leq f \leq 127$
 $d \in [0,1]$

Operation: (f) + 1 → (destination)

Status Affected: Z

Description: The contents of register 'f' are incremented. If 'd' is '0', the result is placed in the W register. If 'd' is '1', the result is placed back in register 'f'.

IORWF **Inclusive OR W with f**

Syntax: [*label*] IORWF f,d

Operands: $0 \leq f \leq 127$
 $d \in [0,1]$

Operation: (W) .OR. (f) → (destination)

Status Affected: Z

Description: Inclusive OR the W register with register 'f'. If 'd' is '0', the result is placed in the W register. If 'd' is '1', the result is placed back in register 'f'.

LSLF **Logical Left Shift**

Syntax: `[label] LSLF f {,d}`

Operands: $0 \leq f \leq 127$
 $d \in [0,1]$

Operation: $(f<7>) \rightarrow C$
 $(f<6:0>) \rightarrow \text{dest}<7:1>$
 $0 \rightarrow \text{dest}<0>$

Status Affected: C, Z

Description: The contents of register 'f' are shifted one bit to the left through the Carry flag. A '0' is shifted into the LSb. If 'd' is '0', the result is placed in W. If 'd' is '1', the result is stored back in register 'f'.

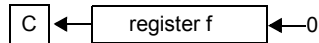

LSRF **Logical Right Shift**

Syntax: `[label] LSRF f {,d}`

Operands: $0 \leq f \leq 127$
 $d \in [0,1]$

Operation: $0 \rightarrow \text{dest}<7>$
 $(f<7:1>) \rightarrow \text{dest}<6:0>$,
 $(f<0>) \rightarrow C$,

Status Affected: C, Z

Description: The contents of register 'f' are shifted one bit to the right through the Carry flag. A '0' is shifted into the MSb. If 'd' is '0', the result is placed in W. If 'd' is '1', the result is stored back in register 'f'.

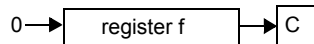

MOVF **Move f**

Syntax: `[label] MOVF f,d`

Operands: $0 \leq f \leq 127$
 $d \in [0,1]$

Operation: $(f) \rightarrow (\text{dest})$

Status Affected: Z

Description: The contents of register f is moved to a destination dependent upon the status of d. If d = 0, destination is W register. If d = 1, the destination is file register f itself. d = 1 is useful to test a file register since status flag Z is affected.

Words: 1

Cycles: 1

Example: `MOVF FSR, 0`

After Instruction
 $W = \text{value in FSR register}$
 $Z = 1$

PIC16LF1554/1559

MOVIW **Move INDFn to W**

Syntax: [*label*] MOVIW ++FSRn
 [*label*] MOVIW --FSRn
 [*label*] MOVIW FSRn++
 [*label*] MOVIW FSRn--
 [*label*] MOVIW k[FSRn]

Operands: $n \in [0,1]$
 $mm \in [00,01, 10, 11]$
 $-32 \leq k \leq 31$

Operation: INDFn \rightarrow W
 Effective address is determined by

- FSR + 1 (preincrement)
- FSR - 1 (predecrement)
- FSR + k (relative offset)

After the Move, the FSR value will be either:

- FSR + 1 (all increments)
- FSR - 1 (all decrements)
- Unchanged

Status Affected: Z

Mode	Syntax	mm
Preincrement	++FSRn	00
Predecrement	--FSRn	01
Postincrement	FSRn++	10
Postdecrement	FSRn--	11

Description: This instruction is used to move data between W and one of the indirect registers (INDFn). Before/after this move, the pointer (FSRn) is updated by pre/post incrementing/decrementing it.

Note: The INDFn registers are not physical registers. Any instruction that accesses an INDFn register actually accesses the register at the address specified by the FSRn.

FSRn is limited to the range 0000h - FFFFh. Incrementing/decrementing it beyond these bounds will cause it to wrap-around.

MOVLB **Move literal to BSR**

Syntax: [*label*] MOVLB k

Operands: $0 \leq k \leq 31$

Operation: $k \rightarrow$ BSR

Status Affected: None

Description: The 5-bit literal 'k' is loaded into the Bank Select Register (BSR).

MOVLP **Move literal to PCLATH**

Syntax: [*label*] MOVLP k

Operands: $0 \leq k \leq 127$

Operation: $k \rightarrow$ PCLATH

Status Affected: None

Description: The 7-bit literal 'k' is loaded into the PCLATH register.

MOVLW **Move literal to W**

Syntax: [*label*] MOVLW k

Operands: $0 \leq k \leq 255$

Operation: $k \rightarrow$ (W)

Status Affected: None

Description: The 8-bit literal 'k' is loaded into W register. The "don't cares" will assemble as '0's.

Words: 1

Cycles: 1

Example: MOV LW 0x5A
 After Instruction
 W = 0x5A

MOVWF **Move W to f**

Syntax: [*label*] MOVWF f

Operands: $0 \leq f \leq 127$

Operation: (W) \rightarrow (f)

Status Affected: None

Description: Move data from W register to register 'f'.

Words: 1

Cycles: 1

Example: MOVWF OPTION_REG
 Before Instruction
 OPTION_REG = 0xFF
 W = 0x4F
 After Instruction
 OPTION_REG = 0x4F
 W = 0x4F

MOVWI	Move W to INDFn
Syntax:	[<i>label</i>] MOVWI ++FSRn [<i>label</i>] MOVWI --FSRn [<i>label</i>] MOVWI FSRn++ [<i>label</i>] MOVWI FSRn-- [<i>label</i>] MOVWI k[FSRn]
Operands:	n ∈ [0,1] mm ∈ [00,01, 10, 11] -32 ≤ k ≤ 31
Operation:	W → INDFn Effective address is determined by <ul style="list-style-type: none"> • FSR + 1 (preincrement) • FSR - 1 (predecrement) • FSR + k (relative offset) After the Move, the FSR value will be either: <ul style="list-style-type: none"> • FSR + 1 (all increments) • FSR - 1 (all decrements) Unchanged
Status Affected:	None

Mode	Syntax	mm
Preincrement	++FSRn	00
Predecrement	--FSRn	01
Postincrement	FSRn++	10
Postdecrement	FSRn--	11

Description: This instruction is used to move data between W and one of the indirect registers (INDFn). Before/after this move, the pointer (FSRn) is updated by pre/post incrementing/decrementing it.

Note: The INDFn registers are not physical registers. Any instruction that accesses an INDFn register actually accesses the register at the address specified by the FSRn.

FSRn is limited to the range 0000h - FFFFh. Incrementing/decrementing it beyond these bounds will cause it to wrap-around.

The increment/decrement operation on FSRn WILL NOT affect any Status bits.

NOP	No Operation
Syntax:	[<i>label</i>] NOP
Operands:	None
Operation:	No operation
Status Affected:	None
Description:	No operation.
Words:	1
Cycles:	1
Example:	NOP

OPTION	Load OPTION_REG Register with W
Syntax:	[<i>label</i>] OPTION
Operands:	None
Operation:	(W) → OPTION_REG
Status Affected:	None
Description:	Move data from W register to OPTION_REG register.

RESET	Software Reset
Syntax:	[<i>label</i>] RESET
Operands:	None
Operation:	Execute a device Reset. Resets the RI flag of the PCON register.
Status Affected:	None
Description:	This instruction provides a way to execute a hardware Reset by software.

PIC16LF1554/1559

RETFIE **Return from Interrupt**

Syntax: [*label*] RETFIE

Operands: None

Operation: TOS → PC,
 1 → GIE

Status Affected: None

Description: Return from Interrupt. Stack is POPed and Top-of-Stack (TOS) is loaded in the PC. Interrupts are enabled by setting Global Interrupt Enable bit, GIE (INTCON<7>). This is a 2-cycle instruction.

Words: 1

Cycles: 2

Example: RETFIE

 After Interrupt

 PC = TOS

 GIE = 1

RETURN **Return from Subroutine**

Syntax: [*label*] RETURN

Operands: None

Operation: TOS → PC

Status Affected: None

Description: Return from subroutine. The stack is POPed and the top of the stack (TOS) is loaded into the program counter. This is a 2-cycle instruction.

RETLW **Return with literal in W**

Syntax: [*label*] RETLW k

Operands: $0 \leq k \leq 255$

Operation: k → (W);
 TOS → PC

Status Affected: None

Description: The W register is loaded with the 8-bit literal 'k'. The program counter is loaded from the top of the stack (the return address). This is a 2-cycle instruction.

Words: 1

Cycles: 2

Example: CALL TABLE;W contains table
 ;offset value

 • ;W now has table value

TABLE •

 •

 ADDWF PC ;W = offset

 RETLW k1 ;Begin table

 RETLW k2 ;

 •

 •

 •

 RETLW kn ; End of table

 Before Instruction

 W = 0x07

 After Instruction

 W = value of k8

RLF **Rotate Left f through Carry**

Syntax: [*label*] RLF f,d

Operands: $0 \leq f \leq 127$
 $d \in [0,1]$

Operation: See description below

Status Affected: C

Description: The contents of register 'f' are rotated one bit to the left through the Carry flag. If 'd' is '0', the result is placed in the W register. If 'd' is '1', the result is stored back in register 'f'.

Words: 1

Cycles: 1

Example: RLF REG1,0

 Before Instruction

 REG1 = 1110 0110

 C = 0

 After Instruction

 REG1 = 1110 0110

 W = 1100 1100

 C = 1

RRF Rotate Right f through Carry

Syntax: [*label*] RRF f,d

Operands: $0 \leq f \leq 127$
 $d \in [0,1]$

Operation: See description below

Status Affected: C

Description: The contents of register 'f' are rotated one bit to the right through the Carry flag. If 'd' is '0', the result is placed in the W register. If 'd' is '1', the result is placed back in register 'f'.

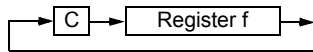

SLEEP Enter Sleep mode

Syntax: [*label*] SLEEP

Operands: None

Operation: 00h → WDT,
 0 → WDT prescaler,
 1 → \overline{TO} ,
 0 → \overline{PD}

Status Affected: \overline{TO} , \overline{PD}

Description: The power-down Status bit, \overline{PD} is cleared. Time-out Status bit, \overline{TO} is set. Watchdog Timer and its prescaler are cleared. The processor is put into Sleep mode with the oscillator stopped.

SUBLW Subtract W from literal

Syntax: [*label*] SUBLW k

Operands: $0 \leq k \leq 255$

Operation: $k - (W) \rightarrow (W)$

Status Affected: C, DC, Z

Description: The W register is subtracted (2's complement method) from the 8-bit literal 'k'. The result is placed in the W register.

C = 0	$W > k$
C = 1	$W \leq k$
DC = 0	$W\langle 3:0 \rangle > k\langle 3:0 \rangle$
DC = 1	$W\langle 3:0 \rangle \leq k\langle 3:0 \rangle$

SUBWF Subtract W from f

Syntax: [*label*] SUBWF f,d

Operands: $0 \leq f \leq 127$
 $d \in [0,1]$

Operation: $(f) - (W) \rightarrow (\text{destination})$

Status Affected: C, DC, Z

Description: Subtract (2's complement method) W register from register 'f'. If 'd' is '0', the result is stored in the W register. If 'd' is '1', the result is stored back in register 'f'.

C = 0	$W > f$
C = 1	$W \leq f$
DC = 0	$W\langle 3:0 \rangle > f\langle 3:0 \rangle$
DC = 1	$W\langle 3:0 \rangle \leq f\langle 3:0 \rangle$

SUBWFB Subtract W from f with Borrow

Syntax: SUBWFB f {,d}

Operands: $0 \leq f \leq 127$
 $d \in [0,1]$

Operation: $(f) - (W) - (\overline{B}) \rightarrow \text{dest}$

Status Affected: C, DC, Z

Description: Subtract W and the BORROW flag (CARRY) from register 'f' (2's complement method). If 'd' is '0', the result is stored in W. If 'd' is '1', the result is stored back in register 'f'.

PIC16LF1554/1559

SWAPF **Swap Nibbles in f**

Syntax: [*label*] SWAPF f,d

Operands: $0 \leq f \leq 127$
 $d \in [0,1]$

Operation: ($f<3:0>$) \rightarrow (destination $<7:4>$),
 ($f<7:4>$) \rightarrow (destination $<3:0>$)

Status Affected: None

Description: The upper and lower nibbles of register 'f' are exchanged. If 'd' is '0', the result is placed in the W register. If 'd' is '1', the result is placed in register 'f'.

TRIS **Load TRIS Register with W**

Syntax: [*label*] TRIS f

Operands: $5 \leq f \leq 7$

Operation: (W) \rightarrow TRIS register 'f'

Status Affected: None

Description: Move data from W register to TRIS register.
 When 'f' = 5, TRISA is loaded.
 When 'f' = 6, TRISB is loaded.
 When 'f' = 7, TRISC is loaded.

XORLW **Exclusive OR literal with W**

Syntax: [*label*] XORLW k

Operands: $0 \leq k \leq 255$

Operation: (W) .XOR. k \rightarrow (W)

Status Affected: Z

Description: The contents of the W register are XOR'ed with the 8-bit literal 'k'. The result is placed in the W register.

XORWF **Exclusive OR W with f**

Syntax: [*label*] XORWF f,d

Operands: $0 \leq f \leq 127$
 $d \in [0,1]$

Operation: (W) .XOR. (f) \rightarrow (destination)

Status Affected: Z

Description: Exclusive OR the contents of the W register with register 'f'. If 'd' is '0', the result is stored in the W register. If 'd' is '1', the result is stored back in register 'f'.

25.0 ELECTRICAL SPECIFICATIONS

25.1 Absolute Maximum Ratings^(†)

Ambient temperature under bias	-40°C to +125°C
Storage temperature	-65°C to +150°C
Voltage on pins with respect to V _{SS}	
on V _{DD} pin	-0.3V to +4.0V
on $\overline{\text{MCLR}}$ pin	-0.3V to +9.0V
on all other pins	-0.3V to (V _{DD} + 0.3V)
Total power dissipation ⁽¹⁾	800 mW
Maximum current	
out of V _{SS} pin, -40°C ≤ T _A ≤ +85°C for industrial	210 mA
out of V _{SS} pin, -40°C ≤ T _A ≤ +125°C for extended	95 mA
into V _{DD} pin, -40°C ≤ T _A ≤ +85°C for industrial	150 mA
into V _{DD} pin, -40°C ≤ T _A ≤ +125°C for extended	70 mA
Clamp current, I _K (V _{PIN} < 0 or V _{PIN} > V _{DD})	± 20 mA
Maximum output current	
sunk by any I/O pin	25 mA
sourced by any I/O pin	25 mA

Note 1: Power dissipation is calculated as follows: $P_{DIS} = V_{DD} \times \{I_{DD} - \sum I_{OH}\} + \sum \{(V_{DD} - V_{OH}) \times I_{OH}\} + \sum (V_{OL} \times I_{OL})$.

† NOTICE: Stresses above those listed under “Absolute Maximum Ratings” may cause permanent damage to the device. This is a stress rating only and functional operation of the device at those or any other conditions above those indicated in the operation listings of this specification is not implied. Exposure above maximum rating conditions for extended periods may affect device reliability.

25.2 Standard Operating Conditions

The standard operating conditions for any device are defined as:

Operating Voltage: $V_{DDMIN} \leq V_{DD} \leq V_{DDMAX}$

Operating Temperature: $T_{A_MIN} \leq T_A \leq T_{A_MAX}$

V_{DD} — Operating Supply Voltage⁽¹⁾

V _{DDMIN} (F _{osc} ≤ 16 MHz)	+1.8V
V _{DDMIN} (16 MHz < F _{osc} ≤ 32 MHz)	+2.5V
V _{DDMAX}	+3.6V

T_A — Operating Ambient Temperature Range

Industrial Temperature

T _{A_MIN}	-40°C
T _{A_MAX}	+85°C

Extended Temperature

T _{A_MIN}	-40°C
T _{A_MAX}	+125°C

Note 1: See Parameter [D001](#) in DC Characteristics: Supply Voltage.

PIC16LF1554/1559

FIGURE 25-1: PIC16LF1554/1559 VOLTAGE FREQUENCY GRAPH, $-40^{\circ}\text{C} \leq T_A \leq +125^{\circ}\text{C}$

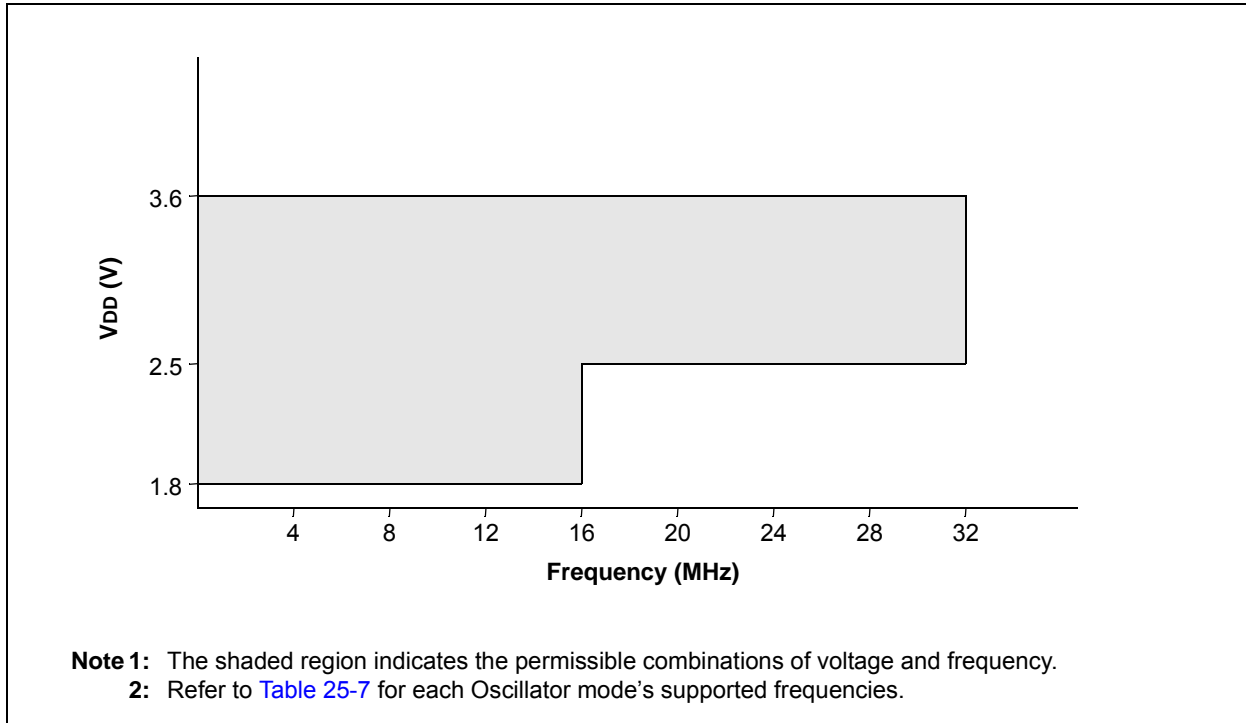

25.3 DC Characteristics

TABLE 25-1: SUPPLY VOLTAGE

PIC16LF1554/1559		Standard Operating Conditions (unless otherwise stated)					
		Operating temperature $-40^{\circ}\text{C} \leq T_A \leq +85^{\circ}\text{C}$ for industrial $-40^{\circ}\text{C} \leq T_A \leq +125^{\circ}\text{C}$ for extended					
Param. No.	Sym.	Characteristic	Min.	Typ.†	Max.	Units	Conditions
D001	VDD	Supply Voltage (VDDMIN, VDDMAX)					
			1.8	—	3.6	V	Fosc ≤ 16 MHz:
			2.5	—	3.6	V	Fosc ≤ 32 MHz
D002*	VDR	RAM Data Retention Voltage⁽¹⁾	1.5	—	—	V	Device in Sleep mode
D002A*	VPOR*	Power-on Reset Release Voltage	—	1.6	—	V	
D002B*	VPORR*	Power-on Reset Rearm Voltage	—	0.8	—	V	
D003	VADFVR	Fixed Voltage Reference Voltage for ADC, Initial Accuracy	-7	—	6	%	1.024V, VDD ≥ 2.5V, 85°C (Note 2)
			-8	—	6		1.024V, VDD ≥ 2.5V, 125°C (Note 2)
			-7	—	6		2.048V, VDD ≥ 2.5V, 85°C
			-8	—	6		2.048V, VDD ≥ 2.5V, 125°C
D003C*	TCVFVR	Temperature Coefficient, Fixed Voltage Reference	—	-130	—	ppm/°C	
D003D*	$\frac{\Delta V_{FVR}}{\Delta V_{IN}}$	Line Regulation, Fixed Voltage Reference	—	0.270	—	%/V	
D004*	SVDD	VDD Rise Rate to ensure internal Power-on Reset signal	0.05	—	—	V/ms	See Section 6.1 “Power-on Reset (POR)” for details.

* These parameters are characterized but not tested.

† Data in “Typ.” column is at 3.0V, 25°C unless otherwise stated. These parameters are for design guidance only and are not tested.

Note 1: This is the limit to which VDD can be lowered in Sleep mode without losing RAM data.

Note 2: For proper operation, the minimum value of the ADC positive voltage reference must be 1.8V or greater. When selecting the FVR or the VREF+ pin as the source of the ADC positive voltage reference, be aware that the voltage must be 1.8V or greater.

FIGURE 25-2: POR AND POR REARM WITH SLOW RISING VDD

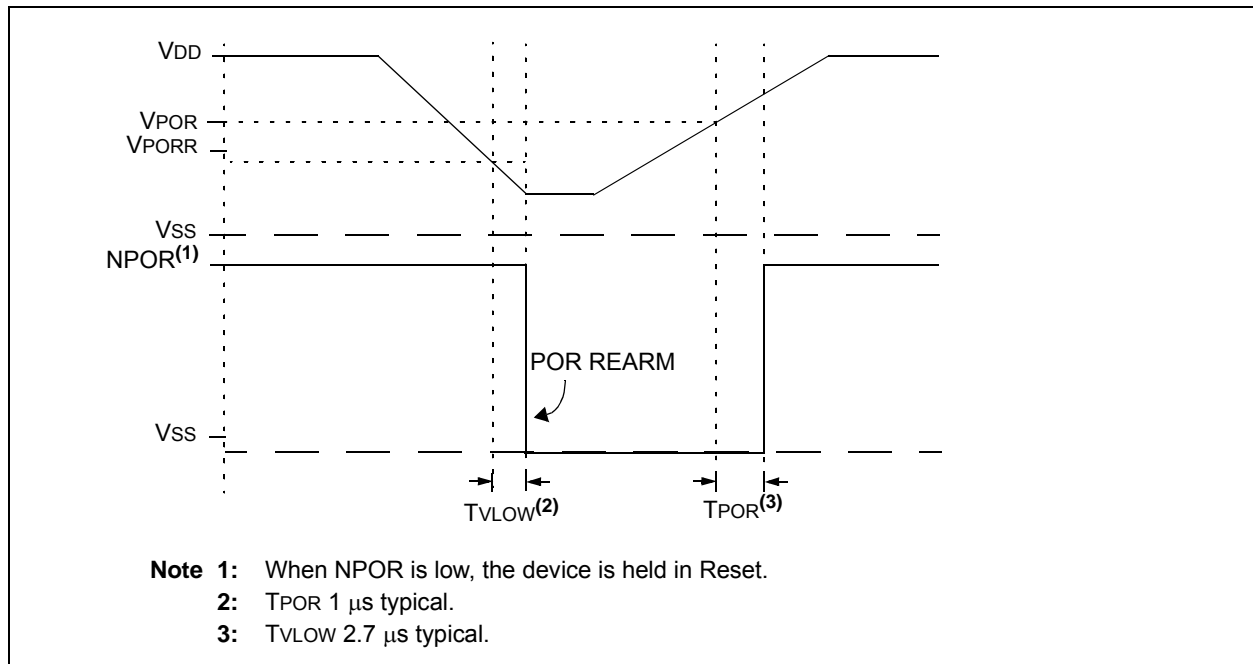

PIC16LF1554/1559

TABLE 25-2: SUPPLY CURRENT (IDD)

PIC16LF1554/1559		Standard Operating Conditions (unless otherwise stated) Operating temperature $-40^{\circ}\text{C} \leq T_A \leq +85^{\circ}\text{C}$ for industrial $-40^{\circ}\text{C} \leq T_A \leq +125^{\circ}\text{C}$ for extended					
Param. No.	Device Characteristics	Min.	Typ.†	Max.	Units	Conditions	
						VDD	Note
Supply Current (IDD)^(1, 2)							
D010		—	2.5	18	μA	1.8	Fosc = 31 kHz
		—	4	20	μA	3.0	LFINTOSC mode
D011		—	0.35	0.70	mA	1.8	Fosc = 8 MHz
		—	0.5	1.10	mA	3.0	HFINTOSC mode
D012		—	0.5	1.2	mA	1.8	Fosc = 16 MHz
		—	0.75	1.75	mA	3.0	HFINTOSC mode
D013		—	1.4	3.5	mA	3.0	Fosc = 32 MHz HFINTOSC mode with PLL
D014		—	3	17	μA	1.8	Fosc = 32 kHz
		—	5	20	μA	3.0	ECL mode
D015		—	11	40	μA	1.8	Fosc = 500 kHz
		—	16	60	μA	3.0	ECL mode
D016		—	23	65	μA	1.8	Fosc = 1 MHz
		—	36	100	μA	3.0	ECM mode
D017		—	75	250	μA	1.8	Fosc = 4 MHz
		—	120	430	μA	3.0	ECM mode
D018		—	0.65	1.5	mA	3.0	Fosc = 20 MHz ECH mode

† Data in "Typ." column is at 25°C unless otherwise stated. These parameters are for design guidance only and are not tested.

- Note 1:** The test conditions for all IDD measurements in active operation mode are: CLKIN = external square wave, from rail-to-rail; all I/O pins tri-stated, pulled to VDD; MCLR = VDD; WDT disabled.
- 2:** The supply current is mainly a function of the operating voltage and frequency. Other factors, such as I/O pin loading and switching rate, oscillator type, internal code execution pattern and temperature, also have an impact on the current consumption.

TABLE 25-3: POWER-DOWN CURRENTS (IPD)

PIC16LF1554/1559		Standard Operating Conditions (unless otherwise stated)						
		Operating temperature $-40^{\circ}\text{C} \leq T_A \leq +85^{\circ}\text{C}$ for industrial $-40^{\circ}\text{C} \leq T_A \leq +125^{\circ}\text{C}$ for extended						
Param. No.	Device Characteristics	Min.	Typ.†	Max. +85°C	Max. +125°C	Units	Conditions	
							VDD	Note
Power-down Base Current (IPD)⁽²⁾								
D020		—	0.02	1.0	8	μA	1.8	WDT, BOR, FVR, and T1OSC disabled, all Peripherals Inactive
		—	0.03	2	9	μA	3.0	
D021		—	0.24	2	9	μA	1.8	LPWDT Current (Note 1)
		—	0.37	3	10	μA	3.0	
D022		—	13	28	30	μA	1.8	FVR current (Note 1)
		—	22	30	33	μA	3.0	
D023		—	6.5	17	20	μA	3.0	BOR Current (Note 1)
D024		—	0.1	4	10	μA	3.0	LPBOR Current
D025		—	0.03	3.5	9	μA	1.8	ADC Current (Note 1, Note 3), no conversion in progress
		—	0.04	4.0	10	μA	3.0	
D026*		—	250	—	—	μA	1.8	ADC Current (Note 1, Note 3), conversion in progress
		—	250	—	—	μA	3.0	

* These parameters are characterized but not tested.

† Data in "Typ." column is at 25°C unless otherwise stated. These parameters are for design guidance only and are not tested.

- Note 1:** The peripheral current is the sum of the base IDD or IPD and the additional current consumed when this peripheral is enabled. The peripheral Δ current can be determined by subtracting the base IDD or IPD current from this limit. Max values should be used when calculating total current consumption.
- 2:** The power-down current in Sleep mode does not depend on the oscillator type. Power-down current is measured with the part in Sleep mode, with all I/O pins in high-impedance state and tied to VDD.
- 3:** ADC oscillator source is FRC.

PIC16LF1554/1559

TABLE 25-4: I/O PORTS

DC CHARACTERISTICS			Standard Operating Conditions (unless otherwise stated) Operating temperature $-40^{\circ}\text{C} \leq T_A \leq +85^{\circ}\text{C}$ for industrial $-40^{\circ}\text{C} \leq T_A \leq +125^{\circ}\text{C}$ for extended					
Param. No.	Sym.	Characteristic	Min.	Typ.†	Max.	Units	Conditions	
D030 D031 D032 D040 D041 D042	VIL	Input Low Voltage						
		I/O PORT:						
		with TTL buffer	—	—	0.15 VDD	V	$1.8\text{V} \leq V_{DD} \leq 3.6\text{V}$	
			with Schmitt Trigger buffer	—	—	0.2 VDD	V	$2.0\text{V} \leq V_{DD} \leq 3.6\text{V}$
			MCLR	—	—	0.2 VDD	V	
		VIH	Input High Voltage					
	I/O ports:			—	—			
	with TTL buffer		0.25 VDD + 0.8	—	—	V	$1.8\text{V} \leq V_{DD} \leq 3.6\text{V}$	
	with Schmitt Trigger buffer		0.8 VDD	—	—	V	$2.0\text{V} \leq V_{DD} \leq 3.6\text{V}$	
		MCLR	0.8 VDD	—	—	V		
D060 D061	IIL	Input Leakage Current⁽¹⁾						
		I/O ports	—	± 5	± 125	nA	$V_{SS} \leq V_{PIN} \leq V_{DD}$, Pin at high-impedance at 85°C	
		MCLR ⁽²⁾	—	± 5 ± 50	± 1000 ± 200	nA nA	$V_{SS} \leq V_{PIN} \leq V_{DD}$ at 85°C	
D070*	IPUR	Weak Pull-up Current						
			25	100	200	μA	$V_{DD} = 3.3\text{V}$, $V_{PIN} = V_{SS}$	
D080	VOL	Output Low Voltage⁽³⁾						
		I/O ports	—	—	0.6	V	$I_{OL} = 6\text{mA}$, $V_{DD} = 3.3\text{V}$ $I_{OL} = 1.8\text{mA}$, $V_{DD} = 1.8\text{V}$	
D090	VOH	Output High Voltage⁽³⁾						
		I/O ports	$V_{DD} - 0.7$	—	—	V	$I_{OH} = 3\text{mA}$, $V_{DD} = 3.3\text{V}$ $I_{OH} = 1\text{mA}$, $V_{DD} = 1.8\text{V}$	
D101A*	Cio	Capacitive Loading Specs on Output Pins						
		All I/O pins	—	—	50	pF		

* These parameters are characterized but not tested.

† Data in "Typ." column is at 3.0V, 25°C unless otherwise stated. These parameters are for design guidance only and are not tested.

Note 1: Negative current is defined as current sourced by the pin.

Note 2: The leakage current on the MCLR pin is strongly dependent on the applied voltage level. The specified levels represent normal operating conditions. Higher leakage current may be measured at different input voltages.

Note 3: Including OSC2 in CLKOUT mode.

TABLE 25-5: MEMORY PROGRAMMING SPECIFICATIONS

DC CHARACTERISTICS			Standard Operating Conditions (unless otherwise stated) Operating temperature $-40^{\circ}\text{C} \leq T_A \leq +125^{\circ}\text{C}$				
Param. No.	Sym.	Characteristic	Min.	Typ.†	Max.	Units	Conditions
Program Memory Programming Specifications							
D110	V _{IHH}	Voltage on $\overline{\text{MCLR}}/\text{VPP}$ pin	8.0	—	9.0	V	(Note 2)
D111	I _{DDP}	Supply Current during Programming	—	—	10	mA	
D112	V _{BE}	V _{DD} for Bulk Erase	2.7	—	V _{DDMAX}	V	
D113	V _{PEW}	V _{DD} for Write or Row Erase	V _{DDMIN}	—	V _{DDMAX}	V	
D114	I _{PPGM}	Current on $\overline{\text{MCLR}}/\text{VPP}$ during Erase/Write	—	—	1.0	mA	
D115	I _{DDPGM}	Current on V _{DD} during Erase/Write	—	—	5.0	mA	
D121	EP	Program Flash Memory Cell Endurance	10K	—	—	E/W	-40°C to +85°C (Note 1) Provided no other specifications are violated 0°C to +60°C, Lower byte, Last 128 Addresses in Flash Memory
D122	V _{PRW}	V _{DD} for Read/Write	V _{DDMIN}	—	V _{DDMAX}	V	
D123	T _{IW}	Self-timed Write Cycle Time	—	2	2.5	ms	
D124	T _{RETD}	Characteristic Retention	—	40	—	Year	
D125	EHEFC	High-Endurance Flash Cell	100K	—	—	E/W	

† Data in "Typ." column is at 3.0V, 25°C unless otherwise stated. These parameters are for design guidance only and are not tested.

Note 1: Self-write and Block Erase.

2: Required only if single-supply programming is disabled.

PIC16LF1554/1559

TABLE 25-6: THERMAL CHARACTERISTICS

Standard Operating Conditions (unless otherwise stated) Operating temperature $-40^{\circ}\text{C} \leq T_A \leq +125^{\circ}\text{C}$					
Param. No.	Sym.	Characteristic	Typ.	Units	Conditions
TH01	θ_{JA}	Thermal Resistance Junction to Ambient	70.0	$^{\circ}\text{C}/\text{W}$	14-pin PDIP package
			95.3	$^{\circ}\text{C}/\text{W}$	14-pin SOIC package
			100.0	$^{\circ}\text{C}/\text{W}$	14-pin TSSOP package
			45.7	$^{\circ}\text{C}/\text{W}$	16-pin QFN (4x4x0.9 mm) package
			62.2	$^{\circ}\text{C}/\text{W}$	20-pin PDIP package
			87.3	$^{\circ}\text{C}/\text{W}$	20-pin SSOP package
			43.0	$^{\circ}\text{C}/\text{W}$	20-pin QFN package
TH02	θ_{JC}	Thermal Resistance Junction to Case	32.8	$^{\circ}\text{C}/\text{W}$	14-pin PDIP package
			31.0	$^{\circ}\text{C}/\text{W}$	14-pin SOIC package
			24.4	$^{\circ}\text{C}/\text{W}$	14-pin TSSOP package
			6.3	$^{\circ}\text{C}/\text{W}$	16-pin QFN (4x4x0.9 mm) package
			27.5	$^{\circ}\text{C}/\text{W}$	20-pin PDIP package
			31.1	$^{\circ}\text{C}/\text{W}$	20-pin SSOP package
			5.3	$^{\circ}\text{C}/\text{W}$	20-pin QFN package
TH03	T_{JMAX}	Maximum Junction Temperature	150	$^{\circ}\text{C}$	
TH04	PD	Power Dissipation	—	W	$PD = P_{INTERNAL} + P_{I/O}$
TH05	$P_{INTERNAL}$	Internal Power Dissipation	—	W	$P_{INTERNAL} = I_{DD} \times V_{DD}^{(1)}$
TH06	$P_{I/O}$	I/O Power Dissipation	—	W	$P_{I/O} = \sum (I_{OL} \times V_{OL}) + \sum (I_{OH} \times (V_{DD} - V_{OH}))$
TH07	P_{DER}	Derated Power	—	W	$P_{DER} = P_{D_{MAX}} (T_J - T_A) / \theta_{JA}^{(2)}$

Note 1: I_{DD} is current to run the chip alone without driving any load on the output pins.

2: T_A = Ambient Temperature; T_J = Junction Temperature.

25.4 AC Characteristics

Timing Parameter Symbolology has been created with one of the following formats:

1. TppS2ppS
2. TppS

T			
F	Frequency	T	Time

Lowercase letters (pp) and their meanings:

pp			
cc	CCP1	osc	CLKIN
ck	CLKOUT	rd	\overline{RD}
cs	\overline{CS}	rw	\overline{RD} or \overline{WR}
di	SDIx	sc	SCKx
do	SDO	ss	\overline{SS}
dt	Data in	t0	T0CKI
io	I/O PORT	t1	T1CKI
mc	\overline{MCLR}	wr	\overline{WR}

Uppercase letters and their meanings:

S			
F	Fall	P	Period
H	High	R	Rise
I	Invalid (High-impedance)	V	Valid
L	Low	Z	High-impedance

FIGURE 25-3: LOAD CONDITIONS

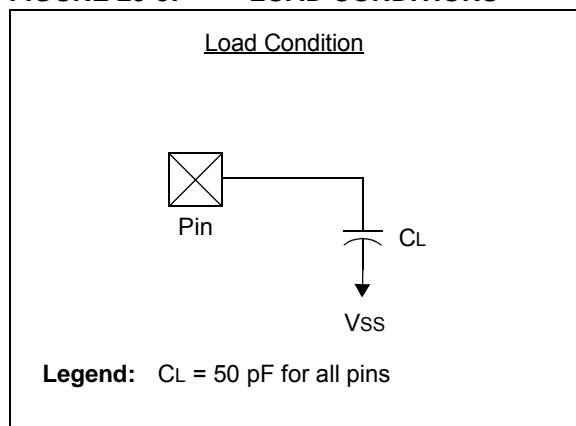
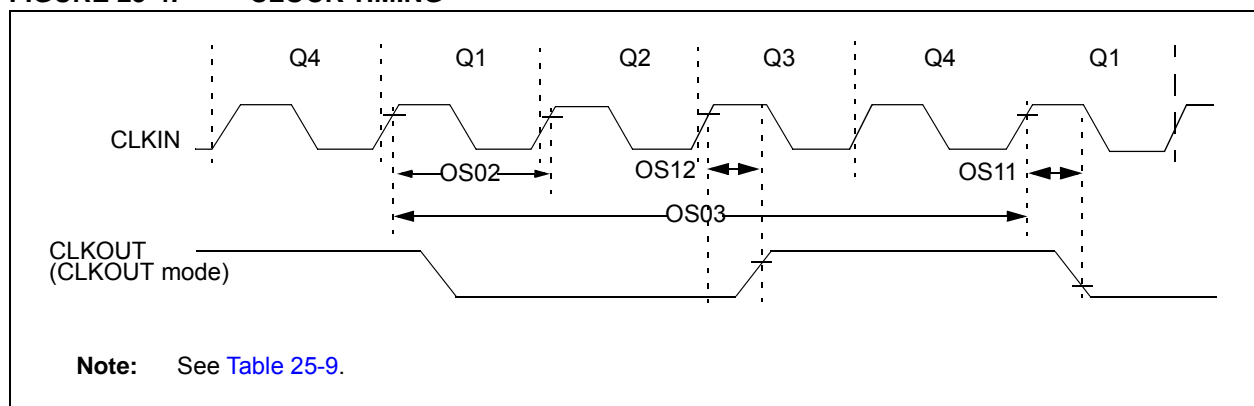

FIGURE 25-4: CLOCK TIMING



PIC16LF1554/1559

TABLE 25-7: CLOCK OSCILLATOR TIMING REQUIREMENTS

Standard Operating Conditions (unless otherwise stated)							
Operating temperature $-40^{\circ}\text{C} \leq T_A \leq +125^{\circ}\text{C}$							
Param. No.	Sym.	Characteristic	Min.	Typ.†	Max.	Units	Conditions
OS01	FOSC	External CLKIN Frequency ⁽¹⁾	DC	—	0.5	MHz	EC Oscillator mode (low)
			DC	—	4	MHz	EC Oscillator mode (medium)
			DC	—	20	MHz	EC Oscillator mode (high)
OS02	TOSC	External CLKIN Period ⁽¹⁾	50	—	∞	ns	EC mode
OS03	Tcy	Instruction Cycle Time ⁽¹⁾	200	—	DC	ns	Tcy = FOSC/4

* These parameters are characterized but not tested.

† Data in "Typ." column is at 3.0V, 25°C unless otherwise stated. These parameters are for design guidance only and are not tested.

Note 1: Instruction cycle period (Tcy) equals four times the input oscillator time base period. All specified values are based on characterization data for that particular oscillator type under standard operating conditions with the device executing code. Exceeding these specified limits may result in an unstable oscillator operation and/or higher than expected current consumption. All devices are tested to operate at "min" values with an external clock applied to CLKIN pin. When an external clock input is used, the "max" cycle time limit is "DC" (no clock) for all devices.

TABLE 25-8: OSCILLATOR PARAMETERS

Standard Operating Conditions (unless otherwise stated)							
Operating Temperature $-40^{\circ}\text{C} \leq T_A \leq +125^{\circ}\text{C}$							
Param. No.	Sym.	Characteristic	Min.	Typ.†	Max.	Units	Conditions
OS08	HFOSC	Internal Calibrated HFINTOSC Frequency ⁽¹⁾	—	16.0	—	MHz	$0^{\circ}\text{C} \leq T_A \leq +85^{\circ}\text{C}$
OS08A	HFTOL	Frequency Tolerance	—	± 3	—	%	25°C , 16 MHz
			—	± 6	—	%	$0^{\circ}\text{C} \leq T_A \leq +85^{\circ}\text{C}$, 16 MHz
OS09	LFOSC	Internal LFINTOSC Frequency	—	31	—	kHz	$-40^{\circ}\text{C} \leq T_A \leq +125^{\circ}\text{C}$
OS10*	TIOSC ST	HFINTOSC Wake-up from Sleep Start-up Time	—	5	8	μs	

* These parameters are characterized but not tested.

† Data in "Typ." column is at 3.0V, 25°C unless otherwise stated. These parameters are for design guidance only and are not tested.

Note 1: To ensure these oscillator frequency tolerances, VDD and VSS must be capacitively decoupled as close to the device as possible. 0.1 μF and 0.01 μF values in parallel are recommended.

FIGURE 25-5: CLKOUT AND I/O TIMING

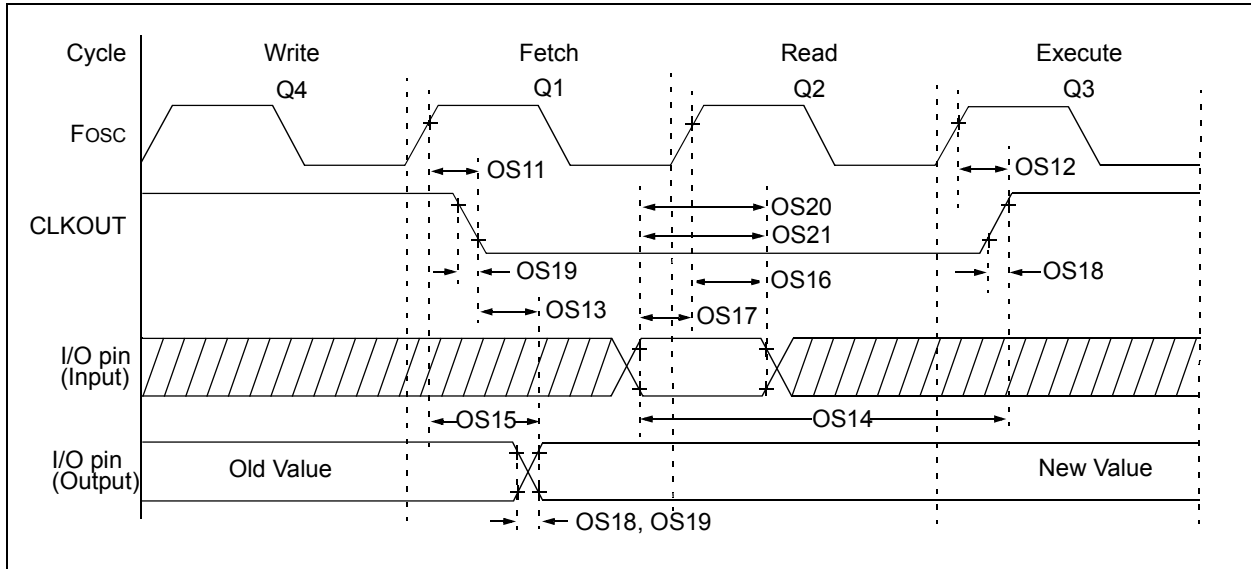

TABLE 25-9: CLKOUT AND I/O TIMING PARAMETERS

Standard Operating Conditions (unless otherwise stated) Operating Temperature $-40^{\circ}\text{C} \leq T_A \leq +125^{\circ}\text{C}$							
Param. No.	Sym.	Characteristic	Min.	Typ.†	Max.	Units	Conditions
OS11	TosH2ckL	Fosc \uparrow to CLKOUT \downarrow (1)	—	—	70	ns	VDD = 3.3-3.6V
OS12	TosH2ckH	Fosc \uparrow to CLKOUT \uparrow (1)	—	—	72	ns	VDD = 3.3-3.6V
OS13	TckL2ioV	CLKOUT \downarrow to Port out valid(1)	—	—	20	ns	
OS14	TioV2ckH	Port input valid before CLKOUT \uparrow (1)	Tosc + 200 ns	—	—	ns	
OS15	TosH2ioV	Fosc \uparrow (Q1 cycle) to Port out valid	—	50	70*	ns	VDD = 3.3-3.6V
OS16	TosH2ioI	Fosc \uparrow (Q2 cycle) to Port input invalid (I/O in hold time)	50	—	—	ns	VDD = 3.3-3.6V
OS17	TioV2osH	Port input valid to Fosc \uparrow (Q2 cycle) (I/O in setup time)	20	—	—	ns	
OS18*	TioR	Port output rise time	—	15	32	ns	VDD = 2.0V
OS19*	TioF	Port output fall time	—	28	55	ns	VDD = 2.0V
OS20*	Tinp	INT pin input high or low time	25	—	—	ns	
OS21*	Tioc	Interrupt-on-change new input level time	25	—	—	ns	

* These parameters are characterized but not tested.

† Data in "Typ." column is at 3.0V, 25°C unless otherwise stated.

Note 1: Measurements are taken in EC mode where CLKOUT output is 4 x TOSC.

PIC16LF1554/1559

FIGURE 25-6: RESET, WATCHDOG TIMER AND POWER-UP TIMER TIMING

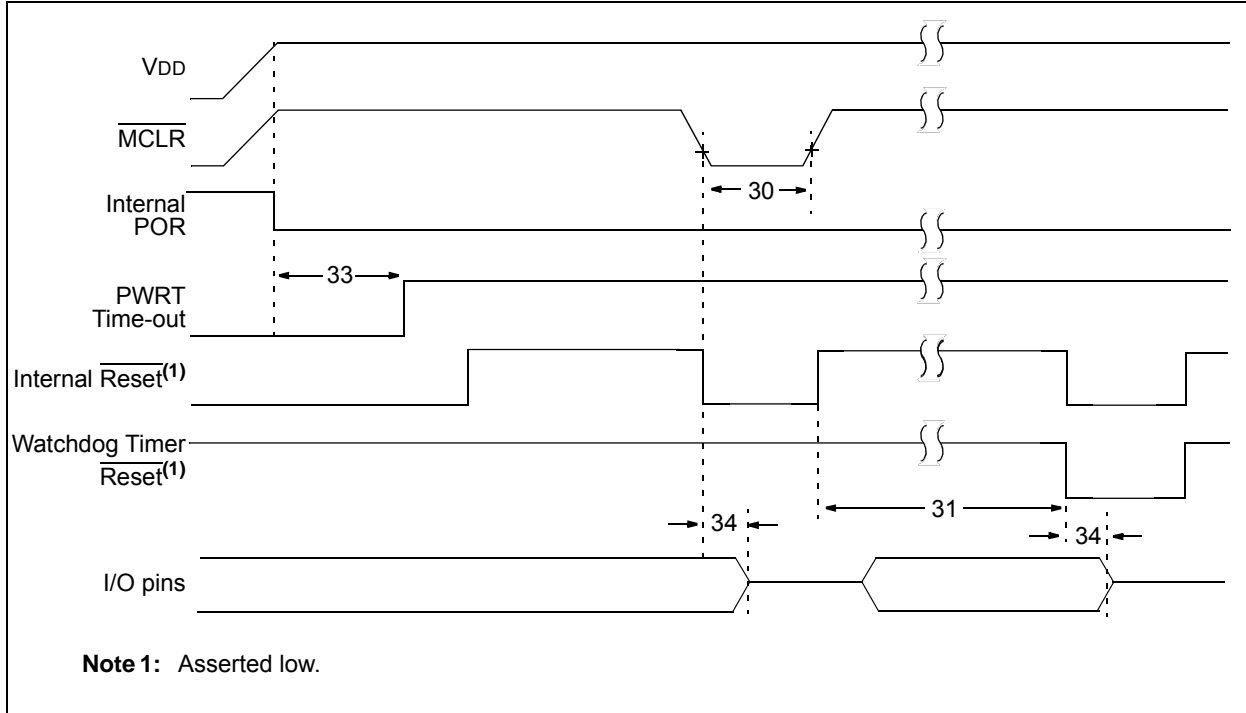

FIGURE 25-7: BROWN-OUT RESET TIMING AND CHARACTERISTICS

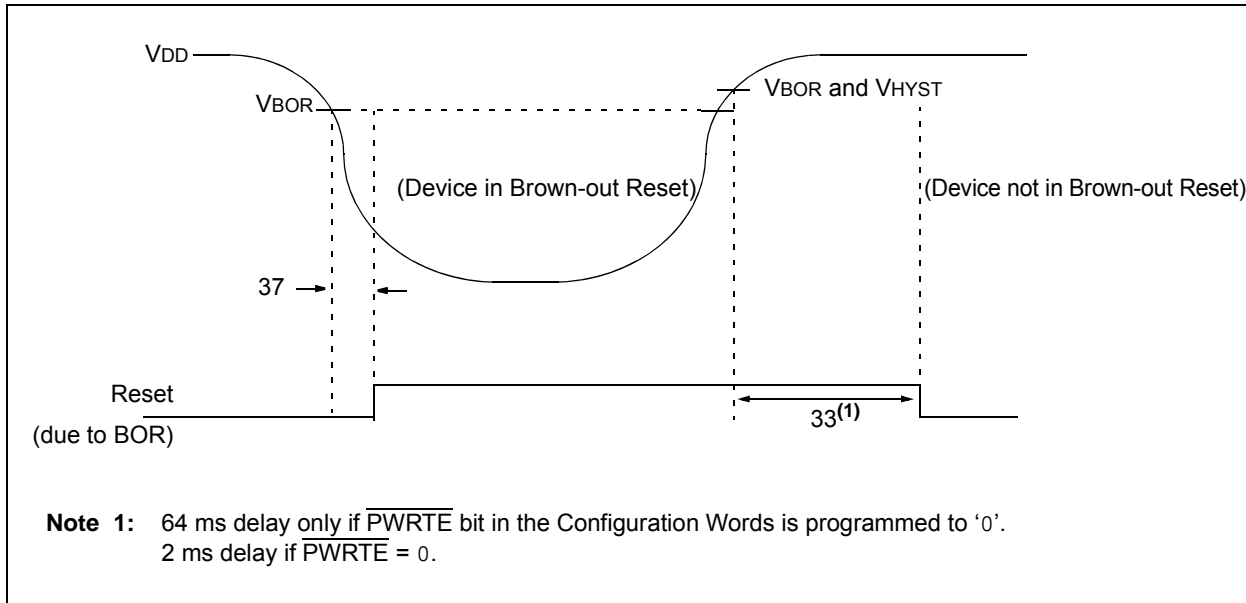

TABLE 25-10: RESET, WATCHDOG TIMER, POWER-UP TIMER AND BROWN-OUT RESET PARAMETERS

Standard Operating Conditions (unless otherwise stated) Operating Temperature $-40^{\circ}\text{C} \leq T_A \leq +125^{\circ}\text{C}$							
Param. No.	Sym.	Characteristic	Min.	Typ.†	Max.	Units	Conditions
30	TMCL	$\overline{\text{MCLR}}$ Pulse Width (low)	2	—	—	μs	-40°C to $+85^{\circ}\text{C}$
			5	—	—	μs	$+85^{\circ}\text{C}$ to $+125^{\circ}\text{C}$
31	TWDTLP	Low-Power Watchdog Timer Time-out Period	10	16	27	ms	$V_{\text{DD}} = 3.3\text{V}-3.6\text{V}$, 1:16 Prescaler used
33*	TPWRT	Power-up Timer Period, PWRTE = 0	40	65	140	ms	
34*	TIOZ	I/O high-impedance from $\overline{\text{MCLR}}$ Low or Watchdog Timer Reset	—	—	2.0	μs	
35	VBOR	Brown-out Reset Voltage ⁽¹⁾	2.55	2.70	2.85	V	BORV = 0
			1.80	1.90	2.05	V	BORV = 1
36*	VHYST	Brown-out Reset Hysteresis	0	25	50	mV	-40°C to $+85^{\circ}\text{C}$
37*	TBORDC	Brown-out Reset DC Response Time	1	3	5	μs	$V_{\text{DD}} \leq V_{\text{BOR}}$

* These parameters are characterized but not tested.

† Data in "Typ." column is at 3.0V, 25°C unless otherwise stated. These parameters are for design guidance only and are not tested.

Note 1: To ensure these voltage tolerances, V_{DD} and V_{SS} must be capacitively decoupled as close to the device as possible. 0.1 μF and 0.01 μF values in parallel are recommended.

FIGURE 25-8: TIMER0 EXTERNAL CLOCK TIMINGS

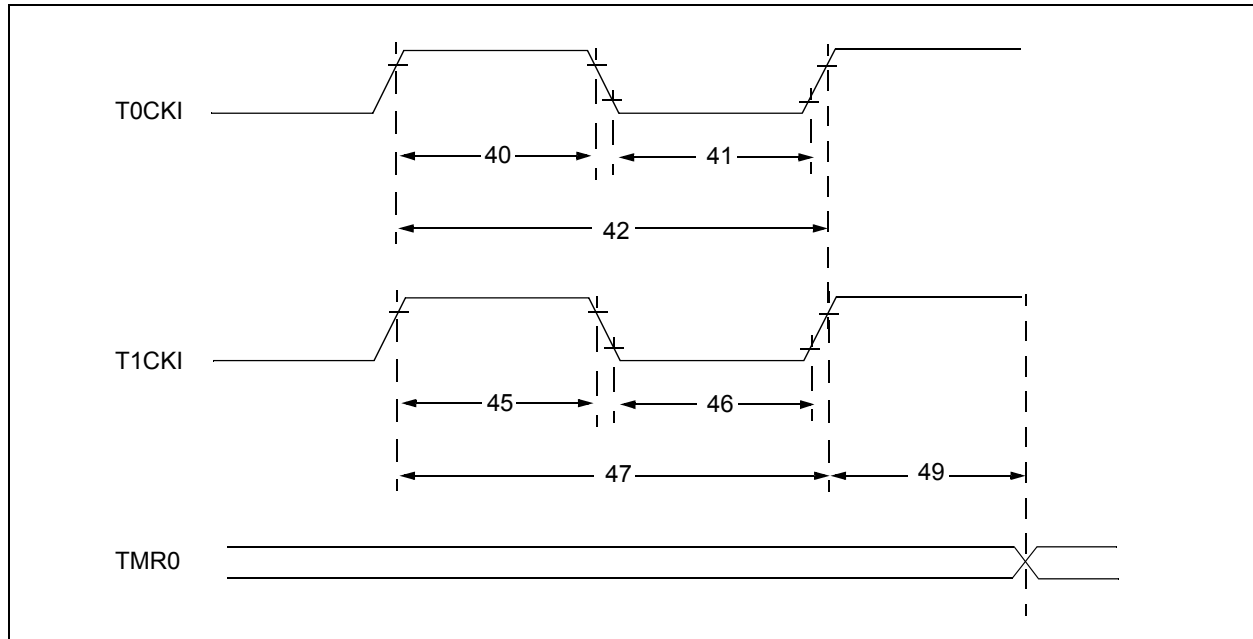

PIC16LF1554/1559

TABLE 25-11: TIMER0 AND TIMER1 EXTERNAL CLOCK REQUIREMENTS

Standard Operating Conditions (unless otherwise stated)								
Param. No.	Sym.	Characteristic		Min.	Typ.†	Max.	Units	Conditions
40*	T _{T0H}	T0CKI High Pulse Width	No Prescaler	0.5 T _{CY} + 20	—	—	ns	
			With Prescaler	10	—	—	ns	
41*	T _{T0L}	T0CKI Low Pulse Width	No Prescaler	0.5 T _{CY} + 20	—	—	ns	
			With Prescaler	10	—	—	ns	
42*	T _{T0P}	T0CKI Period		Greater of: 20 or $\frac{T_{CY} + 40}{N}$	—	—	ns	N = prescale value
45*	T _{T1H}	T1CKI High Time	Synchronous, No Prescaler	0.5 T _{CY} + 20	—	—	ns	
			Synchronous, with Prescaler	15	—	—	ns	
			Asynchronous	30	—	—	ns	
46*	T _{T1L}	T1CKI Low Time	Synchronous, No Prescaler	0.5 T _{CY} + 20	—	—	ns	
			Synchronous, with Prescaler	15	—	—	ns	
			Asynchronous	30	—	—	ns	
47*	T _{T1P}	T1CKI Input Period	Synchronous	Greater of: 30 or $\frac{T_{CY} + 40}{N}$	—	—	ns	N = prescale value
			Asynchronous	60	—	—	ns	
48*	TCKEZTMR1	Delay from External Clock Edge to Timer Increment		2 T _{osc}	—	7 T _{osc}	—	Timers in Sync mode

* These parameters are characterized but not tested.

† Data in "Typ." column is at 3.0V, 25°C unless otherwise stated. These parameters are for design guidance only and are not tested.

TABLE 25-12: PIC16LF1554/1559 ANALOG-TO-DIGITAL CONVERTER (ADC) CHARACTERISTICS^(1,2,3)

Standard Operating Conditions (unless otherwise stated)							
Operating temperature Tested at 25°C							
Param. No.	Sym.	Characteristic	Min.	Typ.†	Max.	Units	Conditions
AD01	NR	Resolution	—	—	10	bit	
AD02	EIL	Integral Error	—	±0.5	±1	LSb	-40°C to +85°C, ΔV _{REF} ≥ 2.0V
AD03	EDL	Differential Error	—	±0.4	±1	LSb	-40°C to +85°C, ΔV _{REF} ≥ 2.0V
AD04	E _{OFF}	Offset Error	—	0.4	±2	LSb	-40°C to +85°C, ΔV _{REF} ≥ 2.0V
AD05	E _{GN}	Gain Error	—	0.3	±2	LSb	-40°C to +85°C, ΔV _{REF} ≥ 2.0V
AD06	V _{REF}	Reference Voltage Range (V _{REFH} – V _{REFL})	1.8	—	—	V	Absolute Minimum (Note 4) Minimum for 1LSb Accuracy
			2.0	—	—	V	
AD07	V _{AIN}	Full-Scale Range	V _{SS}	—	V _{REF}	V	
AD08	Z _{AIN}	Recommended Impedance of Analog Voltage Source	—	—	3	kΩ	Can go higher if external 0.01μF capacitor is present on input pin.

* These parameters are characterized but not tested.

† Data in "Typ." column is at 3.0V, 25°C unless otherwise stated. These parameters are for design guidance only and are not tested.

Note 1: Total Absolute Error includes integral, differential, offset and gain errors.

2: The ADC conversion result never decreases with an increase in the input voltage and has no missing codes.

3: When ADC is off, it will not consume any current other than leakage current. The power-down current specification includes any such leakage from the ADC module.

4: ADC V_{REF} is selected by ADPREF<1:0> bits.

TABLE 25-13: PIC16LF1554/1559 ADC CONVERSION REQUIREMENTS

Standard Operating Conditions (unless otherwise stated) Operating temperature $-40^{\circ}\text{C} \leq T_A \leq +125^{\circ}\text{C}$							
Param. No.	Sym.	Characteristic	Min.	Typ.†	Max.	Units	Conditions
AD130*	TAD	ADC Clock Period	0.7	—	25	μs	Tosc-based, -40°C to $+85^{\circ}\text{C}$
			0.7	—	8	μs	Tosc-based, $+85^{\circ}\text{C}$ to $+125^{\circ}\text{C}$
		ADC Internal FRC Oscillator Period	1.0	1.6	6.0	μs	ADCS<1:0> = 11 (ADFRC mode)
AD131	TcNV	Conversion Time (not including Acquisition Time) ⁽¹⁾	—	11	—	TAD	Set GO/DONEx bit to conversion complete
AD132*	TACQ	Acquisition Time	—	5.0	—	μs	

* These parameters are characterized but not tested.

† Data in "Typ." column is at 3.0V, 25°C unless otherwise stated. These parameters are for design guidance only and are not tested.

Note 1: The ADRES register may be read on the following T_{cy} cycle.

FIGURE 25-9: PIC16LF1554/1559 ADC CONVERSION TIMING (NORMAL MODE)

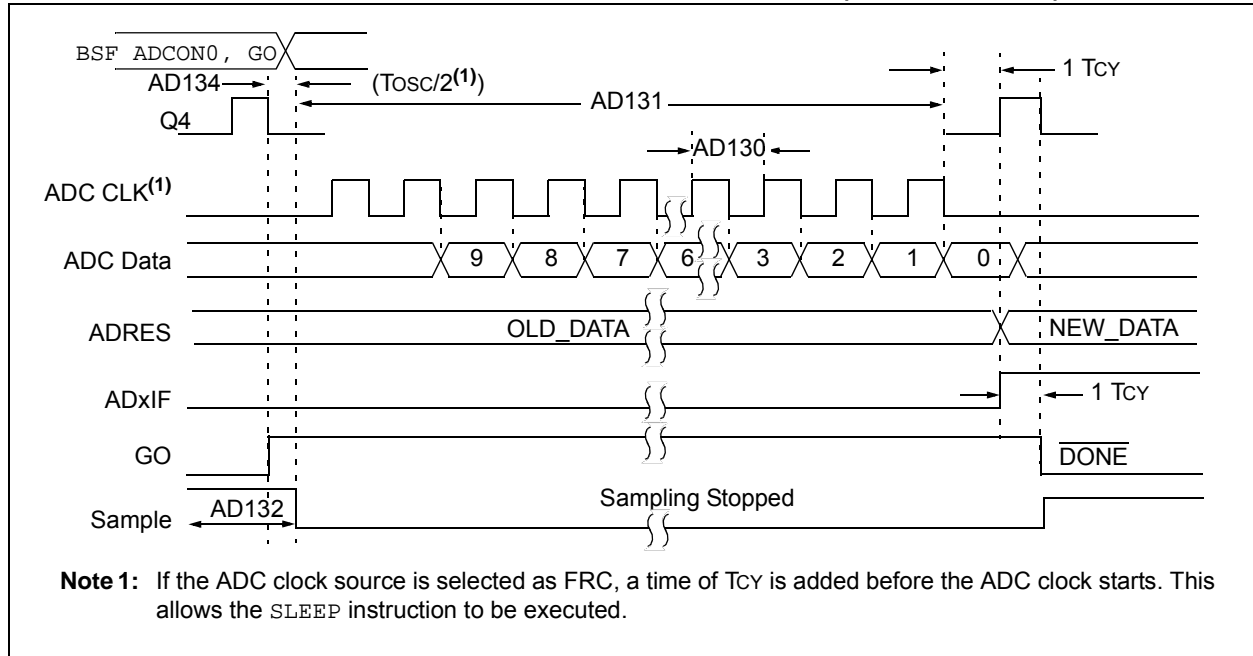

Note 1: If the ADC clock source is selected as FRC, a time of T_{cy} is added before the ADC clock starts. This allows the SLEEP instruction to be executed.

PIC16LF1554/1559

FIGURE 25-10: PIC16LF1554/1559 ADC CONVERSION TIMING (SLEEP MODE)

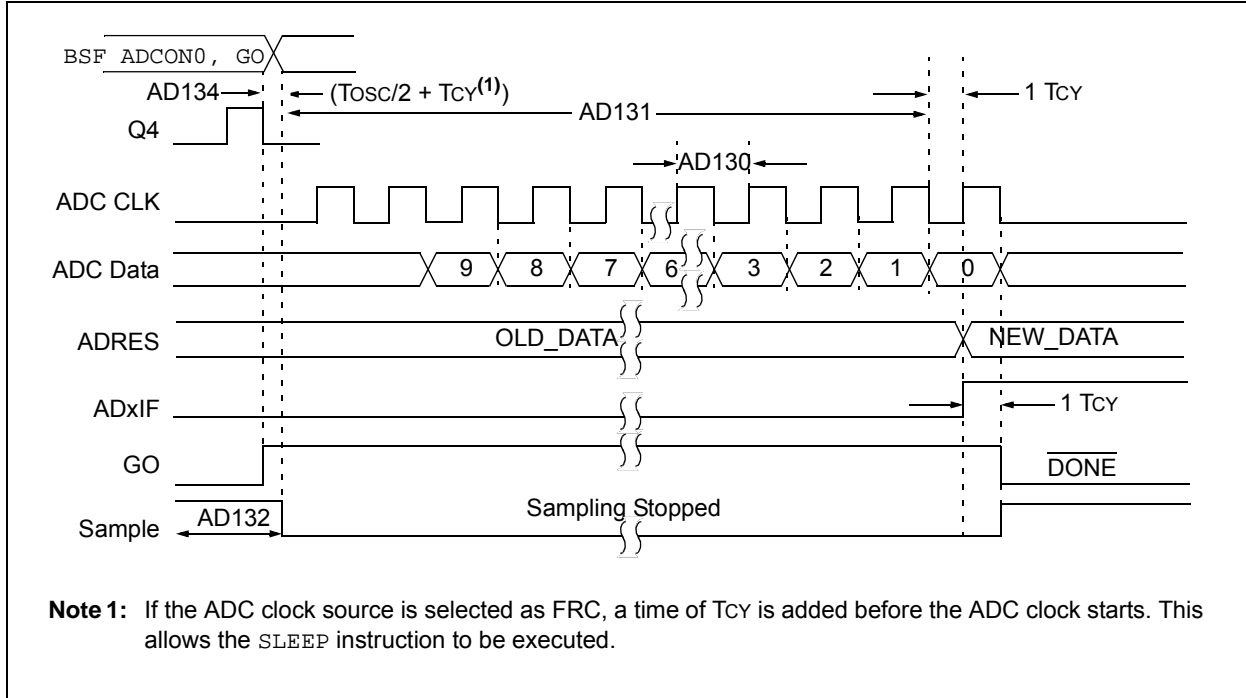

FIGURE 25-11: USART SYNCHRONOUS TRANSMISSION (MASTER/SLAVE) TIMING

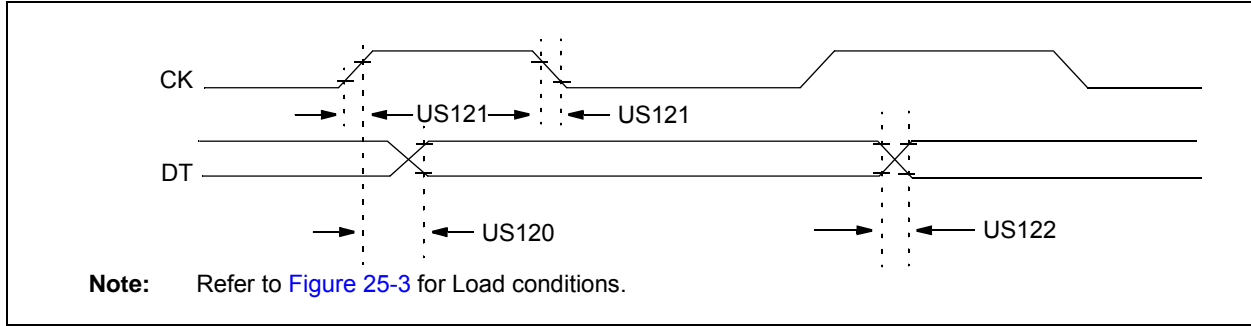

TABLE 25-14: USART SYNCHRONOUS TRANSMISSION REQUIREMENTS

Standard Operating Conditions (unless otherwise stated)						
Param. No.	Symbol	Characteristic	Min.	Max.	Units	Conditions
US120	TckH2DTV	SYNC XMIT (Master and Slave) Clock high to data-out valid	—	80	ns	$3.0V \leq V_{DD} \leq 3.3V$
			—	100	ns	$1.8V \leq V_{DD} \leq 3.3V$
US121	TCKRF	Clock out rise time and fall time (Master mode)	—	45	ns	$3.0V \leq V_{DD} \leq 3.3V$
			—	50	ns	$1.8V \leq V_{DD} \leq 3.3V$
US122	TDTRF	Data-out rise time and fall time	—	45	ns	$3.0V \leq V_{DD} \leq 3.3V$
			—	50	ns	$1.8V \leq V_{DD} \leq 3.3V$

FIGURE 25-12: USART SYNCHRONOUS RECEIVE (MASTER/SLAVE) TIMING

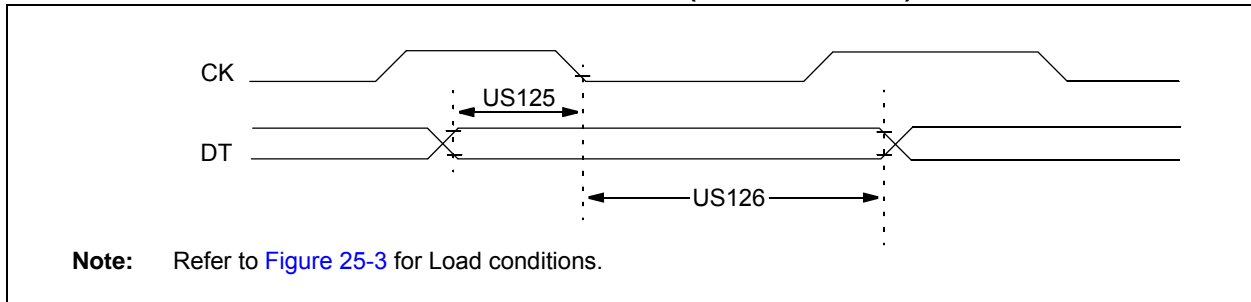

TABLE 25-15: USART SYNCHRONOUS RECEIVE REQUIREMENTS

Standard Operating Conditions (unless otherwise stated)						
Param. No.	Symbol	Characteristic	Min.	Max.	Units	Conditions
US125	TDTV2CKL	SYNC RCV (Master and Slave) Data-hold before CK ↓ (DT hold time)	10	—	ns	
US126	TCKL2DTL	Data-hold after CK ↓ (DT hold time)	15	—	ns	

PIC16LF1554/1559

FIGURE 25-13: SPI MASTER MODE TIMING (CKE = 0, SMP = 0)

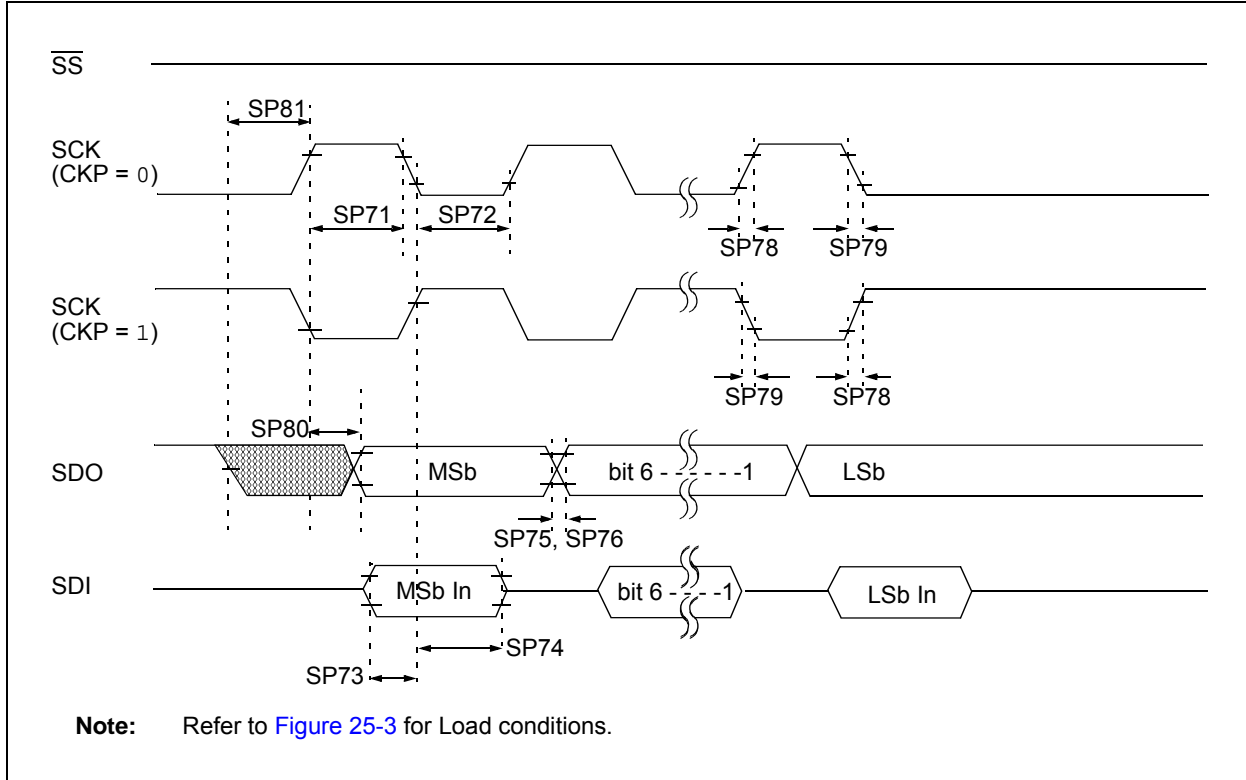

FIGURE 25-14: SPI MASTER MODE TIMING (CKE = 1, SMP = 1)

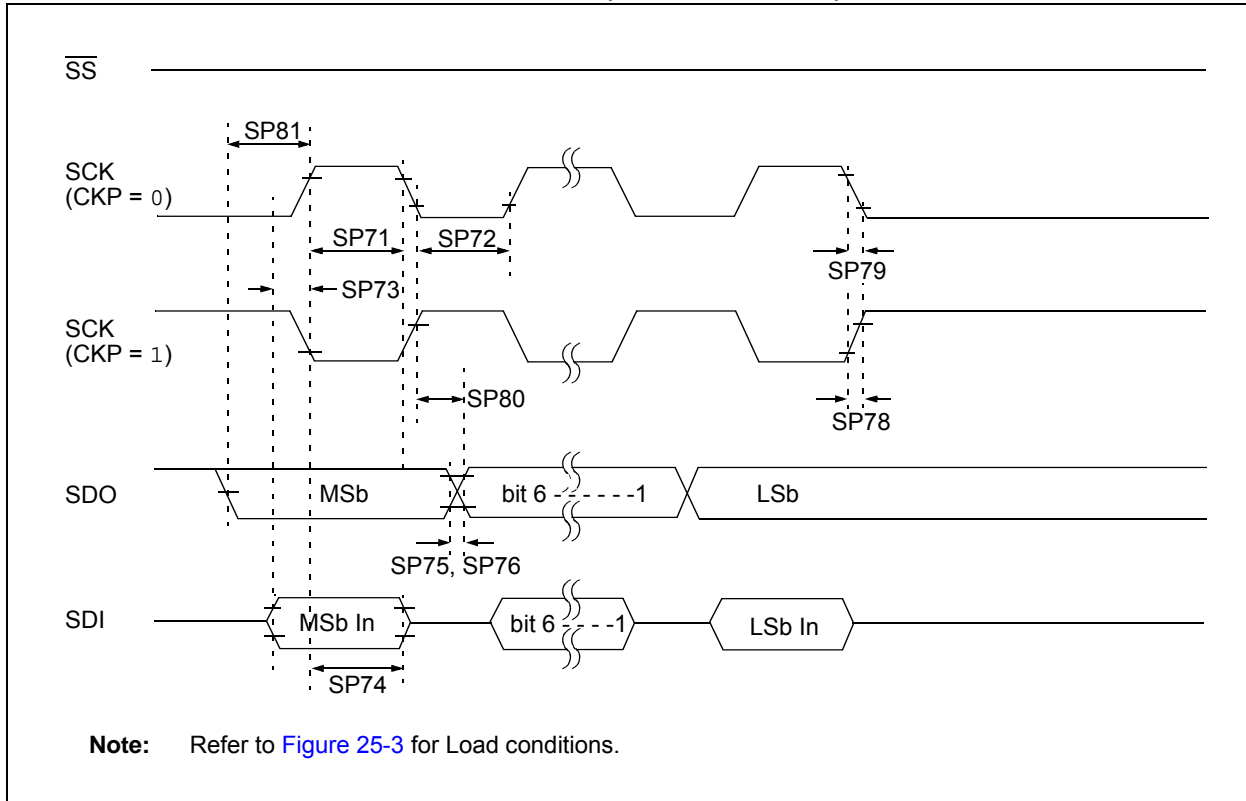

FIGURE 25-15: SPI SLAVE MODE TIMING (CKE = 0)

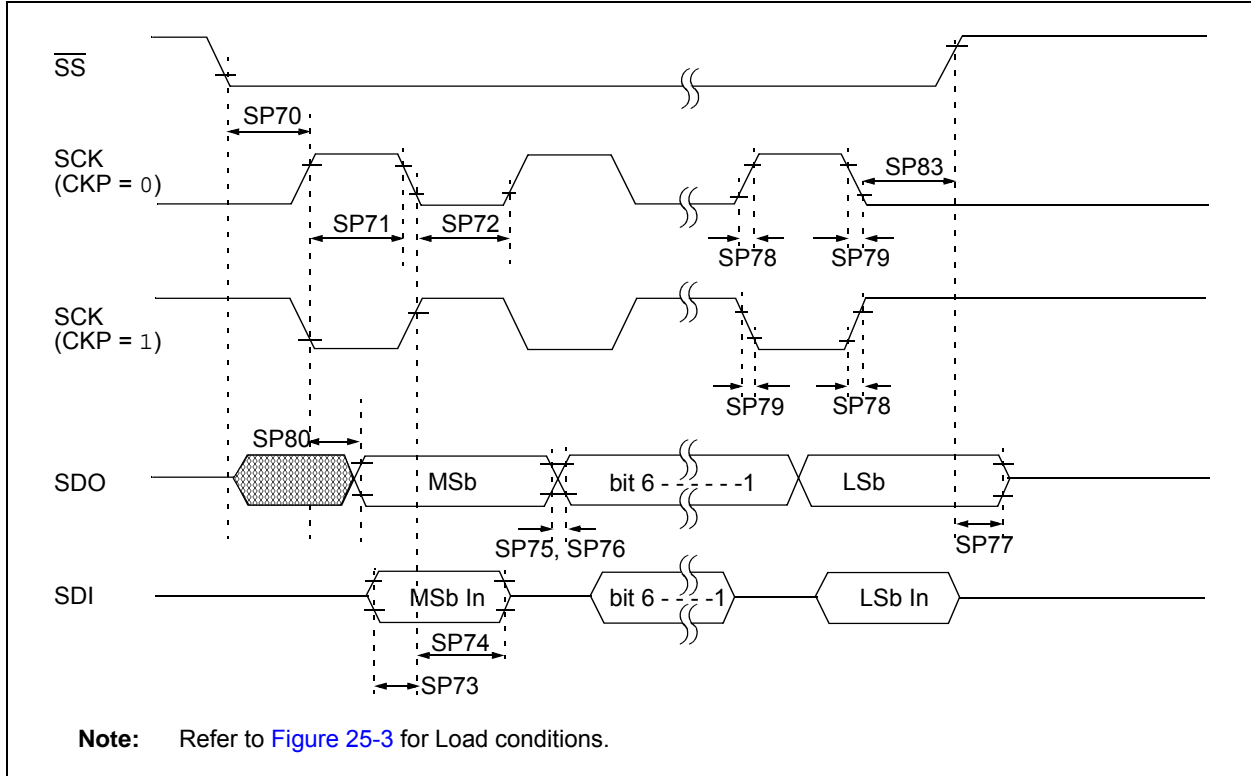
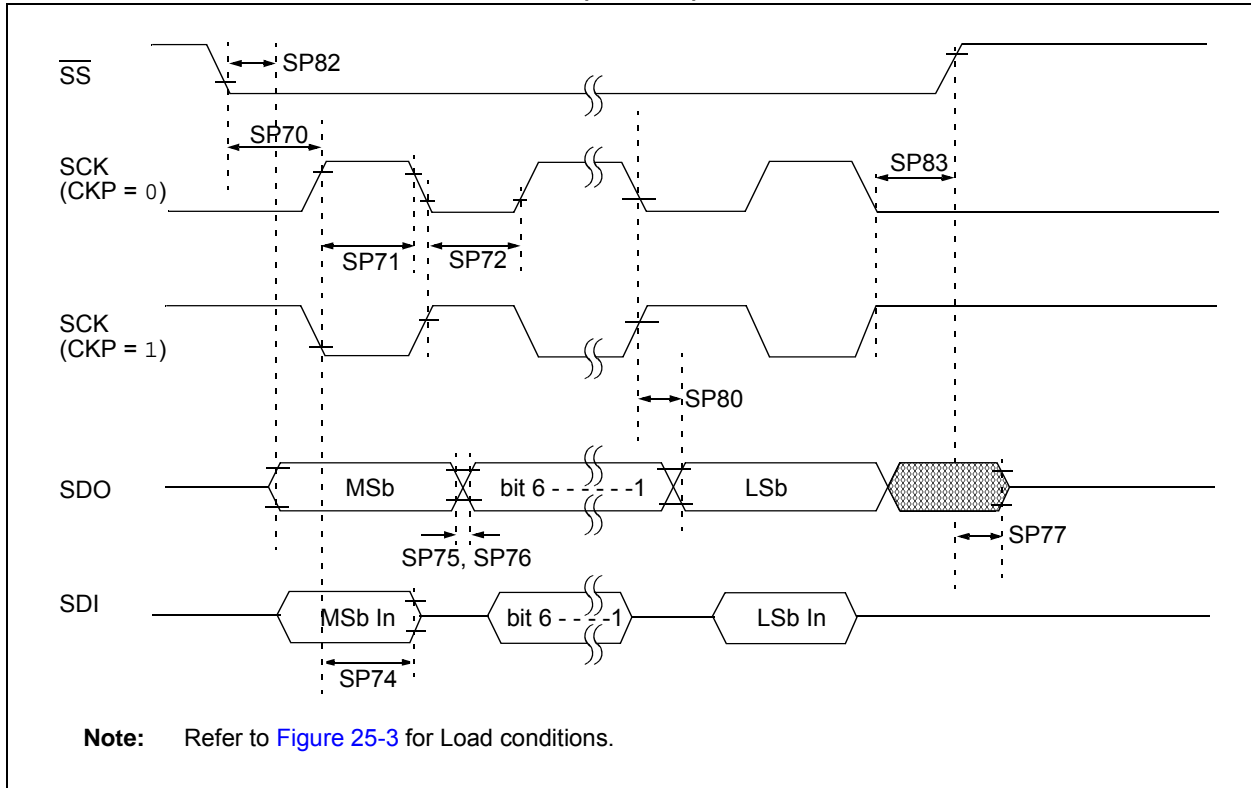

FIGURE 25-16: SPI SLAVE MODE TIMING (CKE = 1)



PIC16LF1554/1559

TABLE 25-16: SPI MODE REQUIREMENTS

Standard Operating Conditions (unless otherwise stated)							
Param. No.	Symbol	Characteristic	Min.	Typ.†	Max.	Units	Conditions
SP70*	TssL2sch, TssL2scl	$\overline{SS}\downarrow$ to SCK \downarrow or SCK \uparrow input	2.25 Tcy	—	—	ns	
SP71*	Tsch	SCK input high time (Slave mode)	1 Tcy + 20	—	—	ns	
SP72*	Tscl	SCK input low time (Slave mode)	1 Tcy + 20	—	—	ns	
SP73*	TdIV2sch, TdIV2scl	Setup time of SDI data input to SCK edge	100	—	—	ns	
SP74*	Tsch2dIL, Tscl2dIL	Hold time of SDI data input to SCK edge	100	—	—	ns	
SP75*	TdoR	SDO data output rise time	—	10	25	ns	3.0V ≤ VDD ≤ 5.5V
			—	25	50	ns	1.8V ≤ VDD ≤ 5.5V
SP76*	TdoF	SDO data output fall time	—	10	25	ns	
SP77*	TssH2doZ	$\overline{SS}\uparrow$ to SDO output high-impedance	10	—	50	ns	
SP78*	Tscr	SCK output rise time (Master mode)	—	10	25	ns	3.0V ≤ VDD ≤ 5.5V
			—	25	50	ns	1.8V ≤ VDD ≤ 5.5V
SP79*	Tscf	SCK output fall time (Master mode)	—	10	25	ns	
SP80*	Tsch2doV, Tscl2doV	SDO data output valid after SCK edge	—	—	50	ns	3.0V ≤ VDD ≤ 5.5V
			—	—	145	ns	1.8V ≤ VDD ≤ 5.5V
SP81*	TdoV2sch, TdoV2scl	SDO data output setup to SCK edge	1 Tcy	—	—	ns	
SP82*	TssL2doV	SDO data output valid after $\overline{SS}\downarrow$ edge	—	—	50	ns	
SP83*	Tsch2ssH, Tscl2ssH	$\overline{SS}\uparrow$ after SCK edge	1.5 Tcy + 40	—	—	ns	

* These parameters are characterized but not tested.

† Data in "Typ." column is at 3.0V, 25°C unless otherwise stated. These parameters are for design guidance only and are not tested.

FIGURE 25-17: I²C™ BUS START/STOP BITS TIMING

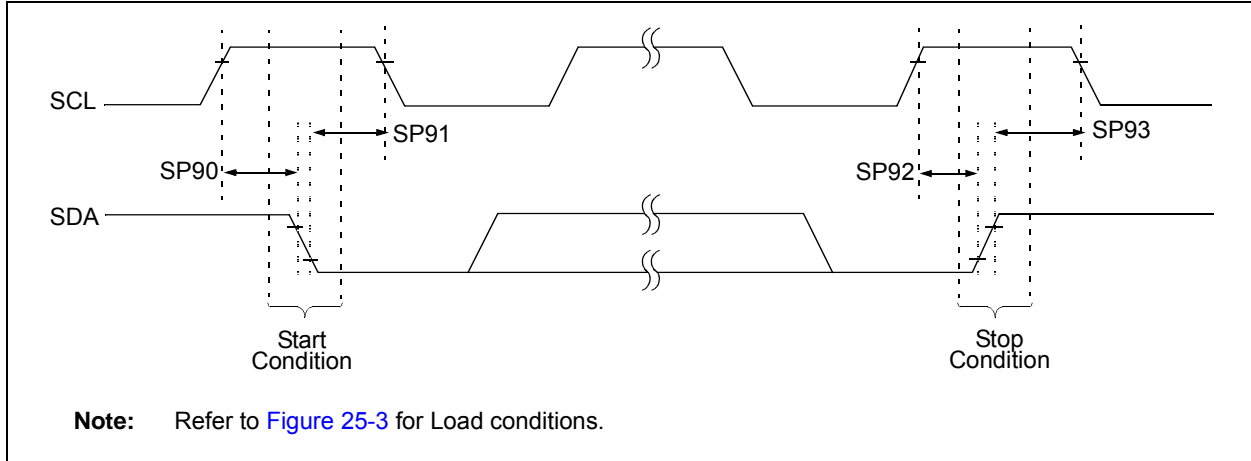
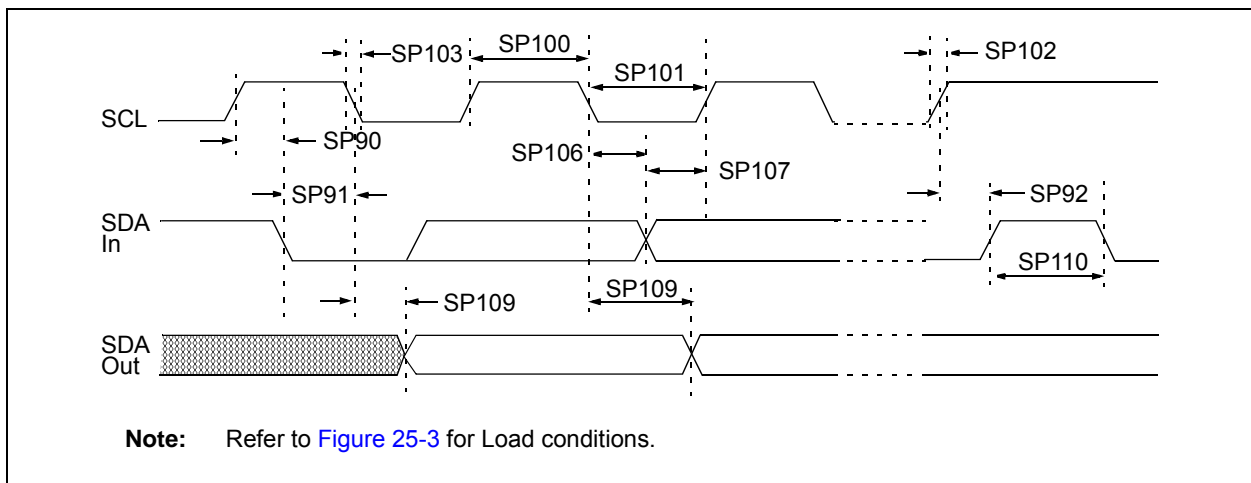

TABLE 25-17: I²C™ BUS START/STOP BITS REQUIREMENTS

Standard Operating Conditions (unless otherwise stated)								
Param. No.	Symbol	Characteristic		Min.	Typ.	Max.	Units	Conditions
SP90*	TSU:STA	Start condition	100 kHz mode	4700	—	—	ns	Only relevant for Repeated Start condition
			400 kHz mode	600	—	—		
SP91*	THD:STA	Start condition	100 kHz mode	4000	—	—	ns	After this period, the first clock pulse is generated
			400 kHz mode	600	—	—		
SP92*	TSU:STO	Stop condition	100 kHz mode	4700	—	—	ns	
			400 kHz mode	600	—	—		
SP93	THD:STO	Stop condition	100 kHz mode	4000	—	—	ns	
			400 kHz mode	600	—	—		

* These parameters are characterized but not tested.

FIGURE 25-18: I²C™ BUS DATA TIMING



PIC16LF1554/1559

TABLE 25-18: I²C™ BUS DATA REQUIREMENTS

Standard Operating Conditions (unless otherwise stated)							
Param. No.	Symbol	Characteristic		Min.	Max.	Units	Conditions
SP100*	THIGH	Clock high time	100 kHz mode	4.0	—	μs	Device must operate at a minimum of 1.5 MHz
			400 kHz mode	0.6	—	μs	Device must operate at a minimum of 10 MHz
			SSP module	1.5T _{CY}	—		
SP101*	TLOW	Clock low time	100 kHz mode	4.7	—	μs	Device must operate at a minimum of 1.5 MHz
			400 kHz mode	1.3	—	μs	Device must operate at a minimum of 10 MHz
			SSP module	1.5T _{CY}	—		
SP102*	TR	SDA and SCL rise time	100 kHz mode	—	1000	ns	
			400 kHz mode	20 + 0.1C _B	300	ns	C _B is specified to be from 10-400 pF
SP103*	TF	SDA and SCL fall time	100 kHz mode	—	250	ns	
			400 kHz mode	20 + 0.1C _B	250	ns	C _B is specified to be from 10-400 pF
SP106*	THD:DAT	Data input hold time	100 kHz mode	0	—	ns	
			400 kHz mode	0	0.9	μs	
SP107*	TSU:DAT	Data input setup time	100 kHz mode	250	—	ns	(Note 2)
			400 kHz mode	100	—	ns	
SP109*	TAA	Output valid from clock	100 kHz mode	—	3500	ns	(Note 1)
			400 kHz mode	—	—	ns	
SP110*	TBUF	Bus free time	100 kHz mode	4.7	—	μs	Time the bus must be free before a new transmission can start
			400 kHz mode	1.3	—	μs	
SP111	CB	Bus capacitive loading		—	400	pF	

* These parameters are characterized but not tested.

Note 1: As a transmitter, the device must provide this internal minimum delay time to bridge the undefined region (min. 300 ns) of the falling edge of SCL to avoid unintended generation of Start or Stop conditions.

2: A Fast mode (400 kHz) I²C™ bus device can be used in a Standard mode (100 kHz) I²C bus system, but the requirement TSU:DAT ≥ 250 ns must then be met. This will automatically be the case if the device does not stretch the low period of the SCL signal. If such a device does stretch the low period of the SCL signal, it must output the next data bit to the SDA line TR max. + TSU:DAT = 1000 + 250 = 1250 ns (according to the Standard mode I²C bus specification), before the SCL line is released.

26.0 DC AND AC CHARACTERISTICS GRAPHS AND CHARTS

Graphs and charts are not available at this time.

27.0 DEVELOPMENT SUPPORT

The PIC[®] microcontrollers (MCU) and dsPIC[®] digital signal controllers (DSC) are supported with a full range of software and hardware development tools:

- Integrated Development Environment
 - MPLAB[®] X IDE Software
- Compilers/Assemblers/Linkers
 - MPLAB XC Compiler
 - MPASM[™] Assembler
 - MPLINK[™] Object Linker/
MPLIB[™] Object Librarian
 - MPLAB Assembler/Linker/Librarian for
Various Device Families
- Simulators
 - MPLAB X SIM Software Simulator
- Emulators
 - MPLAB REAL ICE[™] In-Circuit Emulator
- In-Circuit Debuggers/Programmers
 - MPLAB ICD 3
 - PICKit[™] 3
- Device Programmers
 - MPLAB PM3 Device Programmer
- Low-Cost Demonstration/Development Boards,
Evaluation Kits and Starter Kits
- Third-party development tools

27.1 MPLAB X Integrated Development Environment Software

The MPLAB X IDE is a single, unified graphical user interface for Microchip and third-party software, and hardware development tool that runs on Windows[®], Linux and Mac OS[®] X. Based on the NetBeans IDE, MPLAB X IDE is an entirely new IDE with a host of free software components and plug-ins for high-performance application development and debugging. Moving between tools and upgrading from software simulators to hardware debugging and programming tools is simple with the seamless user interface.

With complete project management, visual call graphs, a configurable watch window and a feature-rich editor that includes code completion and context menus, MPLAB X IDE is flexible and friendly enough for new users. With the ability to support multiple tools on multiple projects with simultaneous debugging, MPLAB X IDE is also suitable for the needs of experienced users.

Feature-Rich Editor:

- Color syntax highlighting
- Smart code completion makes suggestions and provides hints as you type
- Automatic code formatting based on user-defined rules
- Live parsing

User-Friendly, Customizable Interface:

- Fully customizable interface: toolbars, toolbar buttons, windows, window placement, etc.
- Call graph window

Project-Based Workspaces:

- Multiple projects
- Multiple tools
- Multiple configurations
- Simultaneous debugging sessions

File History and Bug Tracking:

- Local file history feature
- Built-in support for Bugzilla issue tracker

27.2 MPLAB XC Compilers

The MPLAB XC Compilers are complete ANSI C compilers for all of Microchip's 8, 16, and 32-bit MCU and DSC devices. These compilers provide powerful integration capabilities, superior code optimization and ease of use. MPLAB XC Compilers run on Windows, Linux or MAC OS X.

For easy source level debugging, the compilers provide debug information that is optimized to the MPLAB X IDE.

The free MPLAB XC Compiler editions support all devices and commands, with no time or memory restrictions, and offer sufficient code optimization for most applications.

MPLAB XC Compilers include an assembler, linker and utilities. The assembler generates relocatable object files that can then be archived or linked with other relocatable object files and archives to create an executable file. MPLAB XC Compiler uses the assembler to produce its object file. Notable features of the assembler include:

- Support for the entire device instruction set
- Support for fixed-point and floating-point data
- Command-line interface
- Rich directive set
- Flexible macro language
- MPLAB X IDE compatibility

27.3 MPASM Assembler

The MPASM Assembler is a full-featured, universal macro assembler for PIC10/12/16/18 MCUs.

The MPASM Assembler generates relocatable object files for the MPLINK Object Linker, Intel® standard HEX files, MAP files to detail memory usage and symbol reference, absolute LST files that contain source lines and generated machine code, and COFF files for debugging.

The MPASM Assembler features include:

- Integration into MPLAB X IDE projects
- User-defined macros to streamline assembly code
- Conditional assembly for multipurpose source files
- Directives that allow complete control over the assembly process

27.4 MPLINK Object Linker/ MPLIB Object Librarian

The MPLINK Object Linker combines relocatable objects created by the MPASM Assembler. It can link relocatable objects from precompiled libraries, using directives from a linker script.

The MPLIB Object Librarian manages the creation and modification of library files of precompiled code. When a routine from a library is called from a source file, only the modules that contain that routine will be linked in with the application. This allows large libraries to be used efficiently in many different applications.

The object linker/librarian features include:

- Efficient linking of single libraries instead of many smaller files
- Enhanced code maintainability by grouping related modules together
- Flexible creation of libraries with easy module listing, replacement, deletion and extraction

27.5 MPLAB Assembler, Linker and Librarian for Various Device Families

MPLAB Assembler produces relocatable machine code from symbolic assembly language for PIC24, PIC32 and dsPIC DSC devices. MPLAB XC Compiler uses the assembler to produce its object file. The assembler generates relocatable object files that can then be archived or linked with other relocatable object files and archives to create an executable file. Notable features of the assembler include:

- Support for the entire device instruction set
- Support for fixed-point and floating-point data
- Command-line interface
- Rich directive set
- Flexible macro language
- MPLAB X IDE compatibility

PIC16LF1554/1559

27.6 MPLAB X SIM Software Simulator

The MPLAB X SIM Software Simulator allows code development in a PC-hosted environment by simulating the PIC MCUs and dsPIC DSCs on an instruction level. On any given instruction, the data areas can be examined or modified and stimuli can be applied from a comprehensive stimulus controller. Registers can be logged to files for further run-time analysis. The trace buffer and logic analyzer display extend the power of the simulator to record and track program execution, actions on I/O, most peripherals and internal registers.

The MPLAB X SIM Software Simulator fully supports symbolic debugging using the MPLAB XC Compilers, and the MPASM and MPLAB Assemblers. The software simulator offers the flexibility to develop and debug code outside of the hardware laboratory environment, making it an excellent, economical software development tool.

27.7 MPLAB REAL ICE In-Circuit Emulator System

The MPLAB REAL ICE In-Circuit Emulator System is Microchip's next generation high-speed emulator for Microchip Flash DSC and MCU devices. It debugs and programs all 8, 16 and 32-bit MCU, and DSC devices with the easy-to-use, powerful graphical user interface of the MPLAB X IDE.

The emulator is connected to the design engineer's PC using a high-speed USB 2.0 interface and is connected to the target with either a connector compatible with in-circuit debugger systems (RJ-11) or with the new high-speed, noise tolerant, Low-Voltage Differential Signal (LVDS) interconnection (CAT5).

The emulator is field upgradable through future firmware downloads in MPLAB X IDE. MPLAB REAL ICE offers significant advantages over competitive emulators including full-speed emulation, run-time variable watches, trace analysis, complex breakpoints, logic probes, a ruggedized probe interface and long (up to three meters) interconnection cables.

27.8 MPLAB ICD 3 In-Circuit Debugger System

The MPLAB ICD 3 In-Circuit Debugger System is Microchip's most cost-effective, high-speed hardware debugger/programmer for Microchip Flash DSC and MCU devices. It debugs and programs PIC Flash microcontrollers and dsPIC DSCs with the powerful, yet easy-to-use graphical user interface of the MPLAB IDE.

The MPLAB ICD 3 In-Circuit Debugger probe is connected to the design engineer's PC using a high-speed USB 2.0 interface and is connected to the target with a connector compatible with the MPLAB ICD 2 or MPLAB REAL ICE systems (RJ-11). MPLAB ICD 3 supports all MPLAB ICD 2 headers.

27.9 PICkit 3 In-Circuit Debugger/Programmer

The MPLAB PICkit 3 allows debugging and programming of PIC and dsPIC Flash microcontrollers at a most affordable price point using the powerful graphical user interface of the MPLAB IDE. The MPLAB PICkit 3 is connected to the design engineer's PC using a full-speed USB interface and can be connected to the target via a Microchip debug (RJ-11) connector (compatible with MPLAB ICD 3 and MPLAB REAL ICE). The connector uses two device I/O pins and the Reset line to implement in-circuit debugging and In-Circuit Serial Programming™ (ICSP™).

27.10 MPLAB PM3 Device Programmer

The MPLAB PM3 Device Programmer is a universal, CE compliant device programmer with programmable voltage verification at VDDMIN and VDDMAX for maximum reliability. It features a large LCD display (128 x 64) for menus and error messages, and a modular, detachable socket assembly to support various package types. The ICSP cable assembly is included as a standard item. In Stand-Alone mode, the MPLAB PM3 Device Programmer can read, verify and program PIC devices without a PC connection. It can also set code protection in this mode. The MPLAB PM3 connects to the host PC via an RS-232 or USB cable. The MPLAB PM3 has high-speed communications and optimized algorithms for quick programming of large memory devices, and incorporates an MMC card for file storage and data applications.

27.11 Demonstration/Development Boards, Evaluation Kits, and Starter Kits

A wide variety of demonstration, development and evaluation boards for various PIC MCUs and dsPIC DSCs allows quick application development on fully functional systems. Most boards include prototyping areas for adding custom circuitry and provide application firmware and source code for examination and modification.

The boards support a variety of features, including LEDs, temperature sensors, switches, speakers, RS-232 interfaces, LCD displays, potentiometers and additional EEPROM memory.

The demonstration and development boards can be used in teaching environments, for prototyping custom circuits and for learning about various microcontroller applications.

In addition to the PICDEM™ and dsPICDEM™ demonstration/development board series of circuits, Microchip has a line of evaluation kits and demonstration software for analog filter design, KEELOQ® security ICs, CAN, IrDA®, PowerSmart battery management, Sigma-Delta ADC, flow rate sensing, plus many more.

Also available are starter kits that contain everything needed to experience the specified device. This usually includes a single application and debug capability, all on one board.

Check the Microchip web page (www.microchip.com) for the complete list of demonstration, development and evaluation kits.

27.12 Third-Party Development Tools

Microchip also offers a great collection of tools from third-party vendors. These tools are carefully selected to offer good value and unique functionality.

- Device Programmers and Gang Programmers from companies, such as SoftLog and CCS
- Software Tools from companies, such as Gimpel and Trace Systems
- Protocol Analyzers from companies, such as Saleae and Total Phase
- Demonstration Boards from companies, such as MikroElektronika, Digilent® and Olimex
- Embedded Ethernet Solutions from companies, such as EZ Web Lynx, WIZnet and IPLogika®

PIC16LF1554/1559

28.0 PACKAGING INFORMATION

28.1 Package Marking Information

14-Lead PDIP (300 mil)

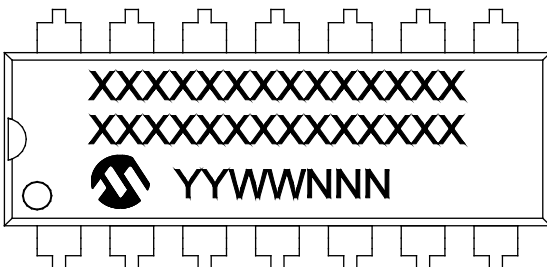

Example

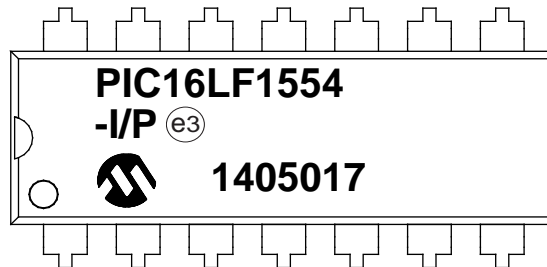

14-Lead SOIC (3.90 mm)

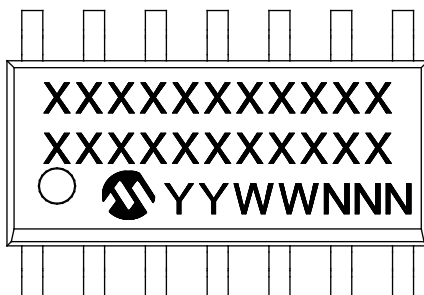

Example

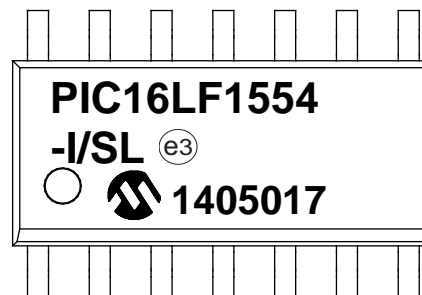

Legend:	XX...X	Customer-specific information
	Y	Year code (last digit of calendar year)
	YY	Year code (last 2 digits of calendar year)
	WW	Week code (week of January 1 is week '01')
	NNN	Alphanumeric traceability code
	e3	Pb-free JEDEC® designator for Matte Tin (Sn)
	*	This package is Pb-free. The Pb-free JEDEC designator (e3) can be found on the outer packaging for this package.
Note:	In the event the full Microchip part number cannot be marked on one line, it will be carried over to the next line, thus limiting the number of available characters for customer-specific information.	

Package Marking Information (Continued)

14-Lead TSSOP (4.4 mm)

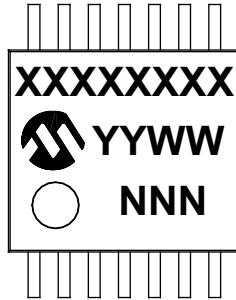

Example

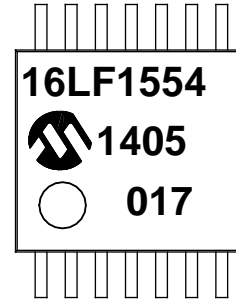

16-Lead QFN (4x4x0.9 mm)

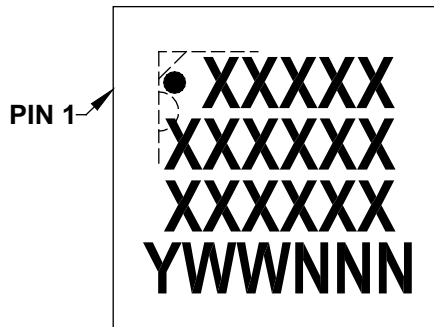

Example

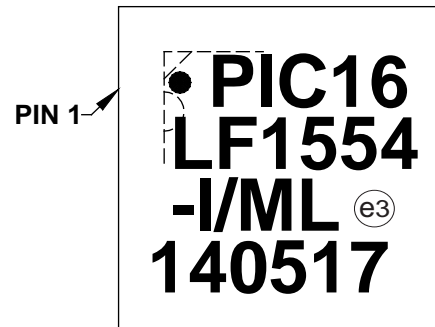

Legend:	XX...X	Customer-specific information
	Y	Year code (last digit of calendar year)
	YY	Year code (last 2 digits of calendar year)
	WW	Week code (week of January 1 is week '01')
	NNN	Alphanumeric traceability code
	(e3)	Pb-free JEDEC® designator for Matte Tin (Sn)
	*	This package is Pb-free. The Pb-free JEDEC designator (e3) can be found on the outer packaging for this package.

Note: In the event the full Microchip part number cannot be marked on one line, it will be carried over to the next line, thus limiting the number of available characters for customer-specific information.

PIC16LF1554/1559

Package Marking Information (Continued)

20-Lead PDIP (300 mil)

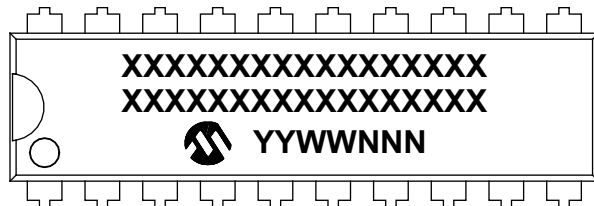

Example

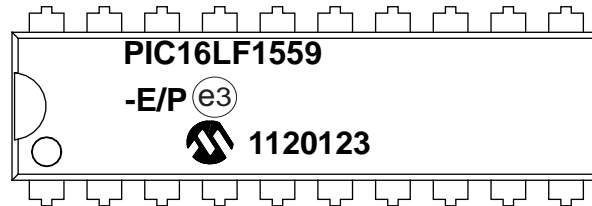

20-Lead SSOP (5.30 mm)

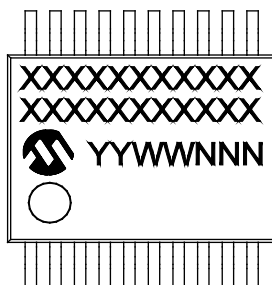

Example

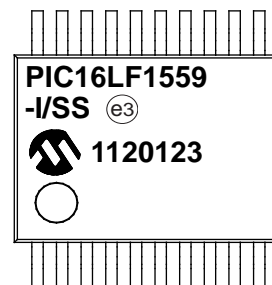

Legend:	XX...X	Customer-specific information
	Y	Year code (last digit of calendar year)
	YY	Year code (last 2 digits of calendar year)
	WW	Week code (week of January 1 is week '01')
	NNN	Alphanumeric traceability code
	(e3)	Pb-free JEDEC® designator for Matte Tin (Sn)
	*	This package is Pb-free. The Pb-free JEDEC designator (e3) can be found on the outer packaging for this package.
Note:	In the event the full Microchip part number cannot be marked on one line, it will be carried over to the next line, thus limiting the number of available characters for customer-specific information.	

Package Marking Information (Continued)

20-Lead QFN (4x4x0.9 mm)

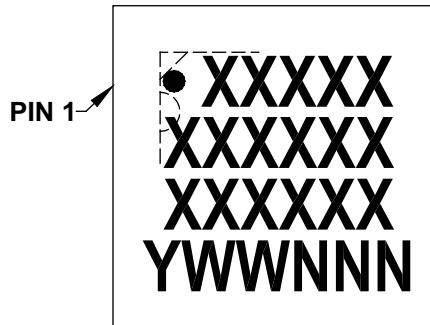

Example

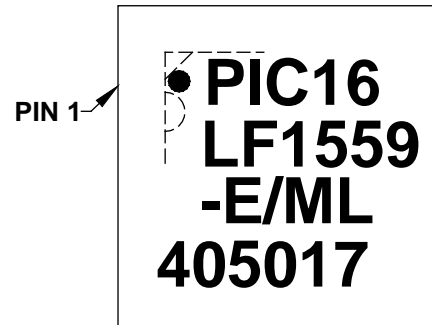

Legend:	XX...X	Customer-specific information
	Y	Year code (last digit of calendar year)
	YY	Year code (last 2 digits of calendar year)
	WW	Week code (week of January 1 is week '01')
	NNN	Alphanumeric traceability code
	(e3)	Pb-free JEDEC [®] designator for Matte Tin (Sn)
	*	This package is Pb-free. The Pb-free JEDEC designator (e3) can be found on the outer packaging for this package.

Note: In the event the full Microchip part number cannot be marked on one line, it will be carried over to the next line, thus limiting the number of available characters for customer-specific information.

PIC16LF1554/1559

28.2 Package Details

The following sections give the technical details of the packages.

14-Lead Plastic Dual In-Line (P) – 300 mil Body [PDIP]

Note: For the most current package drawings, please see the Microchip Packaging Specification located at <http://www.microchip.com/packaging>

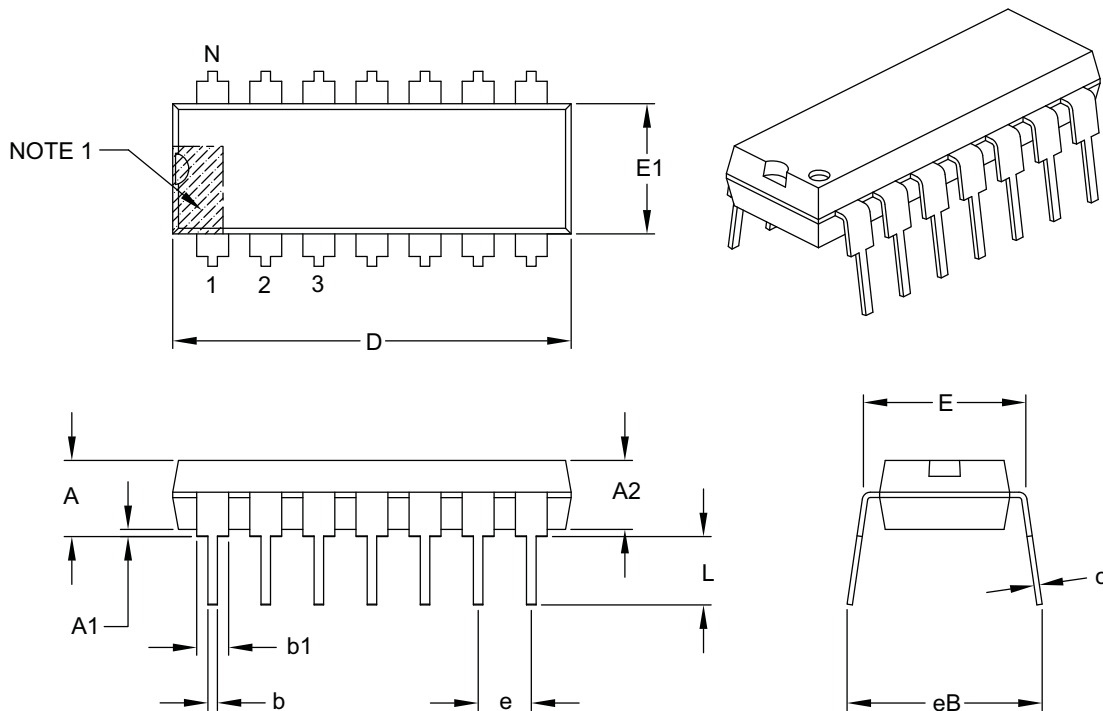

Dimension Limits	Units	INCHES		
		MIN	NOM	MAX
Number of Pins	N	14		
Pitch	e	.100 BSC		
Top to Seating Plane	A	–	–	.210
Molded Package Thickness	A2	.115	.130	.195
Base to Seating Plane	A1	.015	–	–
Shoulder to Shoulder Width	E	.290	.310	.325
Molded Package Width	E1	.240	.250	.280
Overall Length	D	.735	.750	.775
Tip to Seating Plane	L	.115	.130	.150
Lead Thickness	c	.008	.010	.015
Upper Lead Width	b1	.045	.060	.070
Lower Lead Width	b	.014	.018	.022
Overall Row Spacing §	eB	–	–	.430

Notes:

- Pin 1 visual index feature may vary, but must be located with the hatched area.
- § Significant Characteristic.
- Dimensions D and E1 do not include mold flash or protrusions. Mold flash or protrusions shall not exceed .010" per side.
- Dimensioning and tolerancing per ASME Y14.5M.

BSC: Basic Dimension. Theoretically exact value shown without tolerances.

Microchip Technology Drawing C04-005B

PIC16LF1554/1559

14-Lead Plastic Small Outline (SL) - Narrow, 3.90 mm Body [SOIC]

Note: For the most current package drawings, please see the Microchip Packaging Specification located at <http://www.microchip.com/packaging>

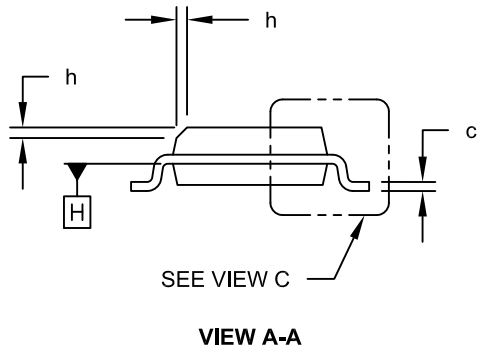
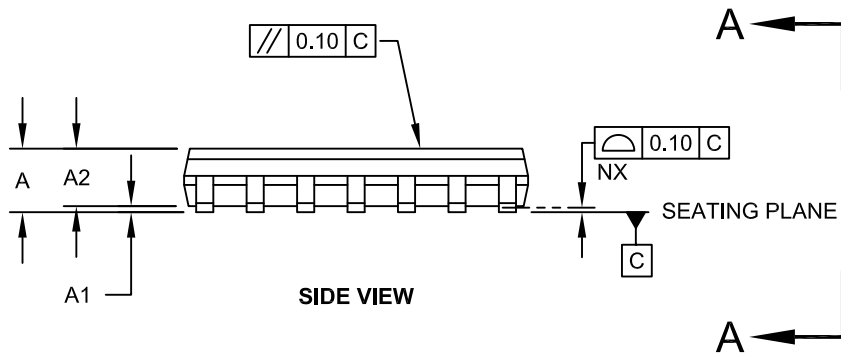
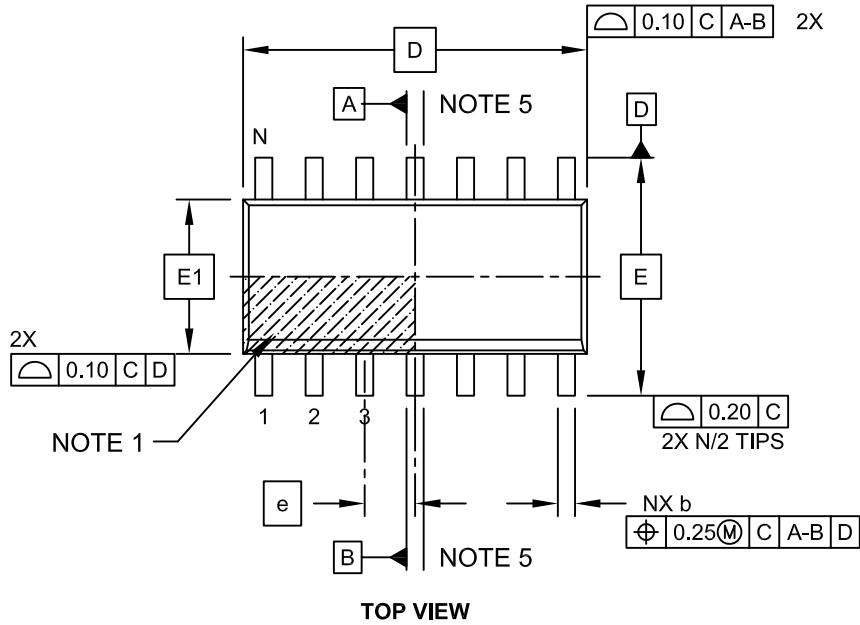

Microchip Technology Drawing No. C04-065C Sheet 1 of 2

PIC16LF1554/1559

14-Lead Plastic Small Outline (SL) - Narrow, 3.90 mm Body [SOIC]

Note: For the most current package drawings, please see the Microchip Packaging Specification located at <http://www.microchip.com/packaging>

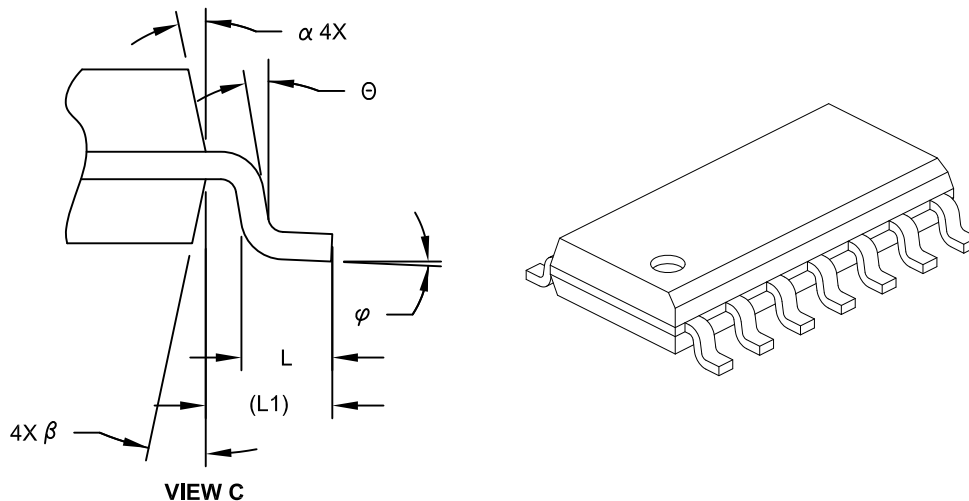

		MILLIMETERS		
Units		MIN	NOM	MAX
Dimension Limits				
Number of Pins	N	14		
Pitch	e	1.27 BSC		
Overall Height	A	-	-	1.75
Molded Package Thickness	A2	1.25	-	-
Standoff §	A1	0.10	-	0.25
Overall Width	E	6.00 BSC		
Molded Package Width	E1	3.90 BSC		
Overall Length	D	8.65 BSC		
Chamfer (Optional)	h	0.25	-	0.50
Foot Length	L	0.40	-	1.27
Footprint	L1	1.04 REF		
Lead Angle	Θ	0°	-	-
Foot Angle	φ	0°	-	8°
Lead Thickness	c	0.10	-	0.25
Lead Width	b	0.31	-	0.51
Mold Draft Angle Top	α	5°	-	15°
Mold Draft Angle Bottom	β	5°	-	15°

Notes:

- Pin 1 visual index feature may vary, but must be located within the hatched area.
- § Significant Characteristic
- Dimension D does not include mold flash, protrusions or gate burrs, which shall not exceed 0.15 mm per end. Dimension E1 does not include interlead flash or protrusion, which shall not exceed 0.25 mm per side.
- Dimensioning and tolerancing per ASME Y14.5M
BSC: Basic Dimension. Theoretically exact value shown without tolerances.
REF: Reference Dimension, usually without tolerance, for information purposes only.
- Datums A & B to be determined at Datum H.

Microchip Technology Drawing No. C04-065C Sheet 2 of 2

PIC16LF1554/1559

14-Lead Plastic Small Outline (SL) - Narrow, 3.90 mm Body [SOIC]

Note: For the most current package drawings, please see the Microchip Packaging Specification located at <http://www.microchip.com/packageing>

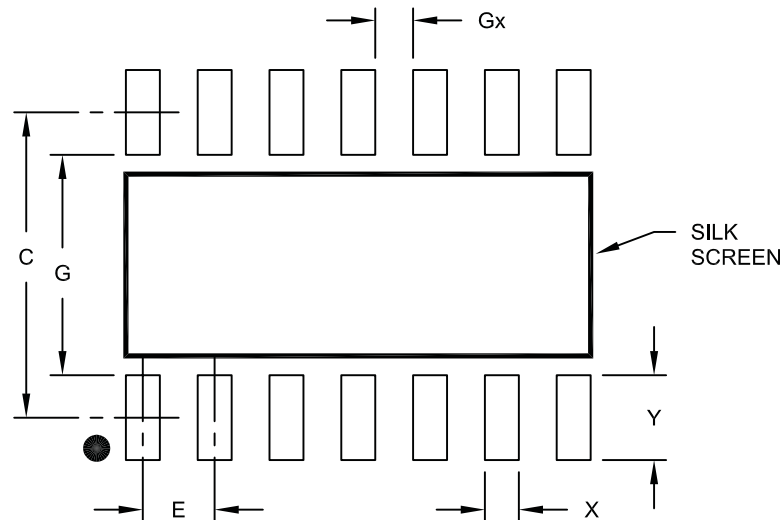

RECOMMENDED LAND PATTERN

Dimension Limits	Units	MILLIMETERS		
		MIN	NOM	MAX
Contact Pitch	E	1.27 BSC		
Contact Pad Spacing	C		5.40	
Contact Pad Width	X			0.60
Contact Pad Length	Y			1.50
Distance Between Pads	Gx	0.67		
Distance Between Pads	G	3.90		

Notes:

1. Dimensioning and tolerancing per ASME Y14.5M

BSC: Basic Dimension. Theoretically exact value shown without tolerances.

Microchip Technology Drawing No. C04-2065A

PIC16LF1554/1559

14-Lead Plastic Thin Shrink Small Outline (ST) - 4.4 mm Body [TSSOP]

Note: For the most current package drawings, please see the Microchip Packaging Specification located at <http://www.microchip.com/packaging>

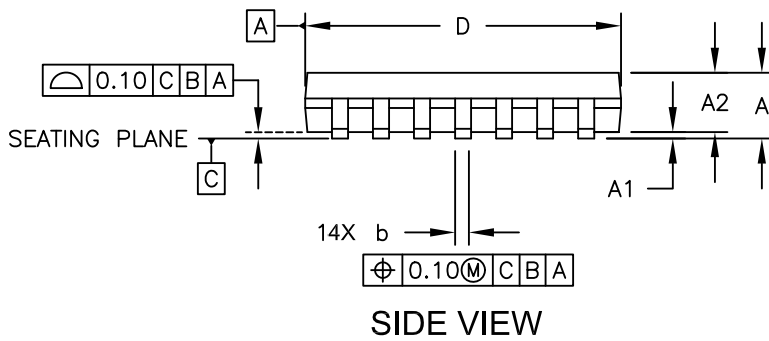
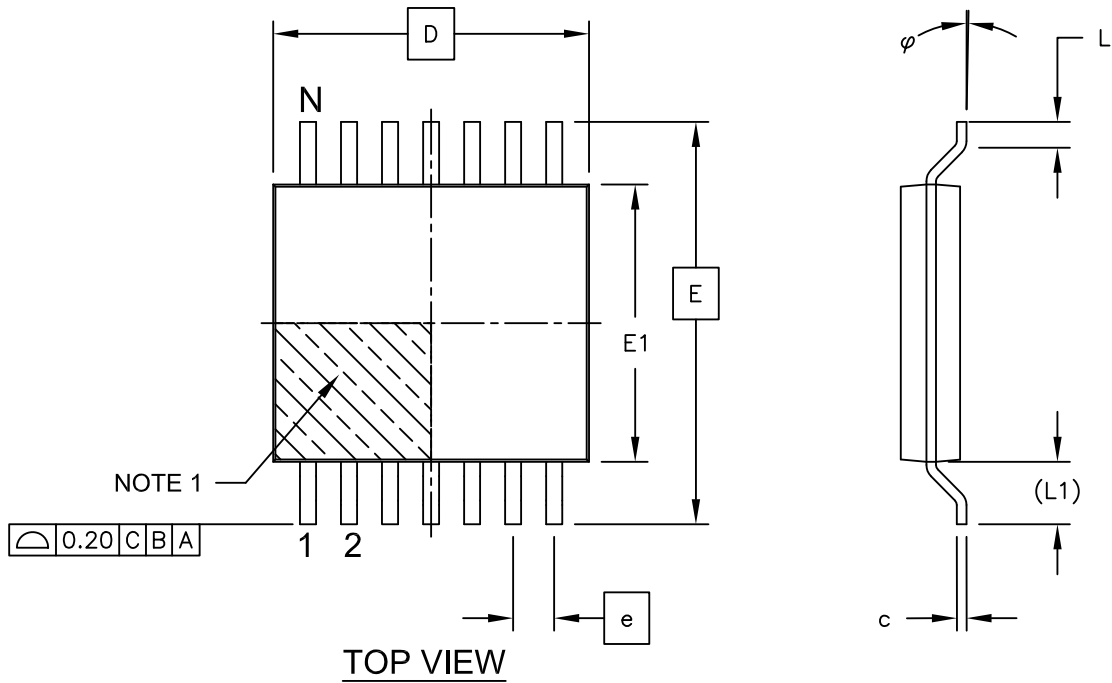

Microchip Technology Drawing C04-087C Sheet 1 of 2

PIC16LF1554/1559

14-Lead Plastic Thin Shrink Small Outline (ST) - 4.4 mm Body [TSSOP]

Note: For the most current package drawings, please see the Microchip Packaging Specification located at <http://www.microchip.com/packaging>

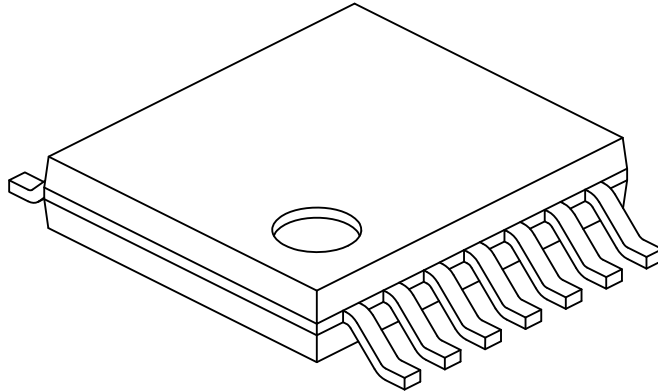

Dimension Limits	Units	MILLIMETERS		
		MIN	NOM	MAX
Number of Pins	N	14		
Pitch	e	0.65 BSC		
Overall Height	A	-	-	1.20
Molded Package Thickness	A2	0.80	1.00	1.05
Standoff	A1	0.05	-	0.15
Overall Width	E	6.40 BSC		
Molded Package Width	E1	4.30	4.40	4.50
Molded Package Length	D	4.90	5.00	5.10
Foot Length	L	0.45	0.60	0.75
Footprint	(L1)	1.00 REF		
Foot Angle	φ	0°	-	8°
Lead Thickness	c	0.09	-	0.20
Lead Width	b	0.19	-	0.30

Notes:

1. Pin 1 visual index feature may vary, but must be located within the hatched area.
2. Dimensions D and E1 do not include mold flash or protrusions. Mold flash or protrusions shall not exceed 0.15mm per side.
3. Dimensioning and tolerancing per ASME Y14.5M

BSC: Basic Dimension, Theoretically exact value shown without tolerances.

REF: Reference Dimension, usually without tolerance, for information purposes only.

Microchip Technology Drawing No. C04-087C Sheet 2 of 2

PIC16LF1554/1559

14-Lead Plastic Thin Shrink Small Outline (ST) - 4.4 mm Body [TSSOP]

Note: For the most current package drawings, please see the Microchip Packaging Specification located at <http://www.microchip.com/packaging>

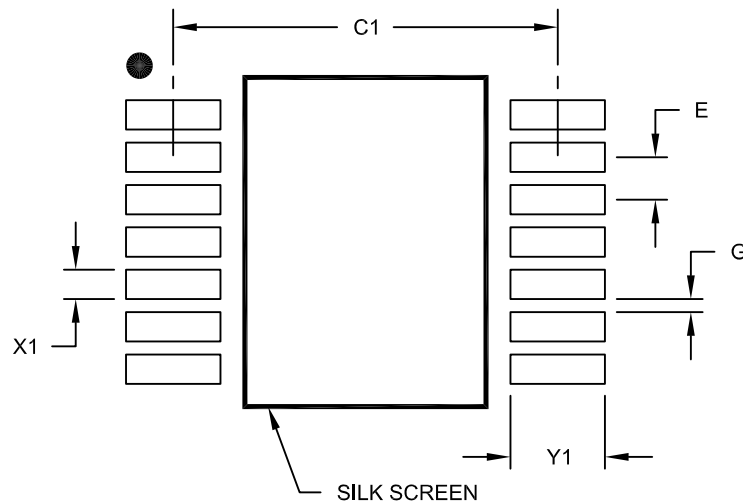

RECOMMENDED LAND PATTERN

Dimension Limits	Units	MILLIMETERS		
		MIN	NOM	MAX
Contact Pitch	E	0.65 BSC		
Contact Pad Spacing	C1		5.90	
Contact Pad Width (X14)	X1			0.45
Contact Pad Length (X14)	Y1			1.45
Distance Between Pads	G	0.20		

Notes:

1. Dimensioning and tolerancing per ASME Y14.5M

BSC: Basic Dimension. Theoretically exact value shown without tolerances.

Microchip Technology Drawing No. C04-2087A

PIC16LF1554/1559

16-Lead Plastic Quad Flat, No Lead Package (ML) – 4x4x0.9 mm Body [QFN]

Note: For the most current package drawings, please see the Microchip Packaging Specification located at <http://www.microchip.com/packaging>

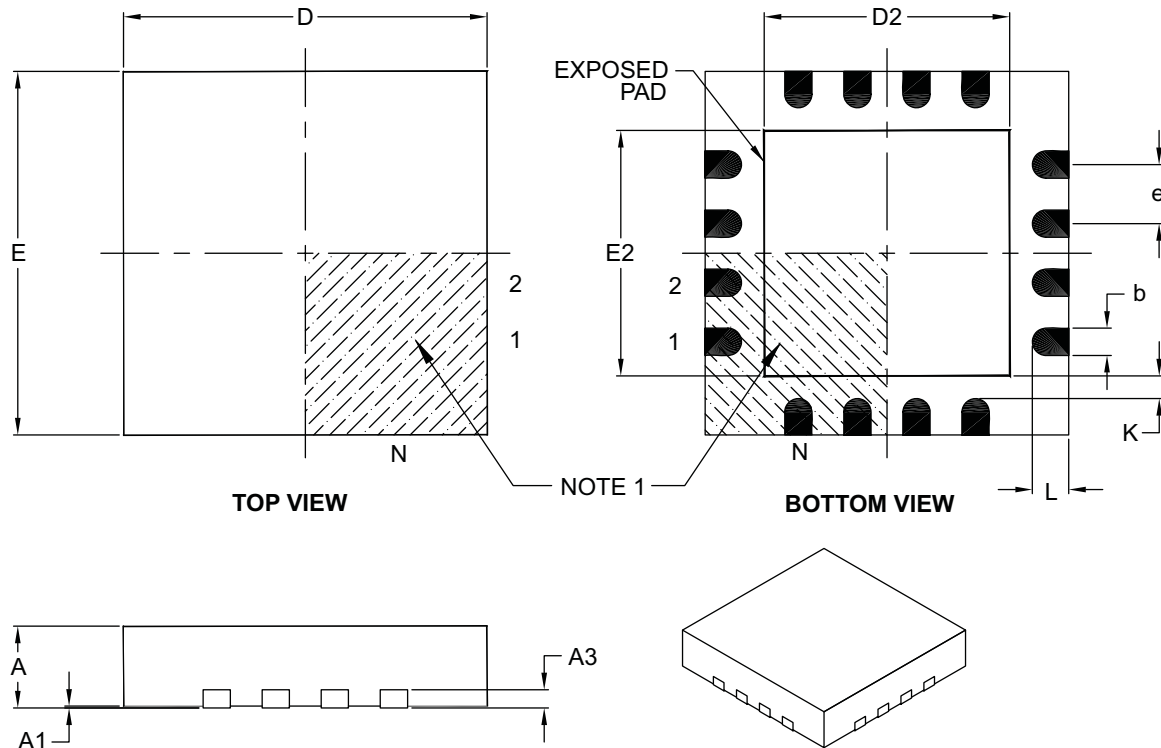

Dimension Limits	Units	MILLIMETERS		
		MIN	NOM	MAX
Number of Pins	N	16		
Pitch	e	0.65 BSC		
Overall Height	A	0.80	0.90	1.00
Standoff	A1	0.00	0.02	0.05
Contact Thickness	A3	0.20 REF		
Overall Width	E	4.00 BSC		
Exposed Pad Width	E2	2.50	2.65	2.80
Overall Length	D	4.00 BSC		
Exposed Pad Length	D2	2.50	2.65	2.80
Contact Width	b	0.25	0.30	0.35
Contact Length	L	0.30	0.40	0.50
Contact-to-Exposed Pad	K	0.20	–	–

Notes:

- Pin 1 visual index feature may vary, but must be located within the hatched area.
- Package is saw singulated.
- Dimensioning and tolerancing per ASME Y14.5M.

BSC: Basic Dimension. Theoretically exact value shown without tolerances.

REF: Reference Dimension, usually without tolerance, for information purposes only.

Microchip Technology Drawing C04-127B

PIC16LF1554/1559

16-Lead Plastic Quad Flat, No Lead Package (ML) - 4x4x0.9mm Body [QFN]

Note: For the most current package drawings, please see the Microchip Packaging Specification located at <http://www.microchip.com/packaging>

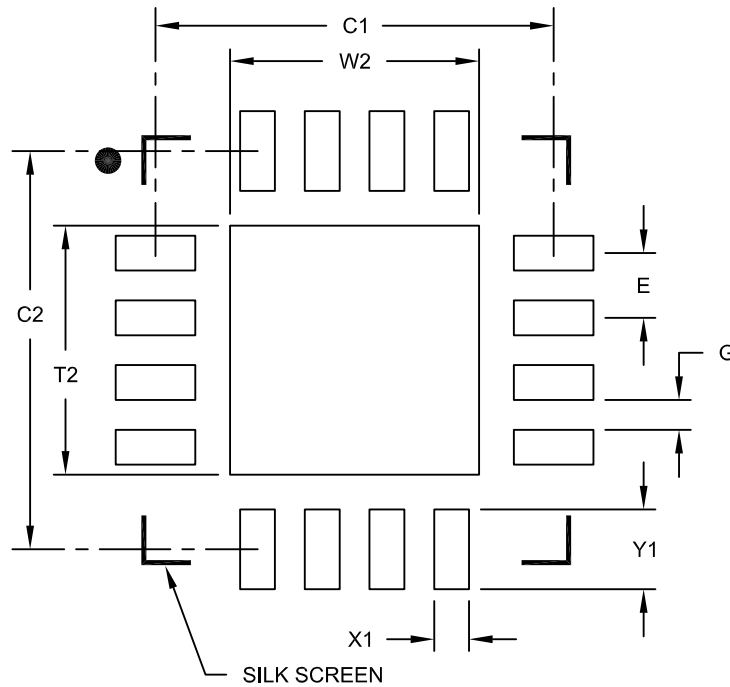

RECOMMENDED LAND PATTERN

Dimension Limits	Units	MILLIMETERS		
		MIN	NOM	MAX
Contact Pitch	E		0.65 BSC	
Optional Center Pad Width	W2			2.50
Optional Center Pad Length	T2			2.50
Contact Pad Spacing	C1		4.00	
Contact Pad Spacing	C2		4.00	
Contact Pad Width (X16)	X1			0.35
Contact Pad Length (X16)	Y1			0.80
Distance Between Pads	G	0.30		

Notes:

1. Dimensioning and tolerancing per ASME Y14.5M

BSC: Basic Dimension. Theoretically exact value shown without tolerances.

Microchip Technology Drawing No. C04-2127A

PIC16LF1554/1559

20-Lead Plastic Dual In-Line (P) – 300 mil Body [PDIP]

Note: For the most current package drawings, please see the Microchip Packaging Specification located at <http://www.microchip.com/packaging>

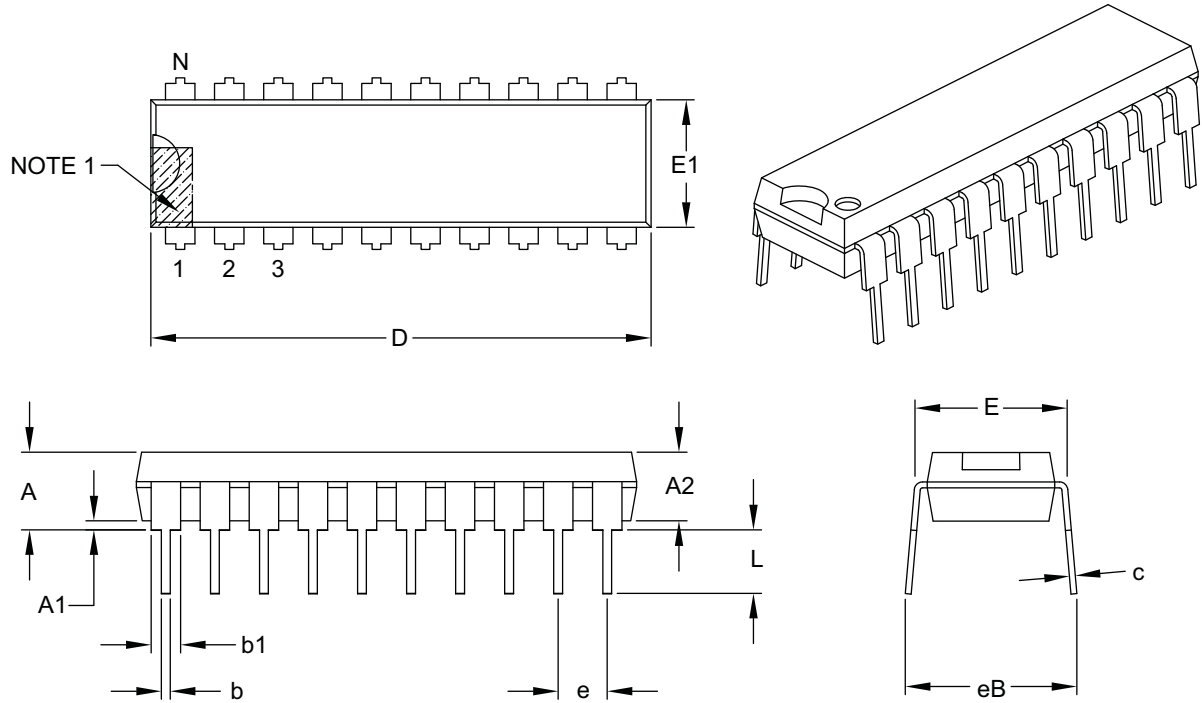

Dimension Limits	Units	INCHES		
		MIN	NOM	MAX
Number of Pins	N	20		
Pitch	e	.100 BSC		
Top to Seating Plane	A	–	–	.210
Molded Package Thickness	A2	.115	.130	.195
Base to Seating Plane	A1	.015	–	–
Shoulder to Shoulder Width	E	.300	.310	.325
Molded Package Width	E1	.240	.250	.280
Overall Length	D	.980	1.030	1.060
Tip to Seating Plane	L	.115	.130	.150
Lead Thickness	c	.008	.010	.015
Upper Lead Width	b1	.045	.060	.070
Lower Lead Width	b	.014	.018	.022
Overall Row Spacing §	eB	–	–	.430

Notes:

- Pin 1 visual index feature may vary, but must be located within the hatched area.
- § Significant Characteristic.
- Dimensions D and E1 do not include mold flash or protrusions. Mold flash or protrusions shall not exceed .010" per side.
- Dimensioning and tolerancing per ASME Y14.5M.

BSC: Basic Dimension. Theoretically exact value shown without tolerances.

Microchip Technology Drawing C04-019B

PIC16LF1554/1559

20-Lead Plastic Shrink Small Outline (SS) – 5.30 mm Body [SSOP]

Note: For the most current package drawings, please see the Microchip Packaging Specification located at <http://www.microchip.com/packaging>

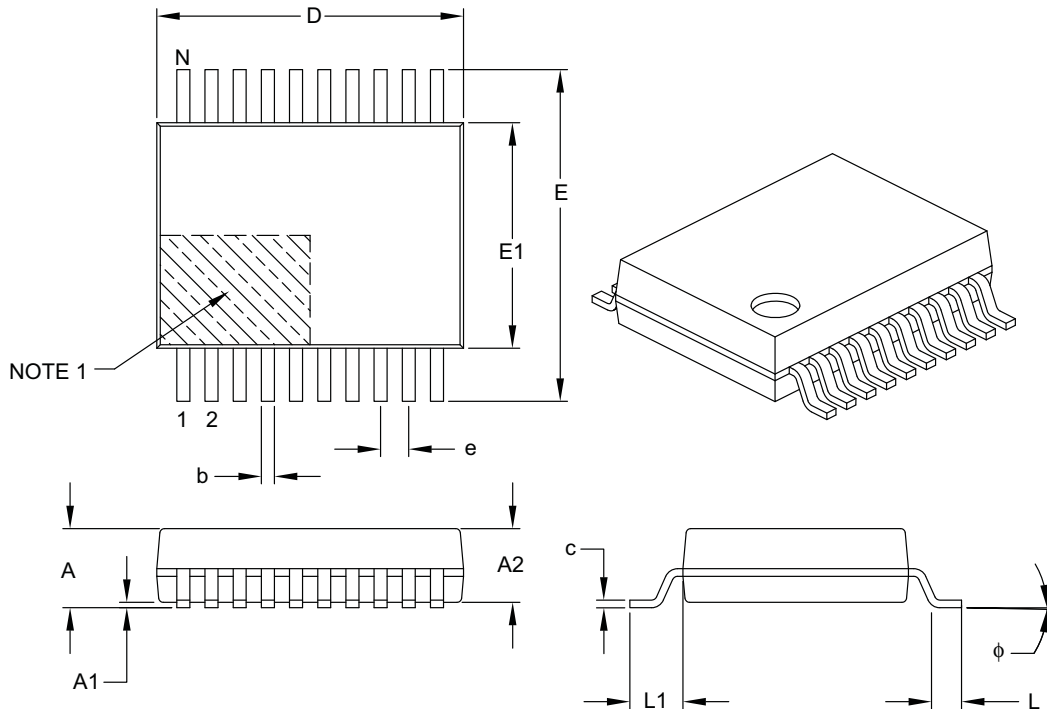

Dimension Limits	Units	MILLIMETERS		
		MIN	NOM	MAX
Number of Pins	N	20		
Pitch	e	0.65 BSC		
Overall Height	A	–	–	2.00
Molded Package Thickness	A2	1.65	1.75	1.85
Standoff	A1	0.05	–	–
Overall Width	E	7.40	7.80	8.20
Molded Package Width	E1	5.00	5.30	5.60
Overall Length	D	6.90	7.20	7.50
Foot Length	L	0.55	0.75	0.95
Footprint	L1	1.25 REF		
Lead Thickness	c	0.09	–	0.25
Foot Angle	ϕ	0°	4°	8°
Lead Width	b	0.22	–	0.38

Notes:

- Pin 1 visual index feature may vary, but must be located within the hatched area.
- Dimensions D and E1 do not include mold flash or protrusions. Mold flash or protrusions shall not exceed 0.20 mm per side.
- Dimensioning and tolerancing per ASME Y14.5M.

BSC: Basic Dimension. Theoretically exact value shown without tolerances.

REF: Reference Dimension, usually without tolerance, for information purposes only.

Microchip Technology Drawing C04-072B

PIC16LF1554/1559

20-Lead Plastic Shrink Small Outline (SS) - 5.30 mm Body [SSOP]

Note: For the most current package drawings, please see the Microchip Packaging Specification located at <http://www.microchip.com/packaging>

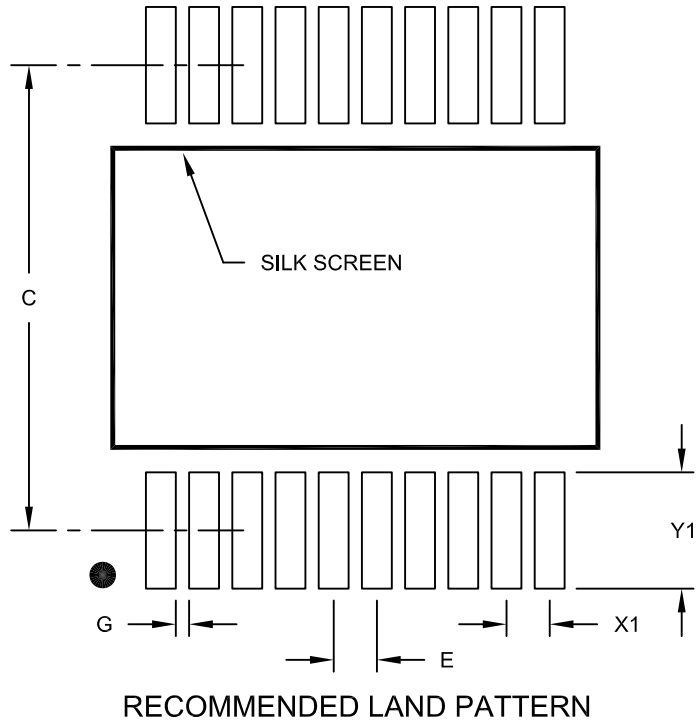

Dimension Limits		MILLIMETERS		
		MIN	NOM	MAX
Contact Pitch	E	0.65 BSC		
Contact Pad Spacing	C		7.20	
Contact Pad Width (X20)	X1			0.45
Contact Pad Length (X20)	Y1			1.75
Distance Between Pads	G	0.20		

Notes:

1. Dimensioning and tolerancing per ASME Y14.5M

BSC: Basic Dimension. Theoretically exact value shown without tolerances.

Microchip Technology Drawing No. C04-2072A

PIC16LF1554/1559

20-Lead Plastic Quad Flat, No Lead Package (ML) – 4x4x0.9 mm Body [QFN]

Note: For the most current package drawings, please see the Microchip Packaging Specification located at <http://www.microchip.com/packaging>

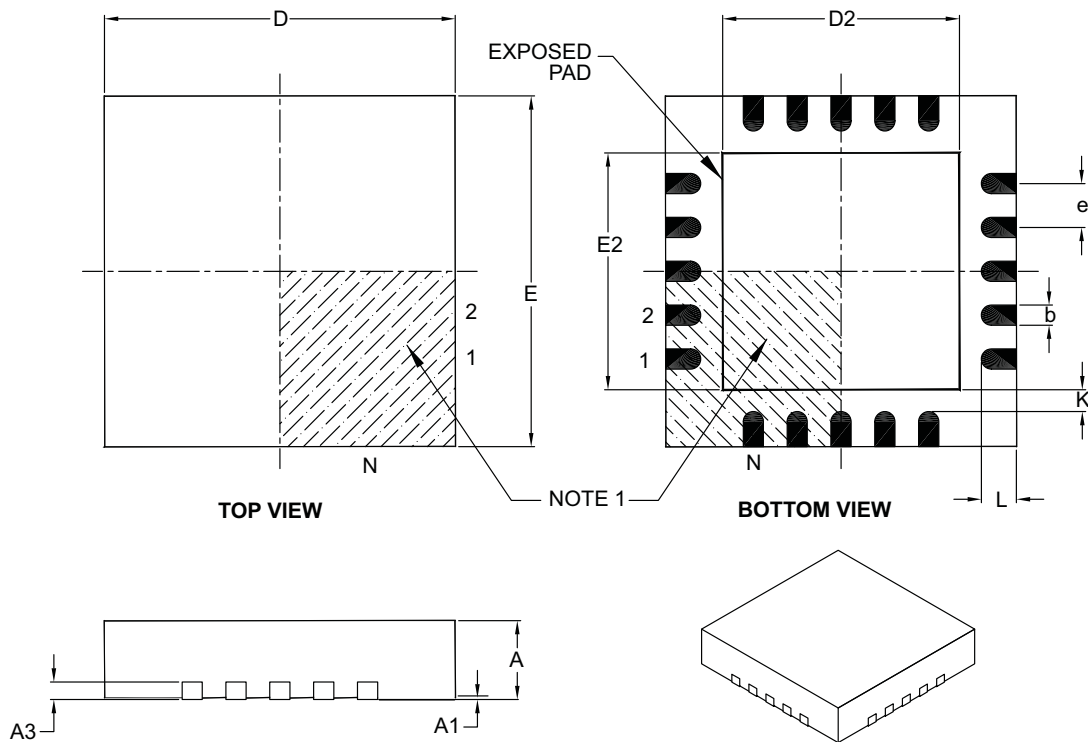

Dimension Limits	Units	MILLIMETERS		
		MIN	NOM	MAX
Number of Pins	N	20		
Pitch	e	0.50 BSC		
Overall Height	A	0.80	0.90	1.00
Standoff	A1	0.00	0.02	0.05
Contact Thickness	A3	0.20 REF		
Overall Width	E	4.00 BSC		
Exposed Pad Width	E2	2.60	2.70	2.80
Overall Length	D	4.00 BSC		
Exposed Pad Length	D2	2.60	2.70	2.80
Contact Width	b	0.18	0.25	0.30
Contact Length	L	0.30	0.40	0.50
Contact-to-Exposed Pad	K	0.20	-	-

Notes:

- Pin 1 visual index feature may vary, but must be located within the hatched area.
- Package is saw singulated.
- Dimensioning and tolerancing per ASME Y14.5M.

BSC: Basic Dimension. Theoretically exact value shown without tolerances.

REF: Reference Dimension, usually without tolerance, for information purposes only.

Microchip Technology Drawing C04-126B

PIC16LF1554/1559

20-Lead Plastic Quad Flat, No Lead Package (ML) - 4x4 mm Body [QFN]
With 0.40 mm Contact Length

Note: For the most current package drawings, please see the Microchip Packaging Specification located at <http://www.microchip.com/packaging>

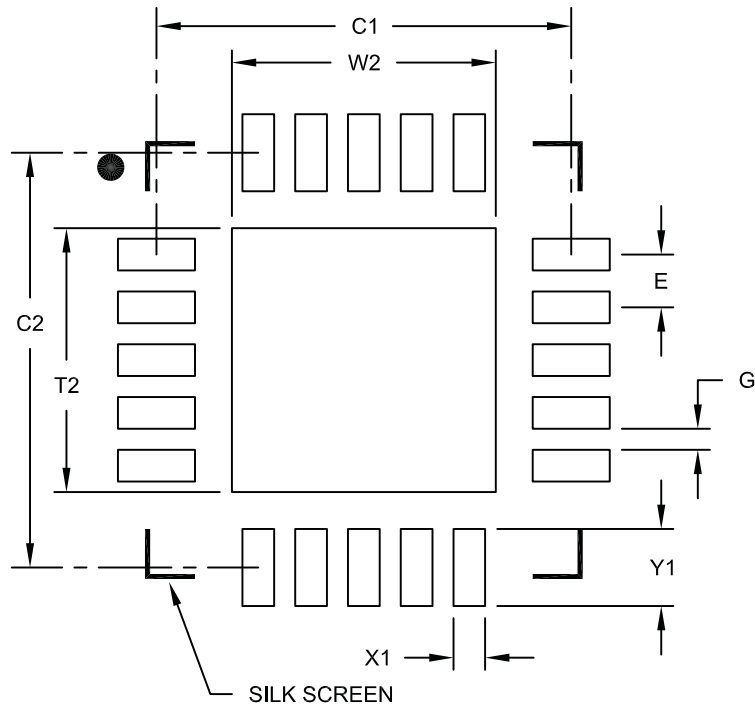

RECOMMENDED LAND PATTERN

Dimension Limits	Units	MILLIMETERS		
		MIN	NOM	MAX
Contact Pitch	E	0.50 BSC		
Optional Center Pad Width	W2			2.50
Optional Center Pad Length	T2			2.50
Contact Pad Spacing	C1		3.93	
Contact Pad Spacing	C2		3.93	
Contact Pad Width	X1			0.30
Contact Pad Length	Y1			0.73
Distance Between Pads	G	0.20		

Notes:

1. Dimensioning and tolerancing per ASME Y14.5M

BSC: Basic Dimension. Theoretically exact value shown without tolerances.

Microchip Technology Drawing No. C04-2126A

PIC16LF1554/1559

APPENDIX A: DATA SHEET REVISION HISTORY

Revision A (07/2014)

Initial release of the document.

THE MICROCHIP WEB SITE

Microchip provides online support via our WWW site at www.microchip.com. This web site is used as a means to make files and information easily available to customers. Accessible by using your favorite Internet browser, the web site contains the following information:

- **Product Support** – Data sheets and errata, application notes and sample programs, design resources, user's guides and hardware support documents, latest software releases and archived software
- **General Technical Support** – Frequently Asked Questions (FAQ), technical support requests, online discussion groups, Microchip consultant program member listing
- **Business of Microchip** – Product selector and ordering guides, latest Microchip press releases, listing of seminars and events, listings of Microchip sales offices, distributors and factory representatives

CUSTOMER CHANGE NOTIFICATION SERVICE

Microchip's customer notification service helps keep customers current on Microchip products. Subscribers will receive e-mail notification whenever there are changes, updates, revisions or errata related to a specified product family or development tool of interest.

To register, access the Microchip web site at www.microchip.com. Under "Support", click on "Customer Change Notification" and follow the registration instructions.

CUSTOMER SUPPORT

Users of Microchip products can receive assistance through several channels:

- Distributor or Representative
- Local Sales Office
- Field Application Engineer (FAE)
- Technical Support

Customers should contact their distributor, representative or Field Application Engineer (FAE) for support. Local sales offices are also available to help customers. A listing of sales offices and locations is included in the back of this document.

Technical support is available through the web site at: <http://microchip.com/support>

PIC16LF1554/1559

PRODUCT IDENTIFICATION SYSTEM

To order or obtain information, e.g., on pricing or delivery, refer to the factory or the listed sales office.

<u>PART NO.</u>	<u>[X]⁽¹⁾</u>	<u>/XX</u>	<u>XXX</u>
Device	Tape and Reel Option	Package	Pattern
Device:	PIC16LF1554, PIC16LF1559.		
Tape and Reel Option:	Blank = Standard packaging (tube or tray) T = Tape and Reel ⁽¹⁾		
Package:⁽²⁾	P = Plastic DIP SL = SOIC ST = TSSOP ML = QFN SS = SSOP		
Pattern:	QTP, SQTP, Code or Special Requirements (blank otherwise)		

Examples:

- a) PIC16LF1559T/SS
Tape and Reel,
SOIC package
- b) PIC16LF1554/P
PDIP package
- c) PIC16LF1559/ML 298
QFN package

Note 1: Tape and Reel identifier only appears in the catalog part number description. This identifier is used for ordering purposes and is not printed on the device package. Check with your Microchip Sales Office for package availability with the Tape and Reel option.

2: For other small form-factor package availability and marking information, please visit www.microchip.com/packaging or contact your local sales office.

Note the following details of the code protection feature on Microchip devices:

- Microchip products meet the specification contained in their particular Microchip Data Sheet.
- Microchip believes that its family of products is one of the most secure families of its kind on the market today, when used in the intended manner and under normal conditions.
- There are dishonest and possibly illegal methods used to breach the code protection feature. All of these methods, to our knowledge, require using the Microchip products in a manner outside the operating specifications contained in Microchip's Data Sheets. Most likely, the person doing so is engaged in theft of intellectual property.
- Microchip is willing to work with the customer who is concerned about the integrity of their code.
- Neither Microchip nor any other semiconductor manufacturer can guarantee the security of their code. Code protection does not mean that we are guaranteeing the product as “unbreakable.”

Code protection is constantly evolving. We at Microchip are committed to continuously improving the code protection features of our products. Attempts to break Microchip's code protection feature may be a violation of the Digital Millennium Copyright Act. If such acts allow unauthorized access to your software or other copyrighted work, you may have a right to sue for relief under that Act.

Information contained in this publication regarding device applications and the like is provided only for your convenience and may be superseded by updates. It is your responsibility to ensure that your application meets with your specifications. MICROCHIP MAKES NO REPRESENTATIONS OR WARRANTIES OF ANY KIND WHETHER EXPRESS OR IMPLIED, WRITTEN OR ORAL, STATUTORY OR OTHERWISE, RELATED TO THE INFORMATION, INCLUDING BUT NOT LIMITED TO ITS CONDITION, QUALITY, PERFORMANCE, MERCHANTABILITY OR FITNESS FOR PURPOSE. Microchip disclaims all liability arising from this information and its use. Use of Microchip devices in life support and/or safety applications is entirely at the buyer's risk, and the buyer agrees to defend, indemnify and hold harmless Microchip from any and all damages, claims, suits, or expenses resulting from such use. No licenses are conveyed, implicitly or otherwise, under any Microchip intellectual property rights.

Trademarks

The Microchip name and logo, the Microchip logo, dsPIC, FlashFlex, flexPWR, JukeBlox, KEELOQ, KEELOQ logo, Klear, LANCheck, MediaLB, MOST, MOST logo, MPLAB, OptoLyzer, PIC, PICSTART, PIC³² logo, RightTouch, SpyNIC, SST, SST Logo, SuperFlash and UNI/O are registered trademarks of Microchip Technology Incorporated in the U.S.A. and other countries.

The Embedded Control Solutions Company and mTouch are registered trademarks of Microchip Technology Incorporated in the U.S.A.

Analog-for-the-Digital Age, BodyCom, chipKIT, chipKIT logo, CodeGuard, dsPICDEM, dsPICDEM.net, ECAN, In-Circuit Serial Programming, ICSP, Inter-Chip Connectivity, KlearNet, KlearNet logo, MiWi, MPASM, MPF, MPLAB Certified logo, MPLIB, MPLINK, MultiTRAK, NetDetach, Omniscient Code Generation, PICDEM, PICDEM.net, PICkit, PICtail, RightTouch logo, REAL ICE, SQI, Serial Quad I/O, Total Endurance, TSHARC, USBCheck, VariSense, ViewSpan, WiperLock, Wireless DNA, and ZENA are trademarks of Microchip Technology Incorporated in the U.S.A. and other countries.

SQTP is a service mark of Microchip Technology Incorporated in the U.S.A.

Silicon Storage Technology is a registered trademark of Microchip Technology Inc. in other countries.

GestIC is a registered trademarks of Microchip Technology Germany II GmbH & Co. KG, a subsidiary of Microchip Technology Inc., in other countries.

All other trademarks mentioned herein are property of their respective companies.

© 2014, Microchip Technology Incorporated, Printed in the U.S.A., All Rights Reserved.

ISBN: 978-1-63276-372-3

QUALITY MANAGEMENT SYSTEM
CERTIFIED BY DNV
== ISO/TS 16949 ==

Microchip received ISO/TS-16949:2009 certification for its worldwide headquarters, design and wafer fabrication facilities in Chandler and Tempe, Arizona; Gresham, Oregon and design centers in California and India. The Company's quality system processes and procedures are for its PIC[®] MCUs and dsPIC[®] DSCs, KEELOQ[®] code hopping devices, Serial EEPROMs, microperipherals, nonvolatile memory and analog products. In addition, Microchip's quality system for the design and manufacture of development systems is ISO 9001:2000 certified.



MICROCHIP

Worldwide Sales and Service

AMERICAS

Corporate Office
2355 West Chandler Blvd.
Chandler, AZ 85224-6199
Tel: 480-792-7200
Fax: 480-792-7277
Technical Support:
<http://www.microchip.com/support>
Web Address:
www.microchip.com

Atlanta
Duluth, GA
Tel: 678-957-9614
Fax: 678-957-1455

Austin, TX
Tel: 512-257-3370

Boston
Westborough, MA
Tel: 774-760-0087
Fax: 774-760-0088

Chicago
Itasca, IL
Tel: 630-285-0071
Fax: 630-285-0075

Cleveland
Independence, OH
Tel: 216-447-0464
Fax: 216-447-0643

Dallas
Addison, TX
Tel: 972-818-7423
Fax: 972-818-2924

Detroit
Novi, MI
Tel: 248-848-4000

Houston, TX
Tel: 281-894-5983

Indianapolis
Noblesville, IN
Tel: 317-773-8323
Fax: 317-773-5453

Los Angeles
Mission Viejo, CA
Tel: 949-462-9523
Fax: 949-462-9608

New York, NY
Tel: 631-435-6000

San Jose, CA
Tel: 408-735-9110

Canada - Toronto
Tel: 905-673-0699
Fax: 905-673-6509

ASIA/PACIFIC

Asia Pacific Office
Suites 3707-14, 37th Floor
Tower 6, The Gateway
Harbour City, Kowloon
Hong Kong
Tel: 852-2943-5100
Fax: 852-2401-3431

Australia - Sydney
Tel: 61-2-9868-6733
Fax: 61-2-9868-6755

China - Beijing
Tel: 86-10-8569-7000
Fax: 86-10-8528-2104

China - Chengdu
Tel: 86-28-8665-5511
Fax: 86-28-8665-7889

China - Chongqing
Tel: 86-23-8980-9588
Fax: 86-23-8980-9500

China - Hangzhou
Tel: 86-571-8792-8115
Fax: 86-571-8792-8116

China - Hong Kong SAR
Tel: 852-2943-5100
Fax: 852-2401-3431

China - Nanjing
Tel: 86-25-8473-2460
Fax: 86-25-8473-2470

China - Qingdao
Tel: 86-532-8502-7355
Fax: 86-532-8502-7205

China - Shanghai
Tel: 86-21-5407-5533
Fax: 86-21-5407-5066

China - Shenyang
Tel: 86-24-2334-2829
Fax: 86-24-2334-2393

China - Shenzhen
Tel: 86-755-8864-2200
Fax: 86-755-8203-1760

China - Wuhan
Tel: 86-27-5980-5300
Fax: 86-27-5980-5118

China - Xian
Tel: 86-29-8833-7252
Fax: 86-29-8833-7256

China - Xiamen
Tel: 86-592-2388138
Fax: 86-592-2388130

China - Zhuhai
Tel: 86-756-3210040
Fax: 86-756-3210049

ASIA/PACIFIC

India - Bangalore
Tel: 91-80-3090-4444
Fax: 91-80-3090-4123

India - New Delhi
Tel: 91-11-4160-8631
Fax: 91-11-4160-8632

India - Pune
Tel: 91-20-3019-1500

Japan - Osaka
Tel: 81-6-6152-7160
Fax: 81-6-6152-9310

Japan - Tokyo
Tel: 81-3-6880-3770
Fax: 81-3-6880-3771

Korea - Daegu
Tel: 82-53-744-4301
Fax: 82-53-744-4302

Korea - Seoul
Tel: 82-2-554-7200
Fax: 82-2-558-5932 or
82-2-558-5934

Malaysia - Kuala Lumpur
Tel: 60-3-6201-9857
Fax: 60-3-6201-9859

Malaysia - Penang
Tel: 60-4-227-8870
Fax: 60-4-227-4068

Philippines - Manila
Tel: 63-2-634-9065
Fax: 63-2-634-9069

Singapore
Tel: 65-6334-8870
Fax: 65-6334-8850

Taiwan - Hsin Chu
Tel: 886-3-5778-366
Fax: 886-3-5770-955

Taiwan - Kaohsiung
Tel: 886-7-213-7830

Taiwan - Taipei
Tel: 886-2-2508-8600
Fax: 886-2-2508-0102

Thailand - Bangkok
Tel: 66-2-694-1351
Fax: 66-2-694-1350

EUROPE

Austria - Wels
Tel: 43-7242-2244-39
Fax: 43-7242-2244-393

Denmark - Copenhagen
Tel: 45-4450-2828
Fax: 45-4485-2829

France - Paris
Tel: 33-1-69-53-63-20
Fax: 33-1-69-30-90-79

Germany - Dusseldorf
Tel: 49-2129-3766400

Germany - Munich
Tel: 49-89-627-144-0
Fax: 49-89-627-144-44

Germany - Pforzheim
Tel: 49-7231-424750

Italy - Milan
Tel: 39-0331-742611
Fax: 39-0331-466781

Italy - Venice
Tel: 39-049-7625286

Netherlands - Drunen
Tel: 31-416-690399
Fax: 31-416-690340

Poland - Warsaw
Tel: 48-22-3325737

Spain - Madrid
Tel: 34-91-708-08-90
Fax: 34-91-708-08-91

Sweden - Stockholm
Tel: 46-8-5090-4654

UK - Wokingham
Tel: 44-118-921-5800
Fax: 44-118-921-5820

03/25/14

Mouser Electronics

Authorized Distributor

Click to View Pricing, Inventory, Delivery & Lifecycle Information:

Microchip:

[PIC16LF1554-E/ML](#) [PIC16LF1554T-I/SL](#) [PIC16LF1559-I/P](#) [PIC16LF1554-E/SL](#) [PIC16LF1554-E/P](#) [PIC16LF1559-I/SS](#) [PIC16LF1559T-I/SS](#) [PIC16LF1554T-I/ML](#) [PIC16LF1559-E/ML](#) [PIC16LF1559-E/SS](#) [PIC16LF1554-I/P](#) [PIC16LF1559-E/P](#) [PIC16LF1554-E/ST](#) [PIC16LF1554-I/ST](#) [PIC16LF1559-I/ML](#) [PIC16LF1554-I/ML](#) [PIC16LF1554T-I/ST](#) [PIC16LF1559T-I/ML](#) [PIC16LF1554-I/SL](#)